

Ytelseserklæring nr.: DOP_IK_ETA-17-0262_v4_NO

1. Produkt:

Schöck Isokorb® med ståltrykkelementer

2. Bruksområde:

Bærende varmeisolerende forbindelseelement til tilkobling til armerte plater av stålbetong.

3. Produsent:

Schöck Bauteile GmbH, Schöckstraße 1, D-76534 Baden-Baden

4. System(er) til vurdering og verifisering av ytelsesbestandighet:

System 1+

5. Teknisk vurdering:

Europeisk vurderingsdokument / harmonisert standard / nasjonal standard:

EAD 050001-00-0301, utstedt februar 2018

Europeisk teknisk vurdering / godkjenning:

ETA-17/0262, utstedt den 20.01.2021

Teknisk vurderingsorgan / godkjenningsinstitutt:

Deutsches Institut für Bautechnik (DIBt), Kolonnenstr. 30B, D-10829 Berlin

Teknisk kontrollorgan / eksternt kontrollorgan:

Versuchsanstalt für Stahl, Holz und Stein, Universität Karlsruhe (TH), 76128 Karlsruhe: NB 0769

6. Erklært(e) ytelse(r):

Hovedkjenne-tegn	Ytelse
Bæreevne	
f_{yd}	Se vedlegg C1: tabell C.1
$N_{ki,d}$	Se vedlegg C1: tabell C.2
Byggematerialenes brannegenskaper	
Klasse iht. EN 13501-1	Se vedlegg A5
Betongstål	Klasse A1
Rustfritt stål	Klasse A1
Mildt stål	Klasse A1
Isolasjonsfuge	Klasse E
Brannvernmaterialer	Klasse A1
I tilfelle brann oppskummende materialer	Klasse E
Plastskinner	NPD
Brannmotstand	
Brannmotstandstid (bæreevne R)	Se vedlegg C2, C3: tabell C.3, tabell C.4 Utførelse iht. figur 32 til 34
Trinnlydsdemping	
NPD	
Termisk motstand	
$R_{eq,TI}$	Se vedlegg C5 og C6: tabell C.6

7. Eget teknisk dokumentasjon og/eller spesifikk teknisk dokumentasjon:

Teknisk dokumentasjon til europeisk vurdering av Schöck Isokorb® med ståltrykkelementer – foreligger hos DIBt.

Ytelsen til det foreliggende produktet samsvarer med de(n) erklærte ytelsen(e). Det er utelukkende den ovenfornevnte produsenten som har ansvaret for oppretting av ytelseserklæringen iht. forordning (EU) nr. 305/2011. Undertegnet for produsenten og i produsentens navn av:

Baden-Baden, 01.07.2021

(Sted, dato)



(Dr.ing. Niklas Puttendörfer, Head of R&D)

Approval body for construction products
and types of construction

Bautechnisches Prüfamt

An institution established by the Federal and
Laender Governments



European Technical Assessment

ETA-17/0262
of 20 January 2021

English translation prepared by DIBt - Original version in German language

General Part

Technical Assessment Body issuing the
European Technical Assessment:

Deutsches Institut für Bautechnik

Trade name of the construction product

Schöck Isokorb® with steel compression elements

Product family
to which the construction product belongs

Load bearing thermal insulating elements which form a
thermal break between balconies and internal floors

Manufacturer

Schöck Bauteile GmbH
Vimbucher Straße 2
76534 Baden-Baden
DEUTSCHLAND

Manufacturing plant

Schöck Bauteile GmbH, Vimbucher Straße 2
76534 Baden-Baden, Germany

Schöck Bauteile GmbH, Nordsternstraße 61
45329 Essen, Germany

Schöck Bauteile Ges.m.b.H., Handwerkstraße 2
4055 Pucking, Austria

Schöck Sp. z o.o., ul. Przejazdowa 99
43-100 Tychy, Poland

This European Technical Assessment
contains

40 pages including 4 annexes which form an integral part
of this assessment

This European Technical Assessment is
issued in accordance with Regulation (EU)
No 305/2011, on the basis of

EAD 050001-00-0301

This version replaces

ETA-17/0262 issued on 20 February 2019

The European Technical Assessment is issued by the Technical Assessment Body in its official language. Translations of this European Technical Assessment in other languages shall fully correspond to the original issued document and shall be identified as such.

Communication of this European Technical Assessment, including transmission by electronic means, shall be in full. However, partial reproduction may only be made with the written consent of the issuing Technical Assessment Body. Any partial reproduction shall be identified as such.

This European Technical Assessment may be withdrawn by the issuing Technical Assessment Body, in particular pursuant to information by the Commission in accordance with Article 25(3) of Regulation (EU) No 305/2011.

Specific Part

1 Technical description of the product

The Schöck Isokorb® with steel compression elements is used as load-bearing thermal insulation element to connect reinforced concrete slabs under static or quasi-static load.

The product description is given in Annex A.

The characteristic material values, dimensions and tolerances of the Schöck Isokorb® with steel compression elements not indicated in Annexes A1 to A5 shall correspond to the respective values laid down in the technical documentation^[1] of this European technical assessment.

2 Specification of the intended use in accordance with the applicable European Assessment Document

The performances given in Section 3 are only valid if the Schöck Isokorb® with steel compression elements is used in compliance with the specifications and conditions given in Annex B.

The verifications and assessment methods on which this European Technical Assessment is based lead to the assumption of a working life of the Schöck Isokorb® with steel compression elements of at least 50 years. The indications given on the working life cannot be interpreted as a guarantee given by the producer, but are to be regarded only as a means for choosing the right products in relation to the expected economically reasonable working life of the works.

3 Performance of the product and references to the methods used for its assessment

3.1 Mechanical resistance and stability (BWR 1)

Essential characteristic	Performance
Load bearing capacity	See Annex C1

3.2 Safety in case of fire (BWR 2)

Essential characteristic	Performance
Reaction to fire of materials	See Annex A5
Resistance to fire	See Annex C2 – C3

3.3 Protection against noise (BWR 5)

Essential characteristic	Performance
Impact sound insulation	No performance assessed

3.4 Energy economy and heat retention (BWR 6)

Essential characteristic	Performance
Thermal resistance	See Annex C5 – C6

[1] The technical documentation of this European technical assessment is deposited at the Deutsches Institut für Bautechnik and, as far as relevant for the tasks of the approved bodies involved in the attestation of conformity procedure, is handed over to the approved bodies.

English translation prepared by DIBt

4 Assessment and verification of constancy of performance (AVCP) system applied, with reference to its legal base

In accordance with EAD No. 050001-00-0301, the applicable European legal act is: [1997/0597/EC].

The systems to be applied is: 1+

5 Technical details necessary for the implementation of the AVCP system, as provided for in the applicable EAD

Technical details necessary for the implementation of the AVCP system are laid down in the control plan deposited with Deutsches Institut für Bautechnik.

The following standards are referred to in this European Technical Assessment:

- EN 206:2013+A1:2016 Concrete: Specification, performance, production and conformity
- EN 1992-1-1:2004 + AC:2010 Eurocode 2: Design of concrete structures – Part 1-1: General design rules and rules for buildings
- EN 1993-1-1:2005 + AC:2009 Eurocode 3: Design of steel structures – Part 1-1: General design rules and rules for buildings
- EN 1993-1-4:2006 + A1:2015 Eurocode 3: Design of steel structures – Part 1-4: General rules – Supplementary rules for stainless
- EN 10088-1:2014 Stainless steels – Part 1: List of stainless steels
- EN 12664:2001 Thermal performance of building materials and products – Determination of thermal resistance by means of guarded hot plate and heat flow meter methods – Dry and moist products of medium and low thermal resistance
- EN 13163:2012+A2:2016 Thermal insulation products for buildings – Factory made expanded polystyrene (EPS) products – Specification
- EN 13245-1:2010 Plastics – Unplasticized poly(vinyl chloride) (PVC-U) profiles for building applications – Part 1: Designation of PVC-U profiles
- EN 13245-2:2008 + AC:2009 Plastics – Unplasticized poly(vinyl chloride) (PVC-U) profiles for building applications – Part 2: PVC-U profiles and PVC-UE profiles for internal and external wall and ceiling finishes
- EN 13501-1:2018 Fire classification of construction products and building elements – Part 1: Classification using data from reaction to fire tests
- EN ISO 6946:2017 Building components and building elements – Thermal resistance and thermal transmittance – Calculation method (ISO 6946:2017)

English translation prepared by DIBt

- EN ISO 10211:2017 Thermal bridges in building construction – Heat flows and surface temperatures – Detailed calculations (ISO 10211:2017)
- EN ISO 10456:2007+AC:2009 Building materials and products – Hygrothermal properties – Tabulated design values and procedures for determining declared and design thermal values (ISO 10456:2007 + Cor. 1:2009)
- EN ISO 17660-1:2006 Welding – Welding of reinforcing steel – Part 1: Load-bearing welded joints (ISO 17660-1:2006)

Issued in Berlin on 20 January 2021 by Deutsches Institut für Bautechnik

Dipl.-Ing. Beatrix Wittstock
Head of Section

beglaubigt:
Kisan

A.1 Type overview

- type K, type K-F (variation in several parts), type K-ID, type O:

Tension and compression elements to transfer bending moments as well as tilted bars passing through the insulation layer to transfer shear forces

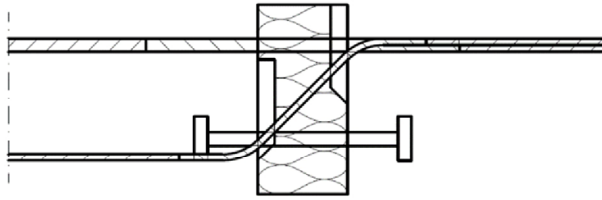

Fig. 1: Schöck Isokorb® type K

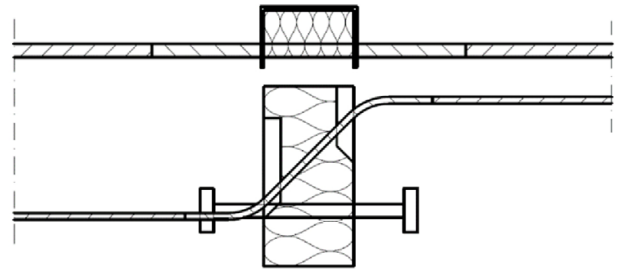

Fig. 2: Schöck Isokorb® type K-F
(Variation in several parts)

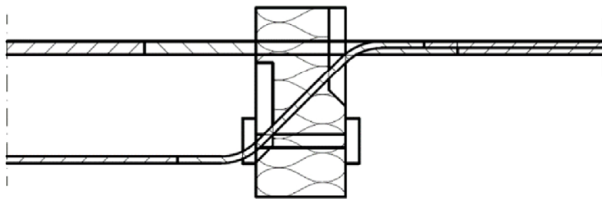

Fig. 3: Schöck Isokorb® type K
(flush compression plates)

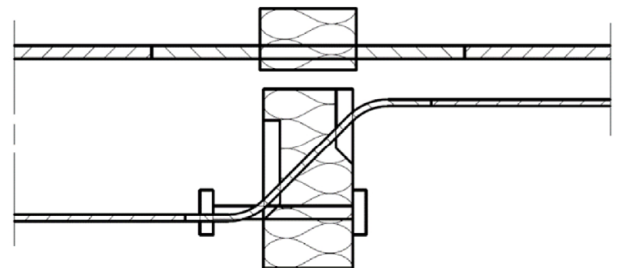

Fig. 4: Schöck Isokorb® type K-ID or RT type K
(ceiling side flush compression plates)

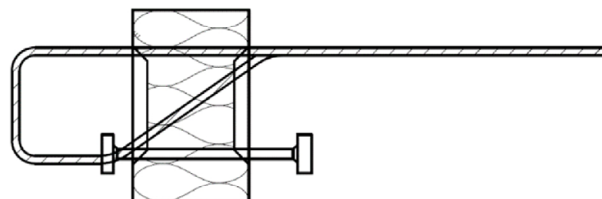

Fig. 5: Schöck Isokorb® type O

Design variants of the compression elements (SCE): steel compression bearing with a welded compression plate, compression bar

Schöck Isokorb® with steel compression elements

Product description
Type overview

Annex A1

- **type Q:** tilted bars and compression elements in the insulation layer, exclusively to transfer shear forces

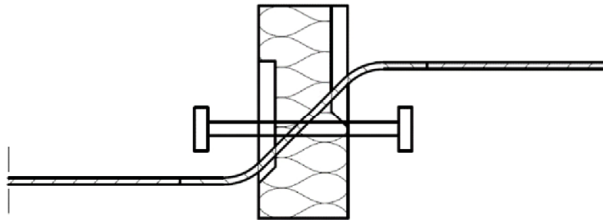

Fig. 6: Schöck Isokorb® type Q

- **type D, type A, type F:** tensile and compression bars to transfer positive and negative bending moments as well as tilted bars passing through the insulation layer to transfer positive and negative shear forces

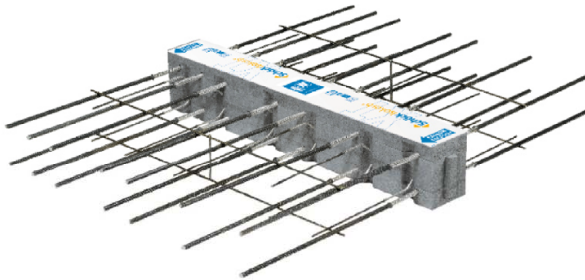

Fig. 7: Schöck Isokorb® type D

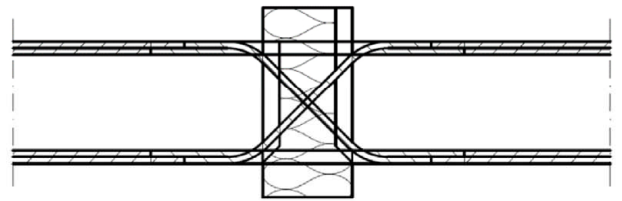

Fig. 8: Schöck Isokorb® type D

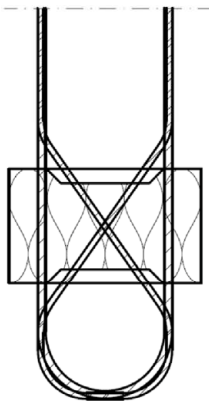

Fig. 9: Schöck Isokorb® type A

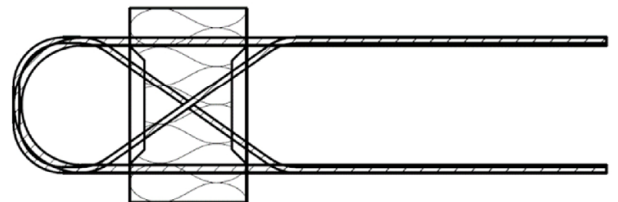

Fig. 10: Schöck Isokorb® type F

Design variants of the compression elements (SCE): steel compression bearing with a welded compression plate, compression bar

Schöck Isokorb® with steel compression elements

Product description
Type overview

Annex A2

A.2 Dimensions and positioning of the bars and compression elements in the area of the insulation joint

In the insulation joint (60 mm to 120 mm) and along a length of at least 100 mm within the adjacent concrete components, the tensile, shear force and compression bars consist of stainless reinforcing steel or stainless steel bars, to the end of which reinforcing steel is welded. Steel compression bearings with welded-on compression plates made of structural steel consist of stainless steel or stainless steel bars along a length of at least 50 mm within the adjacent concrete components. Steel compression bearings with welded-on compression plates made of stainless steel consist of stainless steel or stainless steel bars designed flush with the insulation joint.

Tension reinforcement:

- Diameter: $\varnothing \leq 20 \text{ mm}$
Graduated nominal diameter in combination with Annex A4
When $\varnothing > 16 \text{ mm}$,
component thickness $h \geq 240 \text{ mm}$
- Number per metre: $n \geq 4/m$
- Axial distance of the bars $\leq 300 \text{ mm}$, on average $\leq 250 \text{ mm}$

Steel compression elements (SCE):

- Diameter : $\varnothing \leq 20 \text{ mm}$
- Number per metre: $n \geq 4/m$
- Axial distance of the bars: $\leq 300 \text{ mm}$, on average $\leq 250 \text{ mm}$
- Modulus of elasticity $\geq 160000 \text{ N/mm}^2$
(shall be verified via an inspection certificate 3.1 in accordance with EN 10204)
- Two design variants:
 - Compression forces are transmitted either via the bond of the reinforcing steel
 - Or via a compression plate in case this bar is not used to transmit tensile forces methodically
 - Compression plate consists of structural steel or stainless steel
 - The compression plate is connected by welding in a force-fit manner with the compression bars on the bearing side of the connecting elements

Shear force reinforcement:

- Diameter: $\varnothing \leq 14 \text{ mm}$
- Tilt of the shear bars in the insulation layer: Usually $\alpha=45^\circ$ for an insulation thickness of 60 mm and 80 mm, $\alpha = 35^\circ$ for an insulation thickness of 120 mm
- Axial distance of the bars: $(\varnothing < 8 \text{ mm}) \leq 600 \text{ mm}$, on average $\leq 500 \text{ mm}$
 $(\varnothing \geq 8 \text{ mm}) \leq 300 \text{ mm}$, on average $\leq 250 \text{ mm}$
- Number per metre: $(\varnothing < 8 \text{ mm}) n \geq 2/m$
 $(\varnothing \geq 8 \text{ mm}) n \geq 4/m$
- In the concrete-free area: Bars should not have any bends
- Bends start point: $\geq 2 \cdot \varnothing$ inside the concrete,

Schöck Isokorb® with steel compression elements

Product description
Dimensions

Annex A3

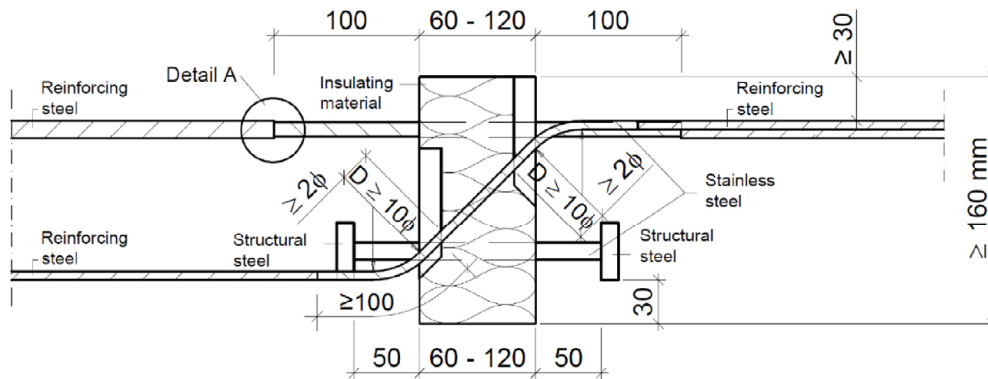

Fig. 11: Schöck Isokorb® type K with SCE

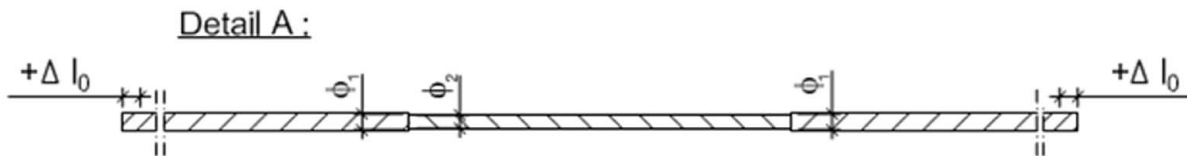

Fig. 12: tension bar (type K) with diameter combination

Table A.1: Diameter combinations and additions for overlap length

Graduated tensile bars $\varnothing_1 - \varnothing_2 - \varnothing_1$	Reinforcing steel	Stainless steel	Δl_0 (mm)
	\varnothing_1 (mm) $R_{p0,2}$ (N/mm ²)	\varnothing_2 (mm) $R_{p0,2}$ (N/mm ²)	
8 - 6,5 - 8	8 500	6,5 800	20
8 - 7 - 8	8 500	7 700	13
10 - 8 - 10	10 500	8 700 / (820 optional)	20
12 - 9,5 - 12	12 500	9,5 820	20
12 - 10 - 12	12 500	10 700	17
12 - 11 - 12	12 500	11 700	9
14 - 12 - 14	14 500	12 700	14

Material specification: see Section A.3

Schöck Isokorb® with steel compression elements

Product description
Dimensions

Annex A4

A.3 Materials

The following materials shall be used:

Reinforcing steel:	B500B, class A1 as per EN 13501-1
Stainless steel:	B500 NR or stainless steel round bars (S255, S460, S690) with corrosion resistance class III in accordance with EN 1993-1-4, class A1 as per EN 13501-1
Structural steel:	S235JR, S235J0, S235J2, S355JR, S355J2 or S355J0 as per EN 10025-2, for the compression plates, class A1 as per EN 13501-1
Insulating material:	Rigid polystyrene foam (EPS) as per EN 13163, class E as per EN 13501-1
Fire protection plate:	Moisture repellent, weather-resistant and UV-resistant panels, class A1 as per EN 13501-1
Material expanding in case of fire:	Halogen free, three-dimensional foaming up building material on a graphite base with a minimum foaming factor of 14, class E as per EN 13501-1
Plastic channels:	PVC-U as per EN 13245-1 and EN 13245-2, performance as per EN 13501-1 is not determined

Schöck Isokorb® with steel compression elements

Product description
Material

Annex A5

B.1 Intended use

- Static or quasi-static action combination
- Minimum strength class of the reinforced components to be connected made of normal-strength concrete according to EN 206: C20/25, for external components C25/30
- For the connection of 16 cm to 50 cm thick reinforced concrete slabs and cantilevers as well as vertical constructions, like parapets

B.1.1 Design

EN 1992-1-1 in connection with EN 1993-1-1 and the provisions in accordance with Annex D shall apply to design.

- The connected slab shall be divided by joints (arranged in accordance with section B.2.1)
- Structural verification of the further transmission of the transferred forces shall be provided
- The deviations from the strain of a structurally identical slab without an insulation joint are limited to the joint area and the connecting edges through compliance with the provisions of this European technical assessment
- The undistributed strain may then be assumed to exist at a distance h from the joint edge
- Variable moments and shear forces along a connected edge shall be taken into account in the structural analysis
- Strain on the slab connections due to local twisting moments (torques) shall be excluded
- Small normal forces due to imposed deformation in the girder bars (at the end of the line supports, e.g. beside free edges or expansion joints) shall be neglected in the calculation, normal constraining forces in the direction of the bars of the slab connections shall be excluded (see Annex B2 for example)
- Connected components: ratio height/width $\leq 1/3$, if no special verification is performed for the transfer of the transverse tensile stresses

B.2 Installation requirements

B.2.1 Centre and joint distances

- Tensile and compression members, shear force bars (the provisions according to section D.1.2.3):

$$5 \text{ cm} \leq s_1 \leq \frac{1}{2} s_{2,\text{max}}$$

where:

- s_1 centre distance from the free edge or the expansion joint
- $s_{2,\text{max}}$ permissible maximum distance of the bars from each other

- External reinforced concrete components: expansion joints shall be placed in a right angle to the insulation layer (see Annex B2)
- Joint distance: Table B.1

Schöck Isokorb® with steel compression elements

Intended use
Installation requirements

Annex B1

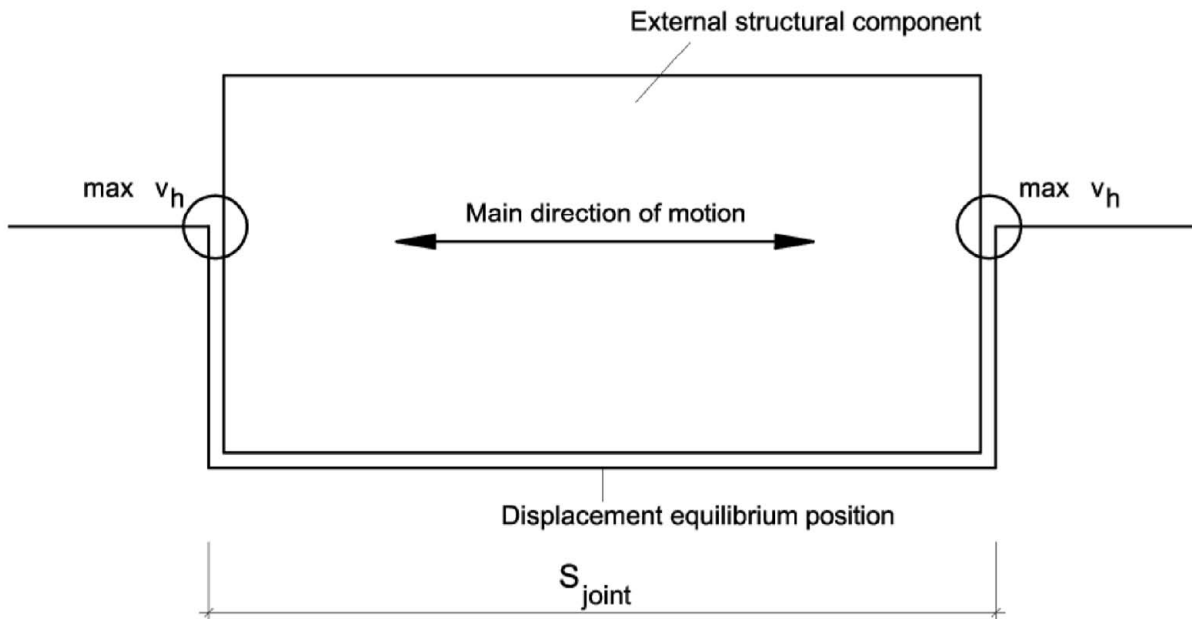

Fig. 13: Installation situation with support on opposite edges

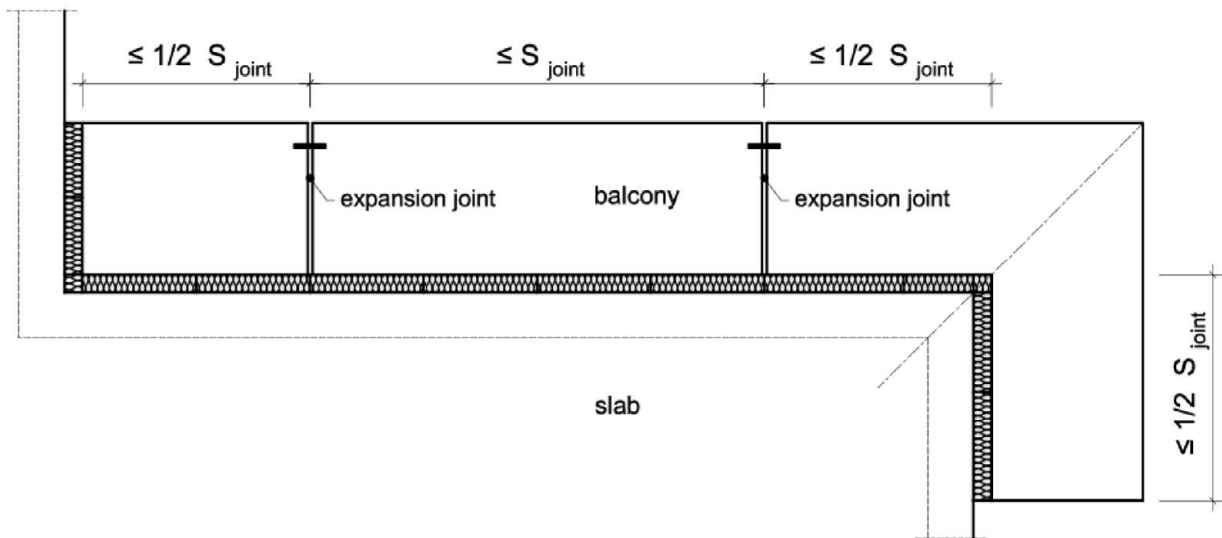

Fig. 14: Installation situation with expansion joint

Schöck Isokorb® with steel compression elements

Intended use

Installation Determination

Representation of insulation situation, Insulation thickness 60 – 120 mm

Annex B2

Table B.1: Permissible joint distances in [m]

Thickness of the insulation joint [mm]	Bar diameter in the joint [mm]						
	≤9,5	10	11	12	14	16	20
60	8,1	7,8	7,3	6,9	6,3	5,6	5,1
80	13,5	13,0	12,2	11,7	10,1	9,2	8,0
120	23,0	21,7	20,6	19,8	17,0	15,5	13,5

B.2.2 Structural design

The minimum concrete cover in accordance with EN 1992-1-1 shall be observed. This applies to tensile bars, shear reinforcement or existing installation reinforcement.

The reinforcement of the concrete structures connected to the load bearing thermal insulation elements shall be extended to the insulation layer in consideration of the required concrete cover in accordance with EN 1992-1-1.

The transverse bars of the upper connection reinforcement shall generally lie on the outside on the longitudinal bars of the slab connections. In the case of bars with a nominal diameter $\varnothing < 16$ mm an exception may be made if the following conditions are respected:

- The installation of the shear force bars directly underneath the longitudinal bars of the slab connection is possible
- The installation is monitored, e.g. by the construction engineer
- The necessary installation steps shall be described in the installation manual (see Annex B4)

The front surface of the components to be connected shall receive edge reinforcement in accordance with EN 1992-1-1, section 9.3.1.4. Edge reinforcement e.g. in the form of stirrups with at least $\varnothing \geq 6$ mm, $s \leq 25$ cm and 2 longitudinal bars each with $\varnothing \geq 8$ mm shall be positioned on the front surface of the connected slabs parallel to the insulation joint. Inclusion of lattice girders with a maximum distance of 100 mm from the insulation joint in accordance with Annex B12 shall be permitted.

Edge reinforcement on the component sides running parallel to the load-bearing thermal insulation elements should be installed as follows:

- Moments and shear forces are transferred:
 - o Shall overlap the tensile bars
- Uplift shear forces respectively uplift moments can also be transferred:
 - o Shall overlap the tensile and compression bars
- Exclusively shear forces are transferred:
 - o The required tensile reinforcement shall not be graded in the area of the load-bearing thermal insulation element
 - o The tensile reinforcement shall be anchored in the compression zone on the frontal side with hooks
 - o Alternatively: stirrups at every shear force bar

Subsequent bending of the bars of the load-bearing thermal insulation element is not permissible.

Schöck Isokorb® with steel compression elements

Intended use
Installation requirements

Annex B3

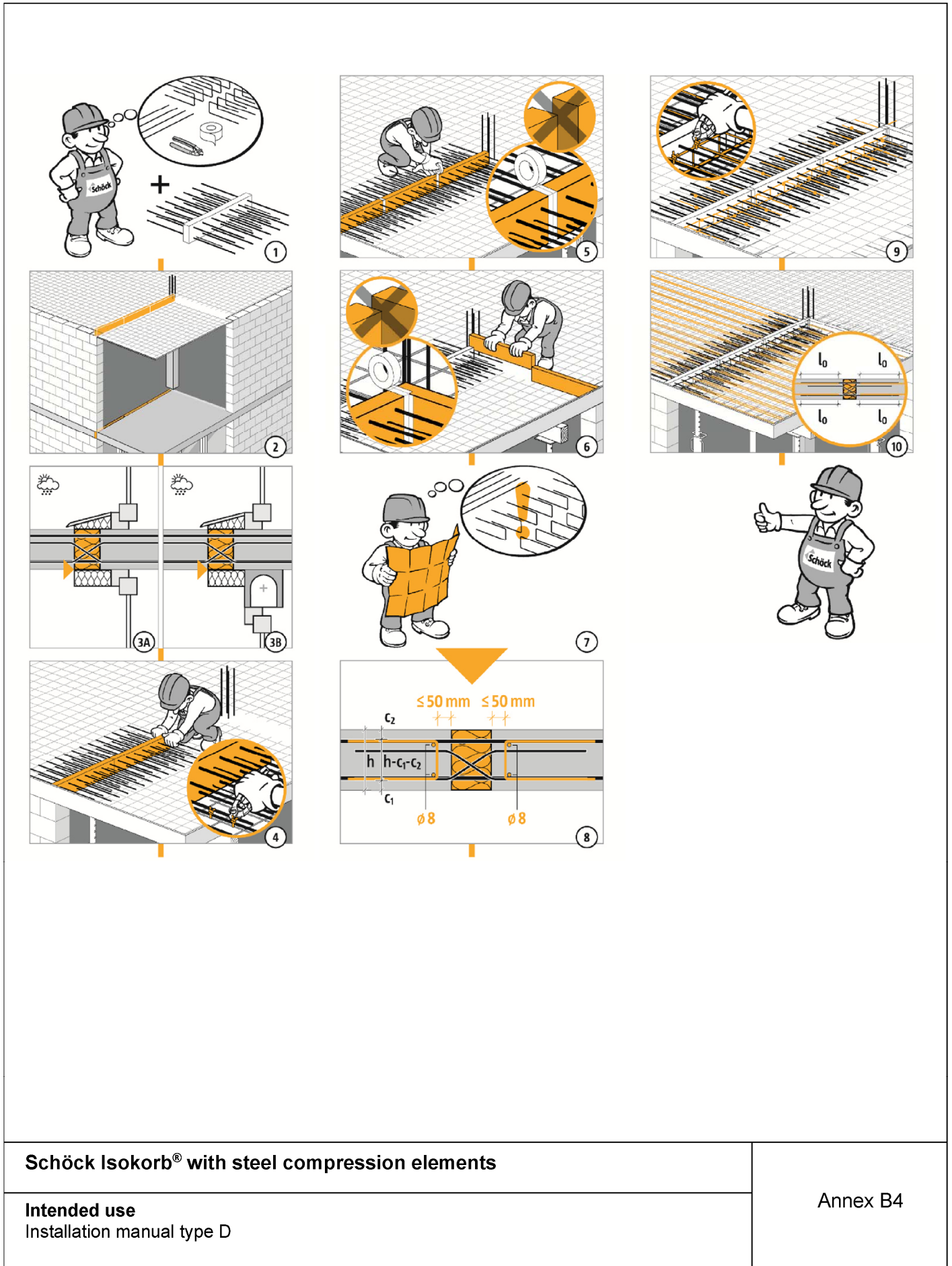

Schöck Isokorb® type K and type K-F

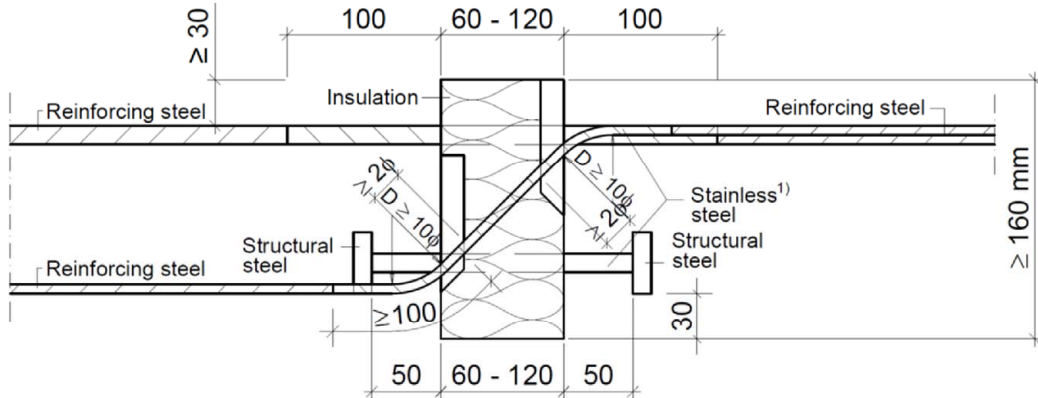

Fig. 15: Schöck Isokorb® type K with SCE

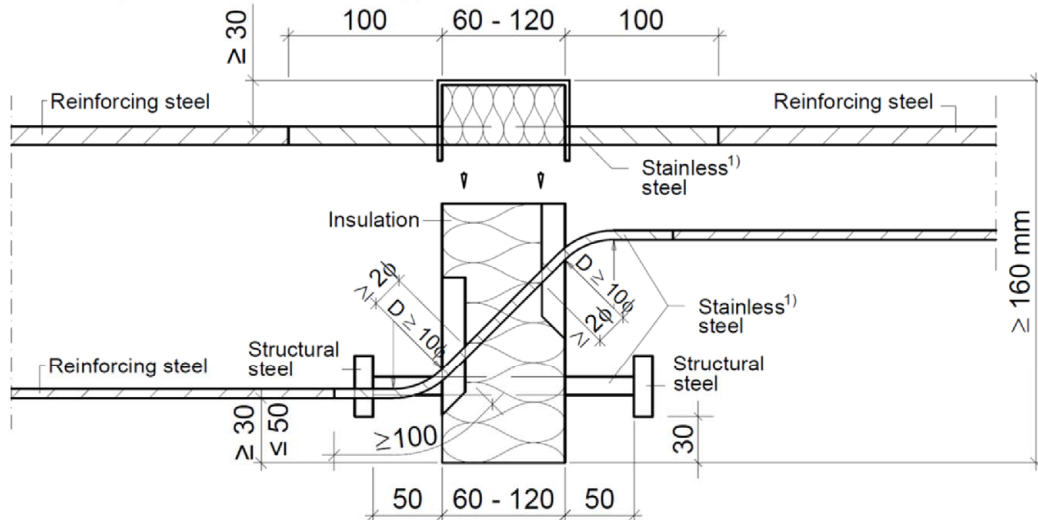

Fig. 16: Schöck Isokorb® type K-F (version segmented) with SCE

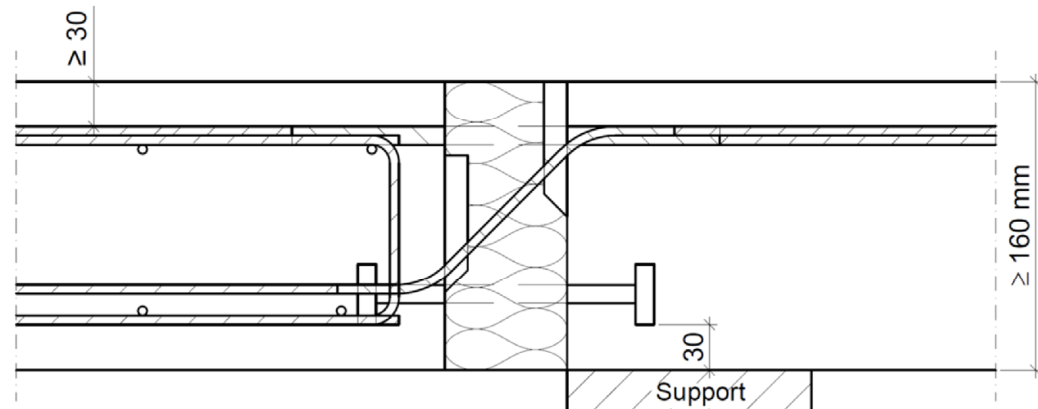

Fig. 17: Example of a Schöck Isokorb® type K with SCE with on-site reinforcement

Material specification: see Section A.3

Schöck Isokorb® with steel compression elements

Intended use

Installation Determination
Type K and type K-F with SCE; Insulation thickness 60 - 120 mm

Annex B5

Schöck Isokorb® type O

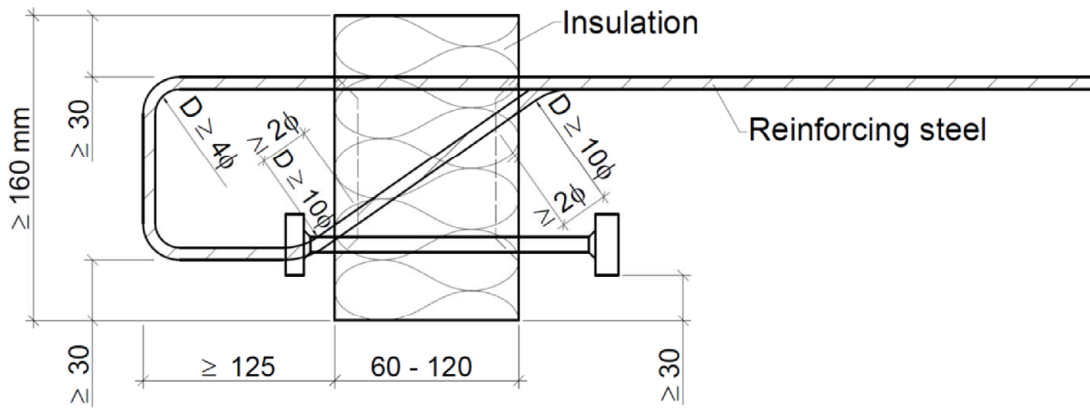

Fig. 18: Schöck Isokorb® type O with SCE

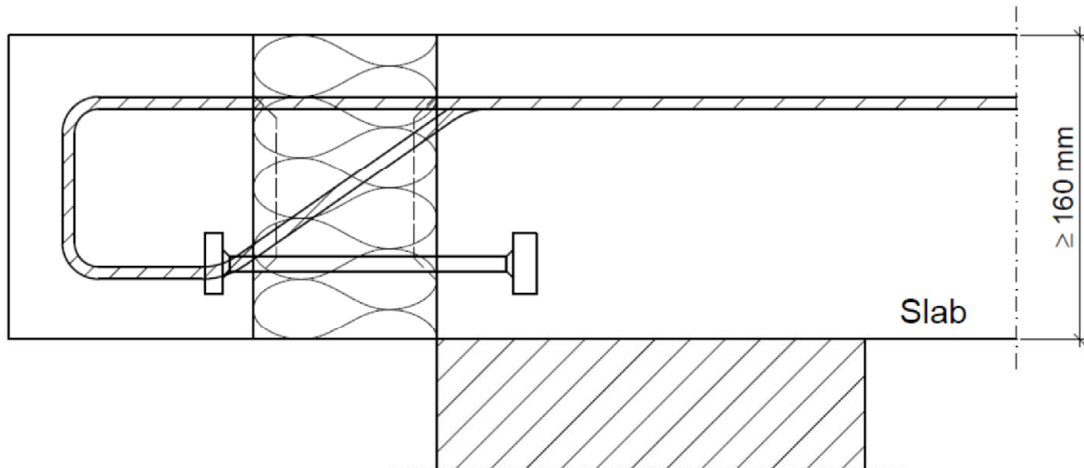

Fig. 19: Example of a Schöck Isokorb® type O with SCE

Material specification: see Section A.3

Schöck Isokorb® with steel compression elements

Intended use

Installation Determination
Type O with SCE, Insulation thickness 60 - 120 mm

Annex B6

Schöck Isokorb® type Q

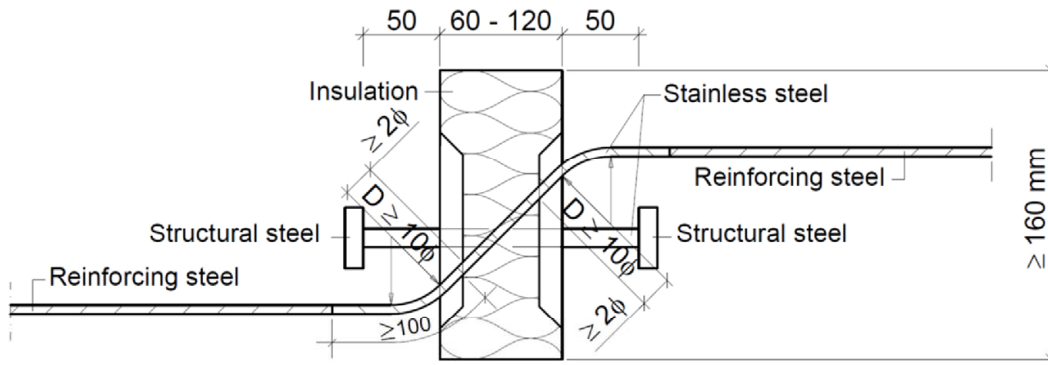

Fig. 20: Schöck Isokorb® type Q with SCE

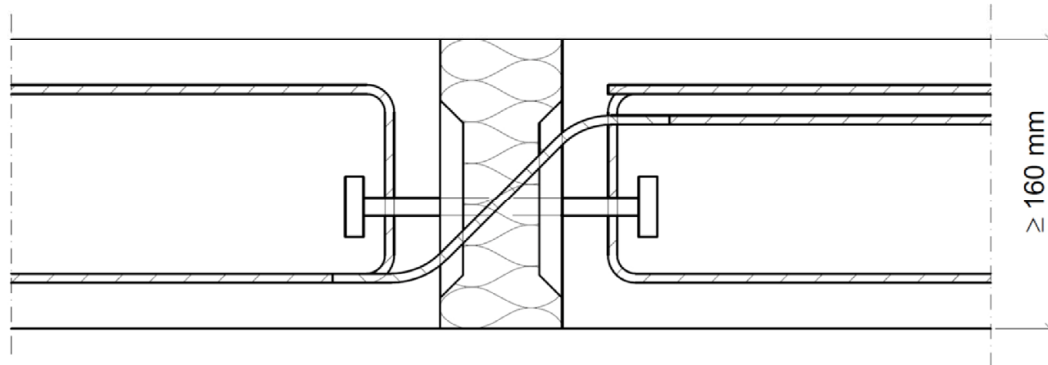

Fig. 21: Example of a Schöck Isokorb® type Q with SCE with on-site reinforcement

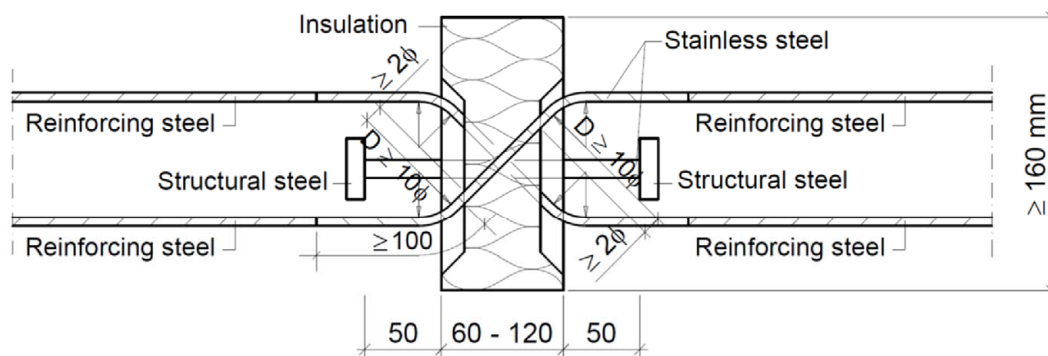

Fig. 22: Schöck Isokorb® type Q-VV with SCE

Material specification: see Section A.3

Schöck Isokorb® with steel compression elements

Intended use
Installation Determination
Type Q with SCE, Insulation thickness 60 - 120 mm

Annex B7

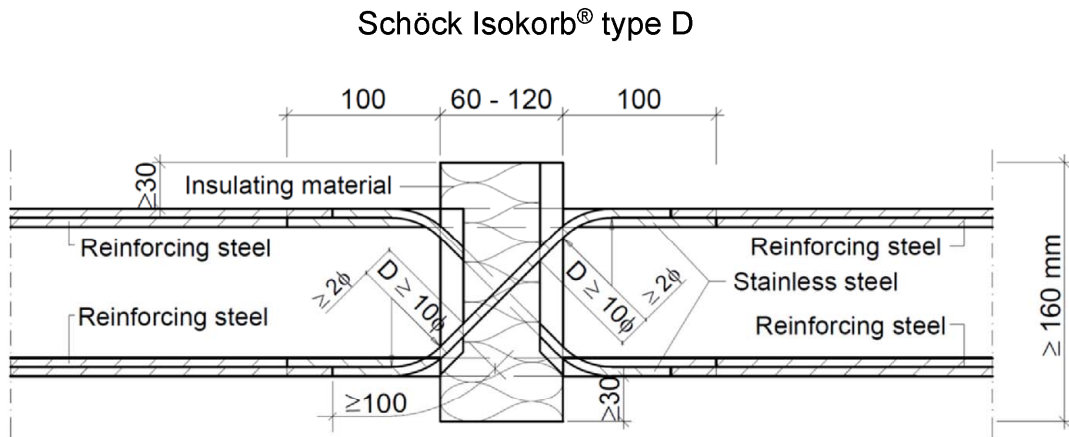

Fig. 23: Schöck Isokorb® type D with SCE

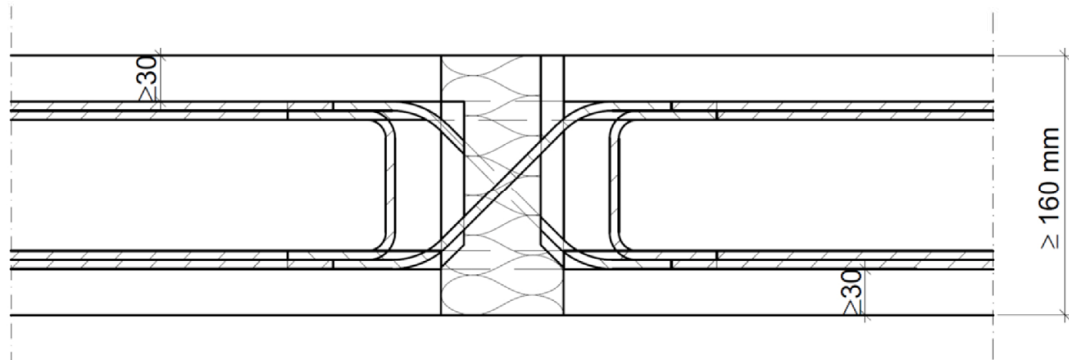

Fig. 24: Example of a Schöck Isokorb® type D with SCE with on-site reinforcement

Material specification: see Section A.3

Schöck Isokorb® with steel compression elements

Intended use

Installation Determination
Type D with SCE, Insulation thickness 60 - 120 mm

Annex B8

Schöck Isokorb® type A

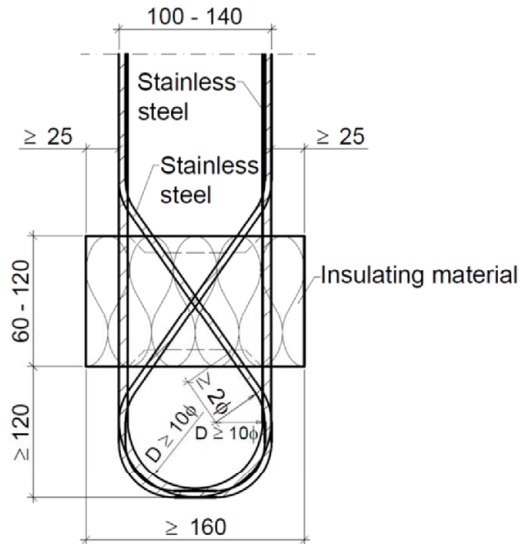

Fig. 25: Schöck Isokorb® type A with SCE

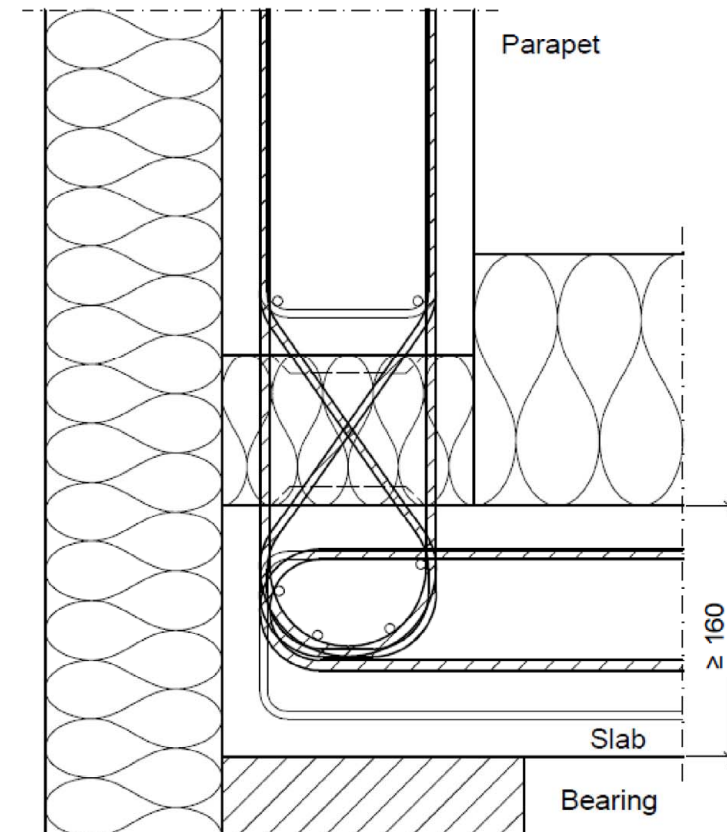

Fig. 26: Example of a Schöck Isokorb® type A with SCE with on-site reinforcement

Material specification: see Section A.3

Schöck Isokorb® with steel compression elements

Intended use

Installation Determination
Type A with SCE, Insulation thickness 60 - 120 mm

Annex B9

Schöck Isokorb® type F

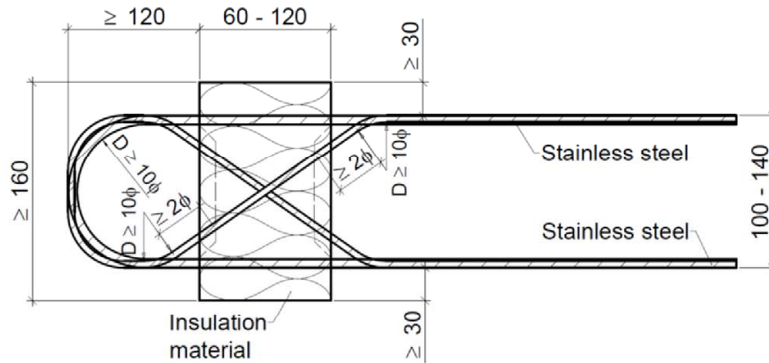

Fig. 27: Schöck Isokorb® type F with SCE

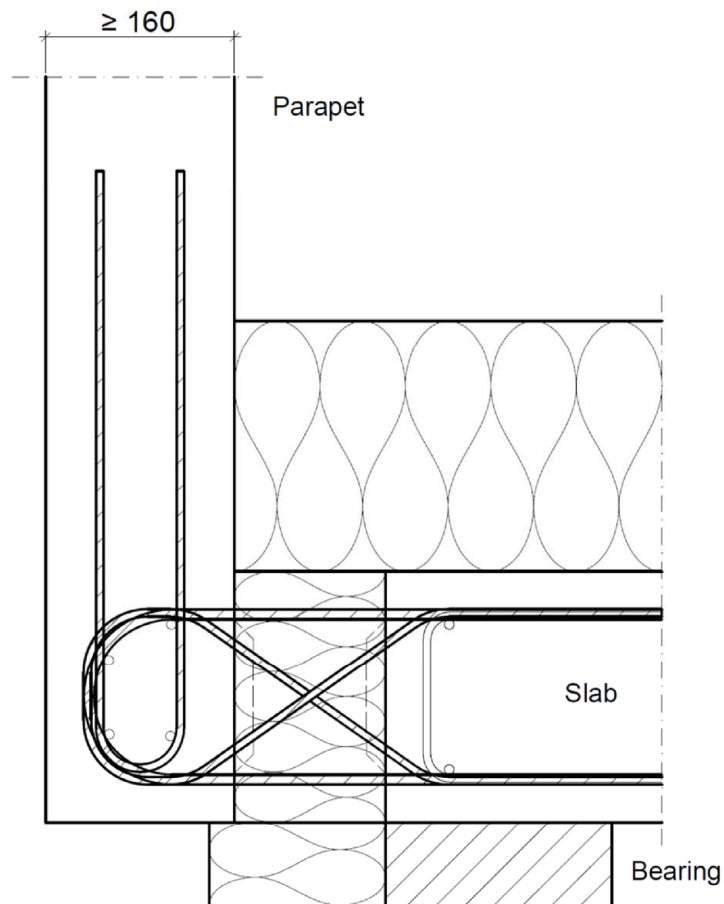

Fig. 28: Example of a Schöck Isokorb® type F with SCE with on-site reinforcement

Material specification: see Section A.3

Schöck Isokorb® with steel compression elements

Intended use

Installation Determination
Type F with SCE, Insulation thickness 60 - 120 mm

Annex B10

If the slabs connected to the load-bearing thermal insulation elements are implemented as prefabricated concrete slabs (Annex B12), the following conditions should be respected:

In situ concrete topping in accordance with Annex B12 with a width of at least 10 cm shall be carried out between the load bearing thermal insulation element and the prefabricated concrete slab

The concrete composition of the in-situ concrete topping (maximum aggregate size d_g) shall be matched with this distance.

B.2.3 Notes on use with fire protection requirements

When using the elements to connect reinforced concrete components (slabs) that are subject to fire protection requirements, the provisions of section C.2 shall be observed.

Schöck Isokorb® with steel compression elements	Annex B11
Intended use Installation requirements	

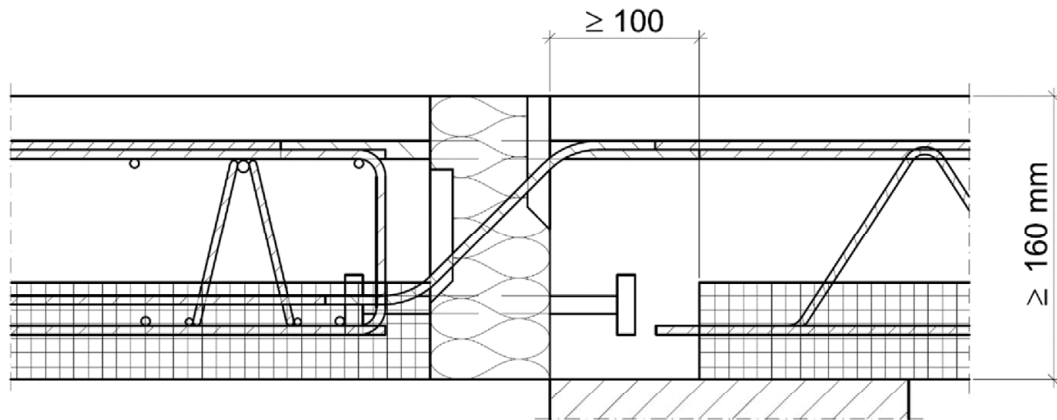

Fig. 29: Example of a Schöck Isokorb® type K and type K-F (Version segmented) with prefabricated concrete slabs

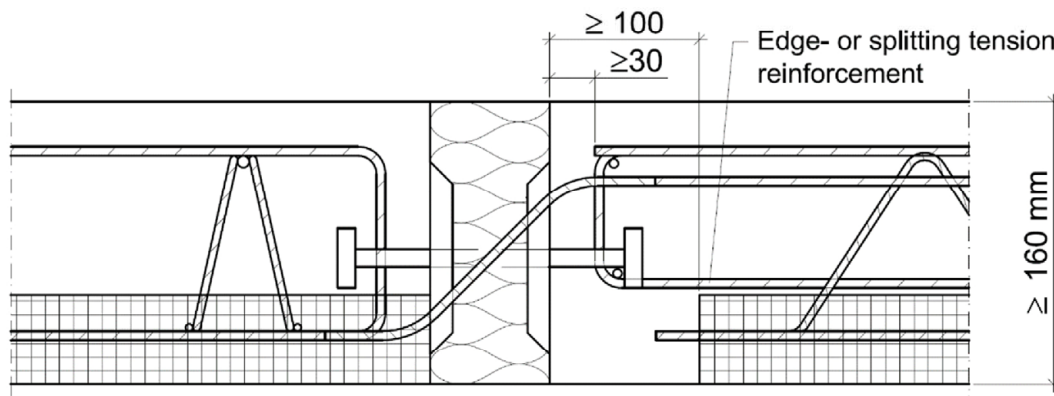

Fig. 30: Example of a Schöck Isokorb® type Q with prefabricated concrete slabs

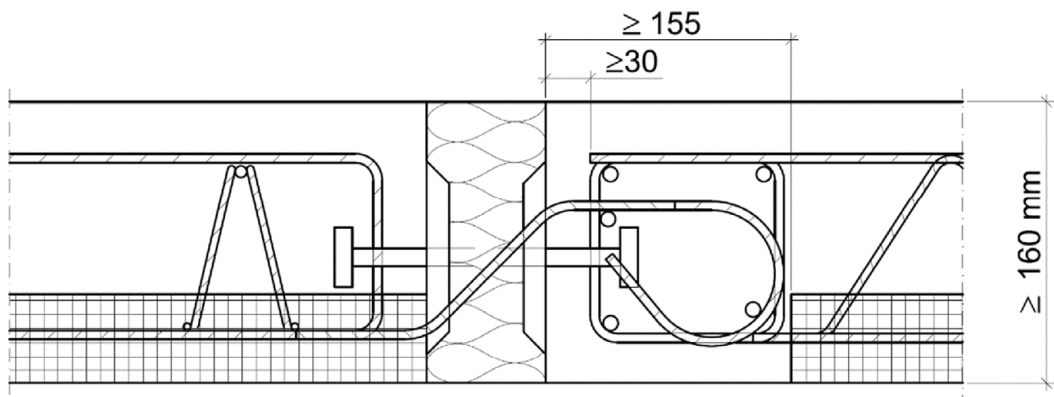

Fig. 31: Example of a Schöck Isokorb® type Q with prefabricated concrete slabs

Schöck Isokorb® with steel compression elements

Intended use

Service condition

Installation situation for prefabricated concrete slabs, Insulation thickness 60 - 120 mm

Annex B12

C.1 Load bearing capacity

Table C.1: Design values of the yield strengths for tension loads for the bars used

bar consisting of	f_{yd} in N/mm ²
B500B NR	435
stainless steel round bar S355	323
stainless steel round bar S460	418
stainless steel round bar S690	627
B500 NR $R_{p0,2}$ 700	609 (for tension bars)
B500 NR $R_{p0,2}$ 800	661 (for tension bars)
B500 NR $R_{p0,2}$ 820	678 (for tension bars)

Table C.2: Design values of compression forces for stainless steels

Diameter	Insulation thickness	System length	$N_{ki,d}$ B500 NR $R_{p0,2}$ 700	$N_{ki,d}$ S460	$N_{ki,d}$ S690	$N_{ki,d}$ B500B NR
[mm]	[mm]	[mm]	[kN]	[kN]	[kN]	[kN]
6	60	72	11,0	-	-	-
	80	92	10,7	-	-	-
	120	132	8,2	-	-	-
8	60	76	21,3	-	-	-
	80	96	21,7	-	-	-
	120	136	17,8	-	-	-
10	60	80	35,0	27,4	-	-
	80	100	36,3	26,0	-	-
	120	140	31,5	23,3	-	-
12	60	84	52,1	40,5	-	-
	80	104	53,6	38,8	-	-
	120	144	49,5	35,4	-	-
14	80	108	-	54,1	70,7	53,4
	120	148	-	50,1	64,4	49,2
16	80	112	-	72,1	-	-
	120	152	-	67,4	-	-
20	80	120	-	115,7	152,4	-
	120	160	-	110,0	143,0	-

Schöck Isokorb® with steel compression elements

Performance parameters
Design values of tension and compression bars (SCE)

Annex C1

C.2 Fire resistance

C.2.1 Performance features regarding load-bearing capacity in case of fire

If the performance characteristics specified in Annex C1 for verification according to the intended use under normal temperatures are met, the load bearing capacity of connections with Schöck Isokorb® is also guaranteed in case of fire for the fire resistance period indicated in Table C.4. This applies to a reduction coefficient η_f according to EN 1992-1-2, section 2.4.2 to $\eta_f = 0.7$, for designs according to Fig. 32 to Fig. 34 and subject to the following boundary conditions.

- The connection joint provided with the Schöck Isokorb® is completely covered with fire protection plates in accordance with Annex A5 on the top and bottom side respectively (see Annex C3).
- The fire protection plates in the area of planned tensile loads shall be realised either with a lateral overhang on the side of 10 mm opposite the insulation body (see Annex C3, Fig. 32 to Fig. 34) or with additional intumescent seals on both lateral surfaces (see Annex C4).
- The required thickness t of the fire protection plates, the minimum axis spacing u and v and the minimum concrete cover of the steel reinforcement shall be taken from Table C.3.

Table C.3: Classification, minimum of c and u and required fire protection plate thickness t in [mm]

min c [mm]	30
min u [mm]	35
min t [mm]	10

Table C.4: Fire resistance duration (load bearing capacity)

Design variant in accordance with	Fire resistance period (load bearing capacity) in minutes
Fig. 32	120
Fig. 33	120
Fig. 34	120

Schöck Isokorb® with steel compression elements

Performance parameters
Load bearing capacity in case of fire

Annex C2

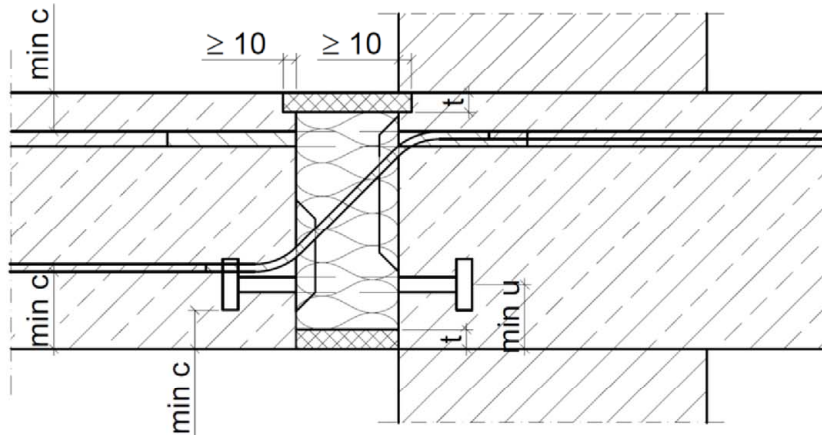

Fig. 32: Schöck Isokorb® type K and type K-F (analog type O) with SCE

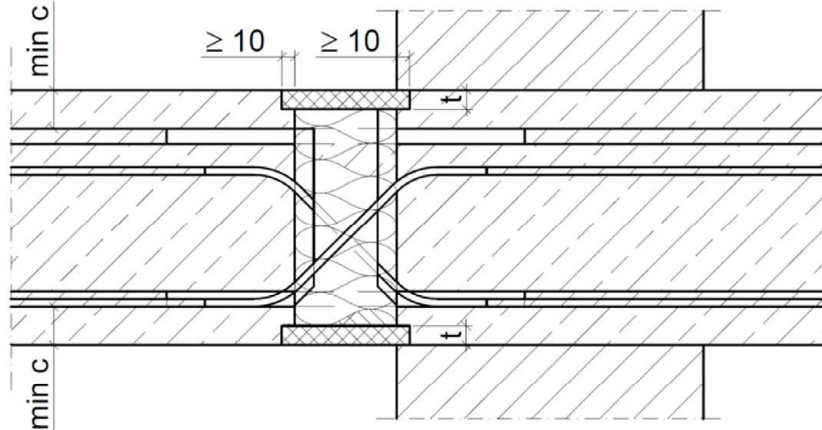

Fig. 33: Schöck Isokorb® type D (analog type A and type F) with SCE

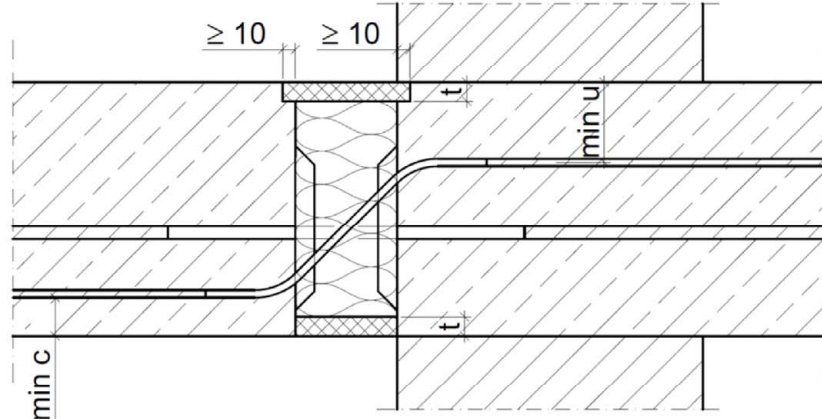

Fig. 34: Schöck Isokorb® type Q with SCE

As per section C.2, executing with intumescent insulation on both sides rather than a lateral overhang of 10 mm is also possible.

As per section C.2, the lateral projection of 10 mm is not necessary if the fire protection panels are not located in the range of planned tensile loads.

Material specification: see Section A.3

Schöck Isokorb® with steel compression elements

Performance parameters

Load bearing capacity in case of fire

Annex C3

C.2.2 Resistance to fire of building elements (informative)

Floor or roof structures as well as balcony and walkways connected to reinforced concrete components with Schöck Isokorb® as per the intended use can be classified as specified in Table C.5 in terms of fire resistance in accordance with EN 13501-2, see Annex C3. The following boundary conditions must be observed:

- The load-bearing capacity in case of fire has been declared for the Schöck Isokorb®.
- See Annex C2, bullet 1 to 3 and Table C.3.
- Connections of the remaining edges of floor or roof structures, which are not connected with the Schöck Isokorb® to adjacent or supporting components, shall be verified in accordance with the provisions of the Member States for the corresponding fire resistance.

Table C.5: Component classification

Design variant	Floor or roof construction with fire separating function	Balcony and walkway, parapets
Fig. 32	REI 120	R 120
Fig. 33	REI 120	R 120
Fig. 34	REI 120	R 120

Schöck Isokorb® with steel compression elements

Classification of building element (informative)
Fire resistance

Annex C4

C.3 Thermal resistance

The equivalent thermal resistance $R_{eq, TI}$ of Schöck Isokorb® is determined according to EN ISO 6946 and EN ISO 10211 by using finite element method and a detailed 3D model of the thermal insulation element for the configuration shown in Fig. 35:

$$R_{cal} = R_{eq, TI} + R_{con}$$

$$R_{eq, TI} = R_{cal} - R_{con} = R_{cal} - \frac{0,06 \text{ m}}{2,3 \text{ W / (m} \cdot \text{K)}}$$

$$\lambda_{eq, TI} = \frac{d_{n, TI}}{R_{eq, TI}}$$

Where

- R_{cal} calculated thermal resistance for configuration shown in Fig. 35
- $R_{eq, TI}$ equivalent thermal resistance of thermal insulation element
- R_{con} thermal resistance of concrete block
- $d_{n, TI}$ nominal thickness of thermal insulation element
- $\lambda_{eq, TI}$ equivalent thermal conductivity of thermal insulation element

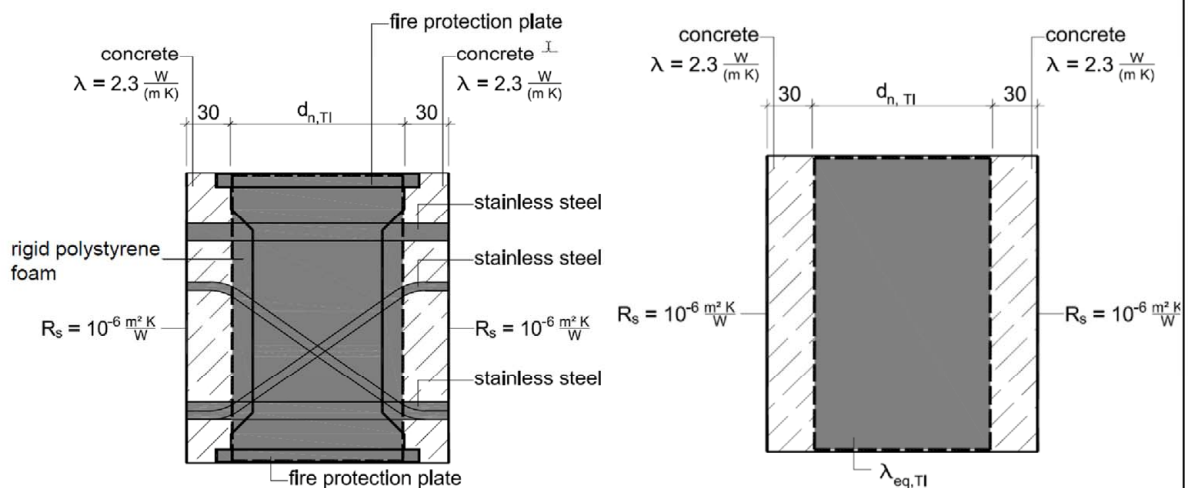

Fig. 35: cross section of configuration to calculate the equivalent thermal resistance $R_{eq, TI}$ and simplified analogous model with $\lambda_{eq, TI}$

The design thermal conductivities of the components are given in Table C.6.

Schöck Isokorb® with steel compression elements	Annex C5
Performance parameters Thermal resistance	

Table C.6: Used materials and their design thermal conductivity

Material	Design thermal conductivity λ [W/(m*K)]	Source of data
Rigid polystyrene foam (EPS)	0.031	Determined according to EN ISO 13163 and EN ISO 10456
Stainless steel	13 - 15	According to EN 10088-1
PE-HD	0.5	According to EN ISO 10456
PVC-U	0.17	According to EN ISO 10456
Fire protection plate	According to technical documentation	Determined according to EN 12664 and EN ISO 10456

Schöck Isokorb® with steel compression elements

Performance parameters
Thermal resistance

Annex C6

D.1 Structural Analysis

D.1.1 General

- EN 1992-1-1 and EN 1993-1-1 shall apply to design and structural analysis (in the joint)
- Structural verification shall be performed for each individual case
- Type-tested design tables may be used

Determining of initial forces:

- Only with linear-elastic analysis
- Analysis with redistribution, plastic analysis and non-linear analysis may not be used
- The principles for the design of frameworks in accordance with EN 1992-1-1 section 5.6.4 shall be used
- Strut-and-tie models in accordance with Annexes D3 and D4 with $z = z_{\text{strut-and-tie}}$
- Internal forces M_{Ed} and V_{Ed} shall be applied on the reference axis
- Shear reinforcements only receive tensile forces
- Variable moments and shear forces along the slab edges shall be taken into account (see section B.1.1)
- The shear force reinforcement required in the insulation layer does not determine the minimum slab thickness in accordance with EN 1992-1-1, section 9.3.2(1)

On-site vertical reinforcement on the adjacent surfaces facing the insulation of the components:

- The required vertical reinforcement results from the supporting and splitting tensile reinforcement, whereby at least a subsidiary structural edge reinforcement in accordance with section B.2.2 shall be provided

$$V = \max \left\{ \begin{array}{l} R \\ A+S \end{array} \right.$$

with:

V	...	on-site vertical reinforcement
R	...	subsidiary structural edge reinforcement in accordance with section B.2.2
A	...	supporting reinforcement
S	...	splitting reinforcement

- A – Supporting reinforcement

A supporting reinforcement is needed on the balcony side, if the number of the compression or tension elements is higher than the number of the shear bars. The required supporting reinforcement (and subsidiary structural edge reinforcement) covers the entire height up to the tension chord of the connected component.,

positive shear forces (directed downwards):

negative shear forces (directed upwards):

$$A = \frac{V_{Ed}}{f_{yd}} \cdot \left(1 - \frac{n_{Q\text{-Stab}(+)}}{n_{CE}} \right) \text{ where } \frac{n_{Q\text{-Stab}(+)}}{n_{CE}} \leq 1$$

$$A = \frac{V_{Ed}}{f_{yd}} \cdot \left(1 - \frac{n_{Q\text{-Stab}(-)}}{n_{ZS}} \right) \text{ where } \frac{n_{Q\text{-Stab}(-)}}{n_{ZS}} \leq 1$$

where:

A	...	required supporting reinforcement
$n_{Q\text{-Stab}}$...	number of positive (+) or negative (-) shear force bars
n_{CE}	...	number of compression elements
n_{ZS}	...	number of tension elements
V_{Ed}	...	total acting shear force

Schöck Isokorb® with steel compression elements

Structural Analysis
General

Annex D1

- S – splitting reinforcement
 - Balcony side:

$$Z_{Sd} = 0,25 \cdot D_{Ed} \left(1 - \frac{a}{2 \cdot e'}\right)$$

$$S_B = \frac{Z_{Sd}}{f_{yd}}$$
 where:
 - Z_{Sd} ... resultant splitting tensile force
 - D_{Ed} ... orthogonal and cantered compression force acting on the subarea in accordance with Annexes D3 and D4
 - a ... height of the steel plate of the SCE
 - e' ... distance of the SCE to the nearest edge; $e' = \min(c_1; h - c_1)$
 - h ... high of construction product
 - c_1 ... edge distance of the load resultants in accordance with Annexes D3 and D4
 - S_B ... required splitting reinforcement on the balcony side
 - Floor side:

$$S_D = \begin{cases} 0 & \text{for direct support} \\ S_B & \text{for indirect support} \end{cases}$$
 where:
 - S_D ... required splitting reinforcement on the slab side
- If the shear force is pointing up (lifting) or the compression chord is above and the tension chord is underneath, the statements for the on-site vertical reinforcement shall be analogously adapted for the contrary load transfer
- Inclusion as a vertical reinforcement:
 - Subsidiary structural edge reinforcement in accordance with section B.2.2
 - Lattice girders with a maximum distance of 100 mm from the insulation joint
 - Vertical legs of the shear force bars for Isokorb® types K and K-F if the axial edge distance between shear reinforcement and tension reinforcement ≤ 2 cm

Schöck Isokorb® with steel compression elements

Structural Analysis
General

Annex D2

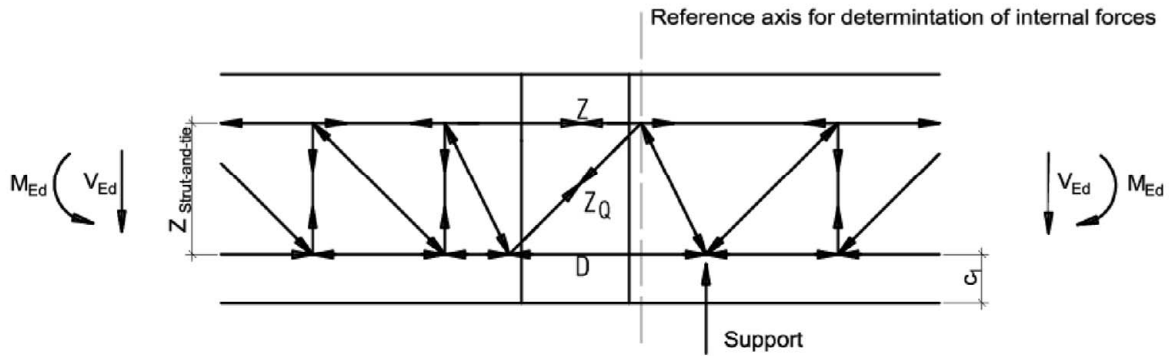

Fig. 36: Schöck Isokorb® type K and K-F (version segmented) (type O analog)

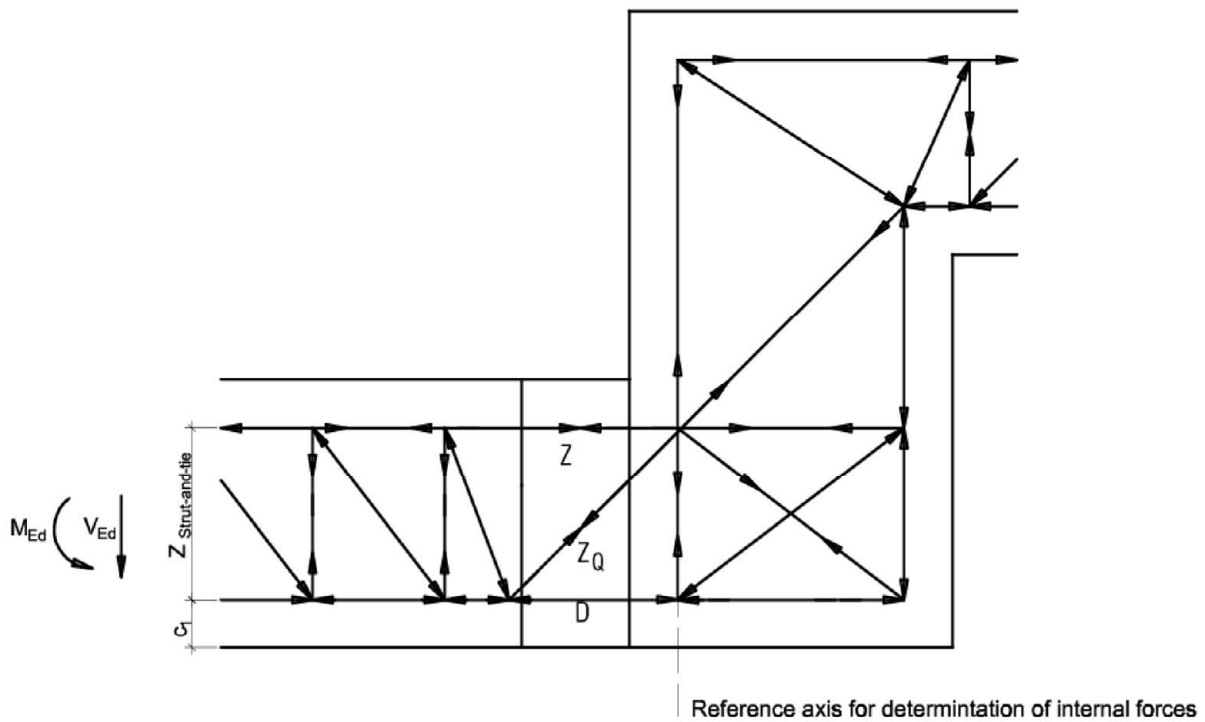

Fig. 37: Schöck Isokorb® type K-HV

Schöck Isokorb® with steel compression elements

Structural Analysis
Strut-and-tie models
Insulation thickness 60 - 120 mm

Annex D3

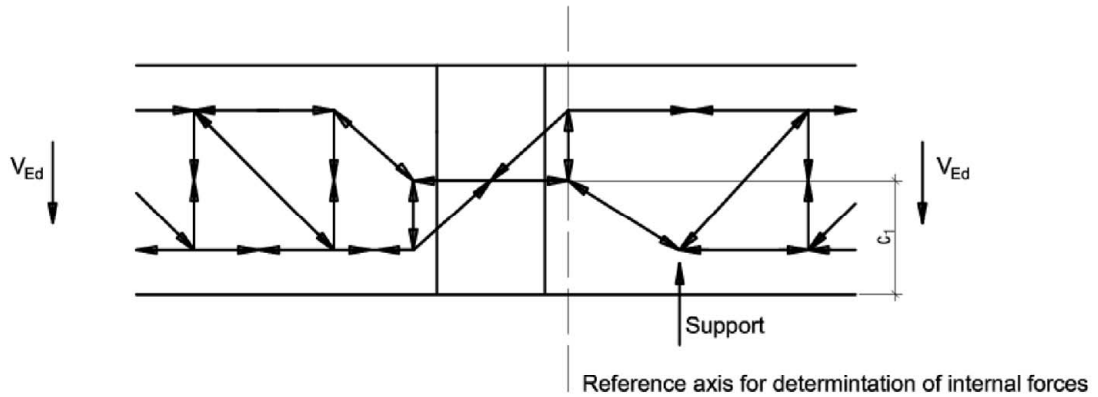

Fig. 38: Schöck Isokorb® type Q

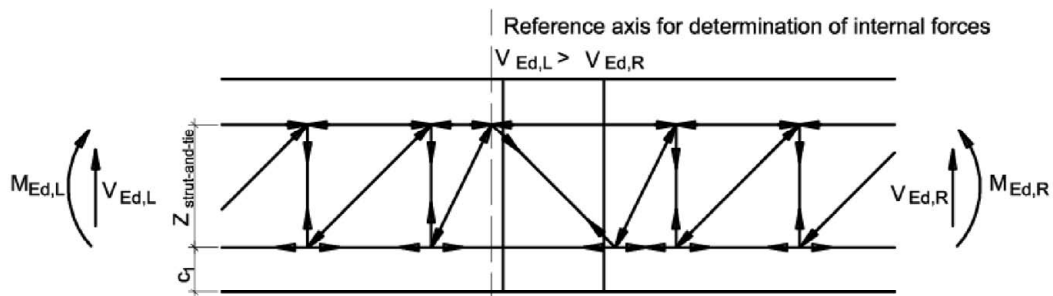

Fig. 39: Schöck Isokorb® type D (type A and type F analog)*

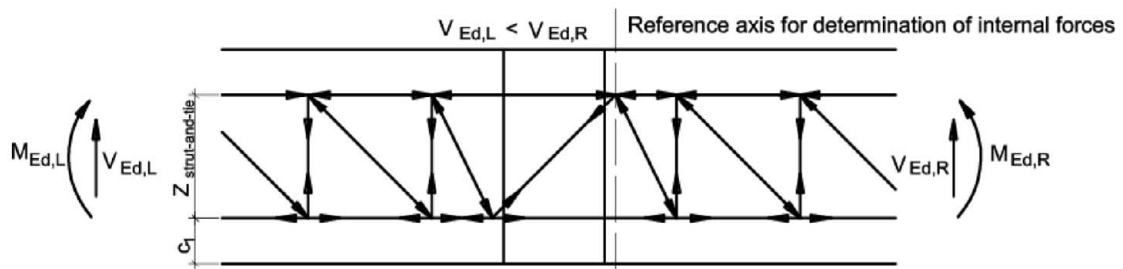

Fig. 40: Schöck Isokorb® type D (type A and type F analog)*

*the reference axis can alternatively be taken at the middle of the joint

Schöck Isokorb® with steel compression elements

Structural Analysis
Strut-and-tie models
Insulation thickness 60 - 120 mm

Annex D4

D.1.2 Ultimate limit states

D.1.2.1 Verification of compression bars

- The resistance values that can be applied for verification are given in Table C.2
- With use of the compression bars with welded-on compression plates the introduction of the compressive stresses into the concrete as a partial surface load in accordance with EN 1992-1-1, section 6.7 shall be verified
- Superimposition of adjacent load distribution surfaces shall be taken into consideration
- It shall be verified that the occurring tensile forces can be transferred

D.1.2.2 Verification of the tensile bars and shear force bars

- Verification in accordance with EN 1993-1-4 with design values in accordance with Table C.1
- Load-bearing capacity of the welded joint between reinforcing steel and stainless reinforcing steel or round steel does not need to be performed separately

D.1.2.3 Shear force resistance in the area of insulation joint

- Shear force resistance of the connecting slabs shall be carried out in consideration of EN 1992-1-1, section 6.2
- The required verification of the mandrel diameter can be omitted if the following conditions are observed:
 - o Mandrel diameter specifications given in Annexes B5-B10, D7-D9
 - o The shear force bar axis spacing on average in the centre and to the free edge or the expansion is ≥ 10 cm (section A.2)
- Axis spacing < 10 cm: verification of the necessary mandrel diameter in accordance with EN 1992-1-1, section 8.3 shall be provided

D.1.2.4 Verification of the fatigue due to temperature difference

- Verification through the limitation of the joint spacing in the external structural components in accordance with Table B.1

D.1.2.5 Provisions of the verifications in the load introduction area of the concrete components

- Shear force load-bearing capacity of the undisturbed slabs in accordance with EN 1992-1-1, section 6.2
- A shear force distributed evenly across the concrete compression area shall be taken as a basis, especially for the design value of the shear force load-bearing capacity of the slabs without shear force reinforcement. Therefore the elements shall be installed with uniform spacing.

Schöck Isokorb® with steel compression elements

Structural Analysis
Ultimate limit states

Annex D5

D.1.2.6 Anchorage lengths and overlap joints of the bars leading through the thermal insulation layer

- Only ribbed steel can be taken into account for anchorage lengths and overlap joints
- The tensile bars shall be lapped to the tensile bars of the adjacent slabs
- With use of graduated tensile bars (see Annex A4) the increase in the overlap length Δl_0 in accordance with Annex A4, Table A.1 shall be taken into account
- Anchorage of the shear force bars in the slabs in accordance with Annex D7 and D8, insofar as higher values are not yielded in accordance with EN 1992-1-1, equation (8.10)
- In cases in which shear force bars and compression members are not placed on a plane, the anchorage length for shear force bars shall also be determined in the compression zone as in the tensile zone
- Compression bars shall be anchored in the slabs at least with l_{bd} in accordance with EN 1992-1-1

Shear reinforcement in accordance with EN 1992-1-1, section 8.7.4 shall be placed in the overlap area of the bars at an axial distance > 20 mm and anchored to the section edge to resist the arising transverse tensile forces in addition to the shear reinforcement in accordance with EN1992-1-1 section 8.7.4.1.

Grading of the tensile reinforcement in the areas of the Schöck Isokorb® shall not be permitted.

Slab connections exclusively transfer shear forces:

- The tensile reinforcement of the slab to be connected shall be anchored in the compression zone on the frontal side with hooks
- Alternatively, stirrups on every shear force bar or lattice girders, with use of lattice girders, the tensile reinforcement must lie over the lower chords of the lattice girders (see also section B.2.2)
- The version of the shear force bar in bent form shall be possible, if the design details specified in Annex D9 are implemented

Schöck Isokorb® with steel compression elements

Structural Analysis
Ultimate limit states

Annex D6

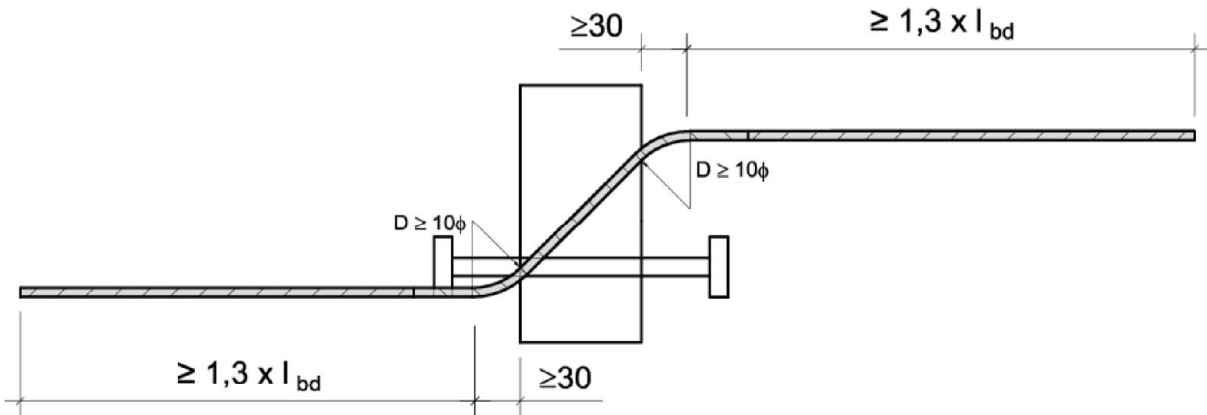

Fig. 41: Schöck Isokorb® type K/K-F (version segmented)

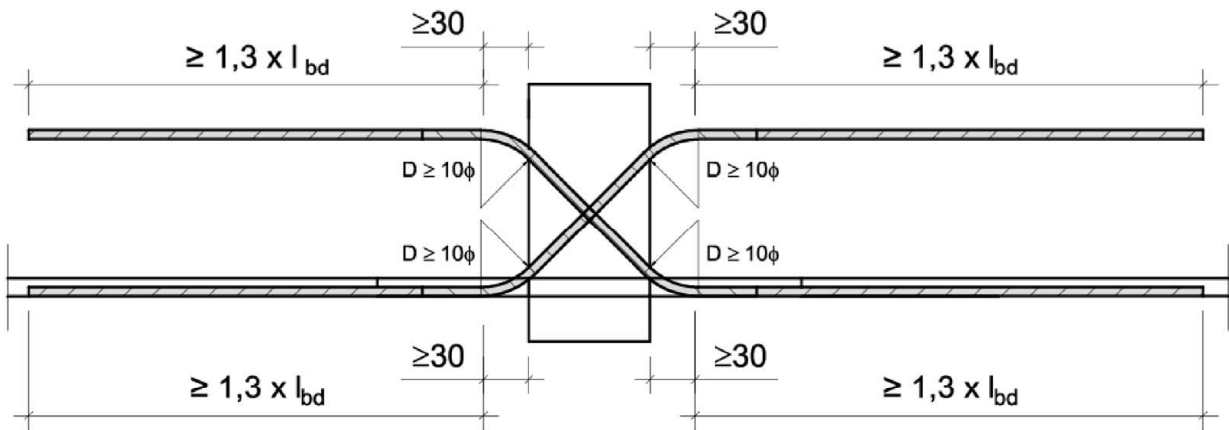

Fig. 42: Schöck Isokorb® type D

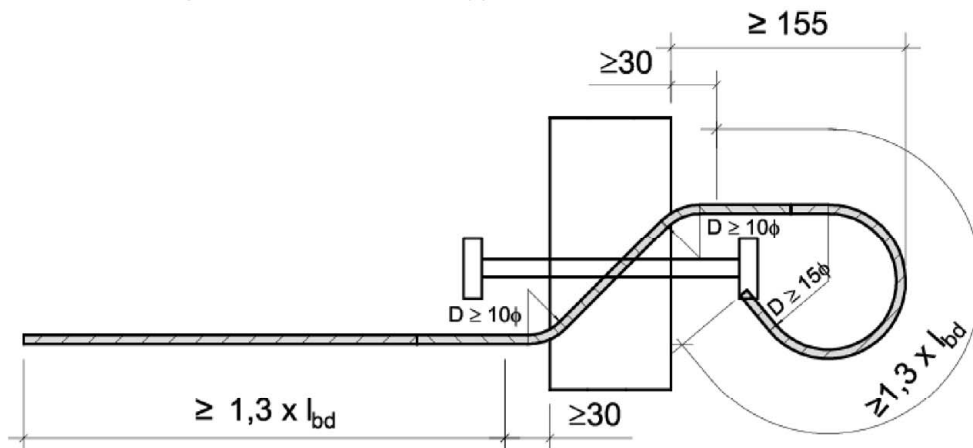

Fig. 43: Schöck Isokorb® type Q with and without execution as edge beam

where $l_{bd} \geq l_{b,min}$ as per EN 1992-1-1

Schöck Isokorb® with steel compression elements

Structural Analysis

Shear force bar anchoring and overlap length with SCE
Insulation thickness 60 - 120 mm

Annex D7

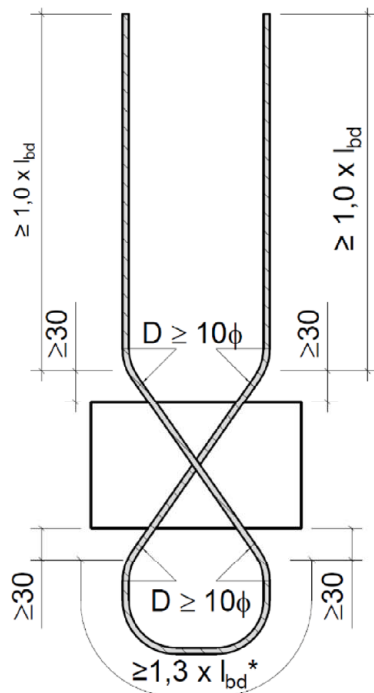

Fig. 44: Schöck Isokorb® type A

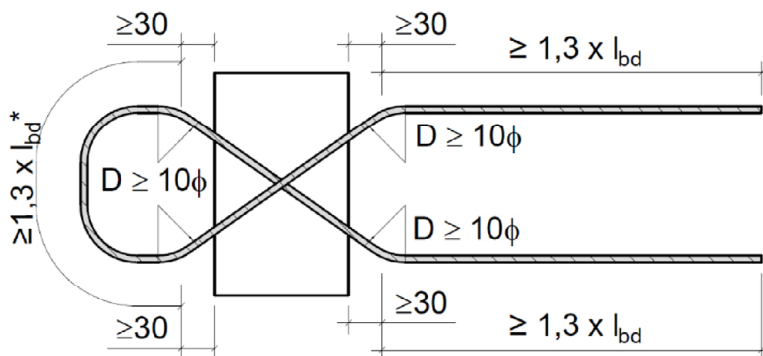

Fig. 45: Schöck Isokorb® type F

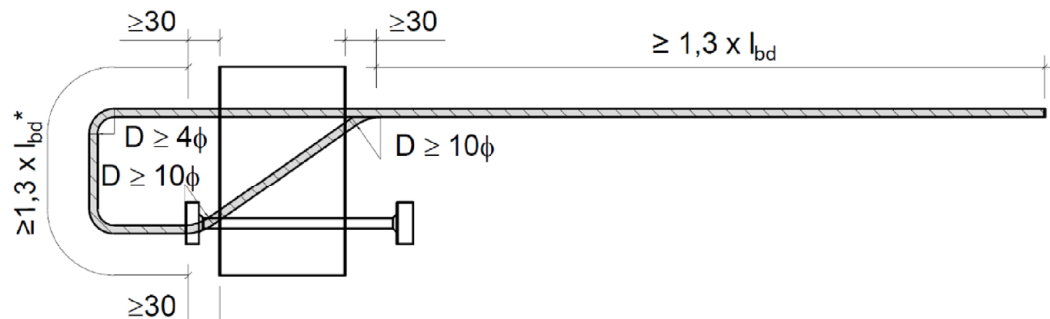

Fig. 46: Schöck Isokorb® type O

where $l_{bd} \geq l_{b,min}$ as per EN 1992-1-1
* with $\alpha_1 = 0,7$

Schöck Isokorb® with steel compression elements

Structural Analysis

Shear force bar anchoring and overlap length with SCE
Insulation thickness 60 - 120 mm

Annex D8

Schöck Isokorb® type Q

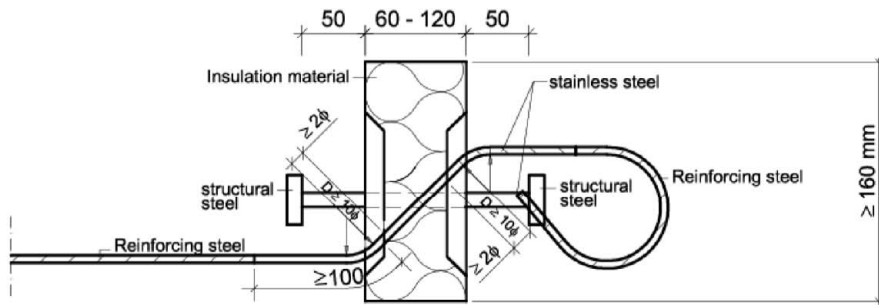

Fig. 47: Schöck Isokorb® type Q with SCE

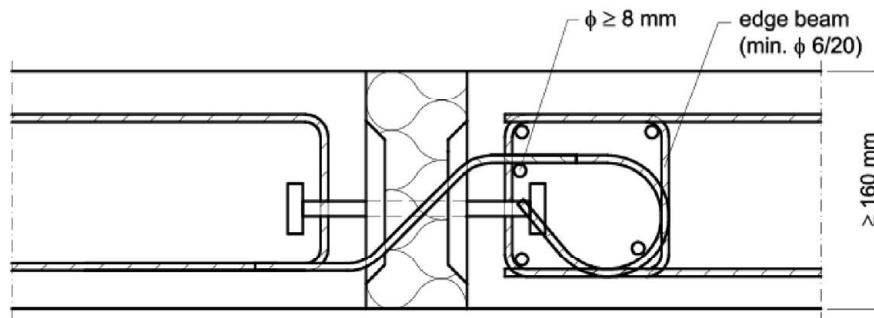

Fig. 48: Example of a Schöck Isokorb® type Q with SCE and execution as edge beam

Schöck Isokorb® with steel compression elements

Structural Analysis
Type Q with SCE
Insulation thickness 60 - 120 mm

Annex D9

D.1.3 Serviceability limit states

D.1.3.1 Control of cracking

- EN 1992-1-1, section 7.3
- An additional verification does not need to be provided on the front faces of the joints or in the load introduction area if the provisions of this European technical assessment are complied with

D.1.3.2 Deflection control

In the calculation of the vertical deformations, the following influential factors shall be taken into account:

- Elastic deformations of the load-bearing thermal insulation element and of the adjacent slab concrete
- Thermal expansions

Verification of the deflections:

- Quasi-continuous combination in accordance with Annexes D11 and D12
- Model for determining the bending deformation in the joint in accordance with Annexes D11 and D12
- Calculation of the elastic deformations of the tension bars depending on the yield strength that can be applied (Table C.1)

Schöck Isokorb® with steel compression elements

Structural Analysis
Serviceability limit states

Annex D10

Elongation of strap: $\Delta l_t = \epsilon_t \cdot l_{\text{eff},t}$

Elongation of compression flange $\Delta l_d = \epsilon_d \cdot l_{\text{eff},d}$

According to Fig. 50 $E_t = E_d = 160.000 \text{ N/mm}^2$

According to Fig. 51 $E_t = E_d = 170.000 \text{ N/mm}^2$

Angle of rotation in the joint: $\tan \alpha_{\text{joint}} = (\epsilon_t \cdot l_{\text{eff},t} - \epsilon_d \cdot l_{\text{eff},d}) / z$

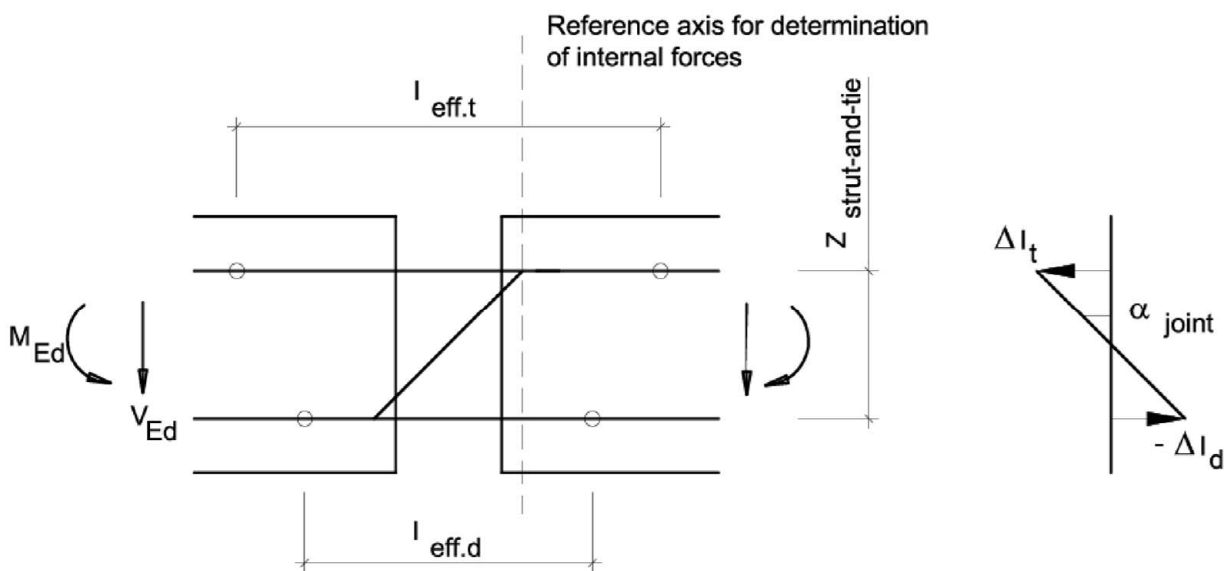

Fig. 49: Model for determining the bending deformation in the joint

Schöck Isokorb® with steel compression elements

Structural Analysis

Model for determining the bending deformation on the joint
Insulation thickness 60 - 120 mm

Annex D11

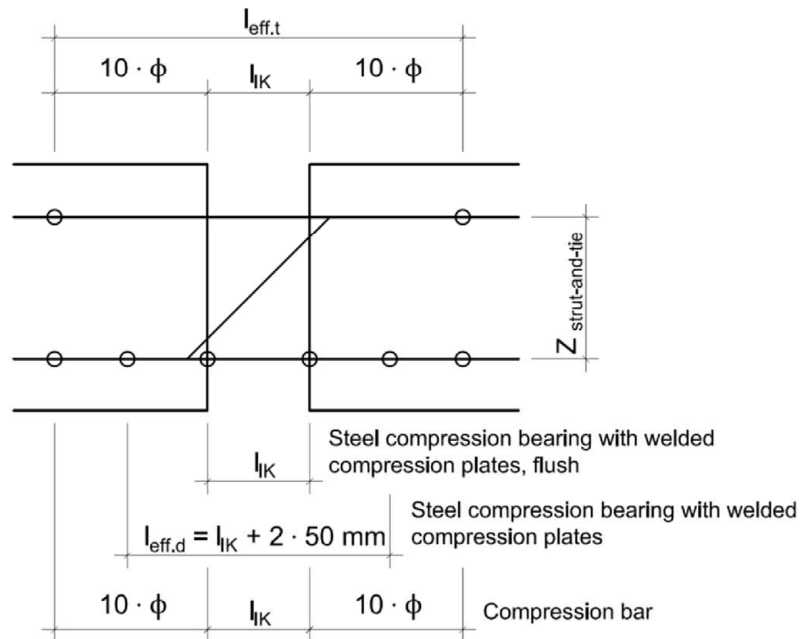

Fig. 50: I_{eff} for ribbed stainless steel bar, as per section A.3

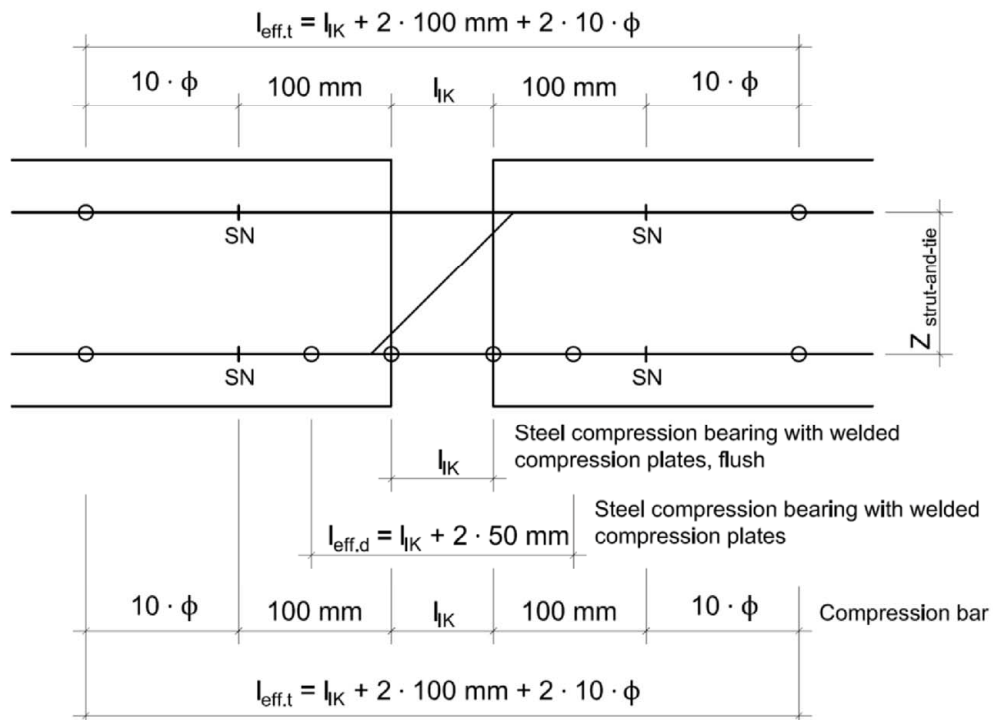

Fig. 51: I_{eff} for plain stainless steel bar with strength classes S355, S460 and S690, as per section A.3

Schöck Isokorb® with steel compression elements

Structural Analysis
Determination of I_{eff}
Insulation thickness 60 - 120mm

Annex D12