

Technical Information



**Telephone hotline for
design support services**

Tel.: 0845 241 3390

Fax: 0845 241 3391

E-mail: design@schoeck.co.uk



**Planning tools -
downloads and requests**

Tel.: 0845 241 3390

Fax: 0845 241 3391

E-mail: design@schoeck.co.uk

Web: www.schoeck.co.uk



**CPD Seminars and
on-site consultation**

Tel.: 0845 241 3390

Fax: 0845 241 3391

Web: www.schoeck.co.uk

Schöck Isokorb® Certificates

Schöck Isokorb® range of load-bearing thermal insulation components, if used in accordance with the provisions of the BBA Approval, Agreement Certificate No 05/4277 and No 10/4801, will meet the relevant requirements.

The static calculations to Eurocode 2 for the Schöck Isokorb®, when used in conjunction with BS EN 1992-1-1:2004 and its UK National Annex, have been approved by Mr. Rod Webster, the Concrete Innovation & Design, West Sussex.

The static calculations to Eurocode 3 for Schöck Isokorb® type KST, when used in conjunction with BS 5950-1:2000 and Steel Construction Institute Publication P291, have been approved by Mr. David MacKenzie, the Flint & Neill Partnership, London.

These documents can be downloaded from www.schoeck.co.uk.

Schöck Bauteile GmbH
Virmbucher Strasse 2
D-75334 Baden-Baden
Germany
Tel: 00 49 72 23 0670 Fax: 00 49 72 23 067430
e-mail: www@schock.de
website: www.schoeck.de



BBA
Approval
Agreement Certificate
No 05/4277
Product Sheet 1

**Agreement Certificate
05/4277
Product Sheet 1**

SCHÖCK ISOKORB RANGE OF LOADBEARING THERMAL INSULATION COMPONENTS

SCHÖCK ISOKORB LOADBEARING THERMAL INSULATION FOR CONCRETE FLOORS

PRODUCT SCOPE AND SUMMARY OF CERTIFICATE

This Certificate relates to Schöck Isokorb Loadbearing Thermal Insulator for Concrete Floors, for use in reinforced concrete structures to form a thermal break between a balcony and an internal floor, while transferring load and maintaining full structural integrity.

AGREEMENT CERTIFICATION INCLUDES:

- factors relating to compliance with Building Regulations where applicable
- factors relating to additional non-regulatory information where applicable
- independently verified technical specifications
- assessment criteria and technical investigations
- design considerations
- installation guidance
- regular surveillance of production
- formal five yearly review

KEY FACTORS ASSESSED

Structural aspects – the products have adequate strength to resist the loads associated with permanent loading (see section 5)

Thermal performance – the products contribute towards the overall thermal insulation of the building envelope by reducing cold bridging between internal and external elements (see section 6)

Behaviour in relation to fire – testing indicates that fire protection glazes incorporated in the products will provide up to 90 minutes resistance (see section 8)

Durability – under normal service conditions, the products will have a service life of at least 50 years (see section 10)

The BBA has awarded this Agreement Certificate to the company named above for the products described herein. These products have been assessed by the BBA as being fit for their intended use provided they are installed, used and maintained as set out in this Certificate.

On behalf of the British Board of Agreement

Date of First Issue: 17 May 2011

Brian Chamberlain *Graig Cooper*
Head of Approval – Engineering Chief Executive

The BBA is a UKAS accredited certification body – Number 113. The details of the current scope of accreditation for product certification is available in full format on the UKAS site on the BBA website at www.bba.org.uk



Resolves are published to check the validity and issue new number of this Agreement Certificate by either referring to the BBA website or contacting the BBA Direct

British Board of Agreement
Buckingham Palace
London, W1A 0AA
Phone: 020 7553 0344

Tel: 01292 565300
Fax: 01292 565303
e-mail: enquiries@bba.org.uk
website: www.bba.org.uk

©2011 Page 1 of 12

Schöck Bauteile GmbH
Virmbucher Strasse 2
D-75334 Baden-Baden
Germany
Tel: 00 49 72 23 0670 Fax: 00 49 72 23 067430
e-mail: www@schock.de
website: www.schoeck.de



BBA
Approval
Agreement Certificate
No 10/4801
Product Sheet 1

**Agreement Certificate
10/4801
Product Sheet 1**

SCHÖCK ISOKORB RANGE OF THERMAL INSULATION COMPONENTS

SCHÖCK ISOKORB CONNECTORS – TYPE KST MODULES

PRODUCT SCOPE AND SUMMARY OF CERTIFICATE

This Certificate relates to Schöck Isokorb Connectors – Type KST Modules, for connecting steel to steel or to concrete structures, where it is necessary to reduce floor height.

AGREEMENT CERTIFICATION INCLUDES:

- factors relating to compliance with Building Regulations where applicable
- factors relating to additional non-regulatory information where applicable
- independently verified technical specifications
- assessment criteria and technical investigations
- design considerations
- installation guidance
- regular surveillance of production
- formal five yearly review

KEY FACTORS ASSESSED

Mechanical resistance and stability – the modules have been designed to transfer the loads from steel beams to the steel or concrete structure (see section 5)

Behaviour in relation to fire – the modules will require the same fire resistance on the main structure (see section 6)

Hygrothermal performance – the modules can contribute to limiting surface condensation risk and excessive outdoor heat loss (see section 7)

Durability – the modules are made from stainless steel giving adequate protection against corrosion (see section 9)

The BBA has awarded this Agreement Certificate to the company named above for the products described herein. These products have been assessed by the BBA as being fit for their intended use provided they are installed, used and maintained as set out in this Certificate.

On behalf of the British Board of Agreement

Date of First Issue: 9 December 2010

Brian Chamberlain *Graig Cooper*
Head of Approval – Engineering Chief Executive

The BBA is a UKAS accredited certification body – Number 113. The details of the current scope of accreditation for product certification is available in full format on the UKAS site on the BBA website at www.bba.org.uk



Resolves are published to check the validity and issue new number of this Agreement Certificate by either referring to the BBA website or contacting the BBA Direct

British Board of Agreement
Buckingham Palace
London, W1A 0AA
Phone: 020 7553 0344

Tel: 01292 565300
Fax: 01292 565303
e-mail: enquiries@bba.org.uk
website: www.bba.org.uk

©2010 Page 1 of 8



Concrete Innovation & Design
CONSULTANTS IN
STRUCTURAL ANALYSIS, DESIGN & SOFTWARE

17 Abercromby
Chichester
West Sussex
PO19 1SU
Phone: 01243 711335
E-mail: enquiries@concreteinnovation.org.uk

Paul Lambert
Managing Director

14 Haggerston
BPM (F) 35C

PROOFREAD
Brent Lambert
BSc, CEng, MICE, MInstE

Neil Brown
BSc, CEng, MICE, MInstE

11th October 2010

Advisory opinion
on the validity of
Static calculations to Eurocode 2
for
Schöck Isokorb thermal insulation components
when used in conjunction with
BS EN 1992-1-1:2004 and its UK National Annex

Commissioned by:
Schöck Bauteile GmbH
Virmbucher Strasse 2
75334 Baden-Baden

www.cid.co.uk

Flint & Neill Partnership
Consulting Engineers

1130 - Schöck Isokorb KST Units – Assessment Certificate

Following a detailed structural assessment of the KST modules listed below,

- KST 16
- KST 22
- KST-OST 16 Module
- KST-ZOST 16 Module
- KST-OST 22 Module
- KST-ZOST 22 Module
- KST-ZST 16 Module
- KST-ZST 22 Module

Using Schöck Fabrication drawings 25833001-A and 25833003-A in conjunction with the mechanical properties listed in the KST design manual.

We certify that the manufacturer's recommended design capacities in the KST design manual do not exceed the maximum design strengths predicted by the following codes:-

- BS 5850-1:2000 Structural Use of Steelwork in Building
as amended by:-
Steel Construction Institute Publication P291 – Structural design of Stainless Steel

Detailed assessment calculations are contained in Flint & Neill Partnership report 1130-RP02-v1 dated October 2006.

Signed: 
Name: C.J. Murphy
Engineering Qualifications: MEng CEng MICE MStructE
Position Held: Check Team Leader – Flint & Neill Partnership

Signed: 
Name: D.K. MacKenzie
Position Held: Partner – Flint & Neill Partnership
Date: 20th October 2006

www.flintneill.co.uk

Schöck Isokorb®

Contents

	Page
Building physics	5 - 17
Thermal bridges	5 - 9
The balcony as a thermal bridge	10 - 13
Equivalent thermal conductivity λ_{eq}	14 - 15
Fire resistance classes	16 - 17
Reinforced concrete-to-reinforced concrete	18 - 134
An overview of all types	18 - 21
Basic information	22 - 23
Structural design and calculation program	24 - 25
FEM guidelines	26 - 27
Materials of concrete-to-concrete applications	28
Schöck Isokorb® selection	29 - 133
Construction details	134
Reinforced concrete-to-steel	136 - 167
An overview of all types	136 - 137
Materials/Anti-corrosion protection/Fire protection	138
Schöck Isokorb® selection	139 - 165
Construction details	166
Check list	158 + 167
Steel-to-steel	168 - 199
An overview of all types	168 - 169
Materials/Anti-corrosion protection/Fire protection	170
Schöck Isokorb® selection	171 - 197
Construction details	198
Check list	199
Further products	200 - 203

Schöck Isokorb®

Features

Schöck Isokorb® with HTE modules for thermally efficient load-bearing connection between reinforced concrete-to-reinforced concrete

- ▶ provides a thermal break between external reinforced concrete components and the building
- ▶ reduces thermal losses to a minimum by virtue of innovative technology (HTE module pressure bearings)
- ▶ plastic jackets on the concrete pressure bearings provide trouble-free movement
- ▶ thus helps to save heating bills, reduce CO₂ emissions and conserve natural energy resources
- ▶ eliminates the risk of condensation
- ▶ flush-mounted pressure bearings (HTE modules) facilitate installation on the construction site and in prefabricating plants

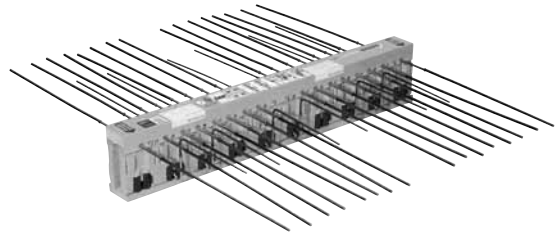

Schöck Isokorb® type K

Schöck Isokorb® for thermally efficient load-bearing connection between reinforced concrete-to-steel

- ▶ allows thermally insulated connections between steel to reinforced concrete components
- ▶ enables a high level of prefabrication
- ▶ minimises on-site assembly time
- ▶ components exposed to the weather are made of stainless steel, thus offering protection against corrosion

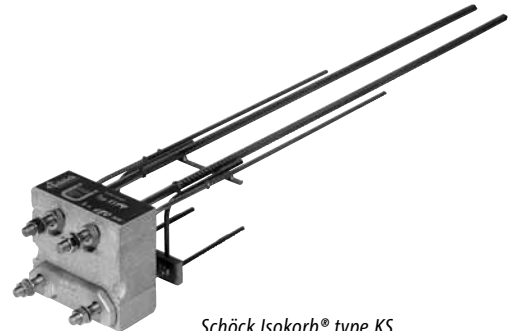

Schöck Isokorb® type KS

Schöck Isokorb® for thermally efficient load-bearing connection between steel-to-steel

- ▶ allows thermal breaks to be incorporated in steel structures, whilst simultaneously being capable of transmitting high loads
- ▶ state-of-the-art components for the avoidance of thermal bridges in steel construction in accordance with the BRE IP 1/06
- ▶ enables a high level of prefabrication
- ▶ modular layout means that the system can be used for connections with all profile sizes and structural loads
- ▶ guarantees shortest planning and assembly times



Schöck Isokorb® type KST

Building physics

Thermal bridges

Definition of thermal bridges

Thermal bridges are localised regions in building envelope details which display increased thermal losses. The increased thermal losses can be caused by the component geometry (“geometric thermal bridge”) or by the localised inclusion of materials with a higher thermal conductivity in the affected component (“material-based thermal bridge”).

Effects of thermal bridges

In the area of a thermal bridge, the local increase in thermal losses causes the temperature of inside surfaces to drop. Mould will form as soon as the surface temperature drops below the so-called “mould temperature” θ_s . If the surface temperature drops even further – to below the dewpoint temperature θ_t – the moisture present in the room air will condense on the cold surfaces in the form of droplets.

Once mould has formed in the area of a thermal bridge, the spores released by it into the room can represent a serious health hazard to anybody living in the room. Mould spores are allergens which can cause severe allergic reactions in humans, such as sinusitis, rhinitis and asthma. As exposure inside the house or apartment is usually prolonged, there is a high risk that these allergic reactions can develop into chronic conditions.

In summary, the effects of thermal bridges are therefore:

- ▶ Risk of mould formation
- ▶ Risk of health damage (allergies etc.)
- ▶ Risk of condensation
- ▶ Increased wastage of heating energy

Dewpoint temperature

The dewpoint temperature θ_t of a room is the temperature at which the moisture present in the air in the room can no longer be supported by the air and condenses in the form of water droplets. At this point the relative humidity is then 100 %.

Room air which is in direct contact with the surfaces of colder areas take the temperature of the cold surface as a result of this direct contact. If the minimum surface temperature of a thermal bridge is below the dewpoint temperature, then the temperature of the air directly adjacent to this surface will also be below the dewpoint temperature. As a consequence, the moisture contained in this layer of room air condenses on the cold surface.

The dewpoint temperature only depends on the temperature and the humidity of the air in the room (see figure 1, page 8). The higher the humidity and temperature of the air in the room, the higher the dewpoint temperature – i.e. the sooner condensation forms on colder surfaces.

On average, standard climatic conditions in a room are around 20 °C with a relative humidity of approximately 50 %. This results in a dewpoint temperature of 9.3 °C. In rooms where the humidity is higher, e.g. in a bathroom, the humidity may also reach a value of 60 % or higher. The dewpoint temperature is correspondingly higher, and the risk of condensation forming increases. For example, if the humidity of the room air is 60 % the dewpoint temperature is already 12.0 °C (see figure 1, page 6). The steeply ascending curve in Figure 1 gives a very clear indication of how closely the dewpoint temperature depends on the humidity of the room air: even slight increases in the humidity of the room air lead to a significant increase in the dewpoint temperature of the room air. This results in a significant increase in the risk of condensation forming on the cold component surfaces.

Building physics

Thermal bridges

Mould temperature

At room air relative humidity values of 80 % or higher the surface moisture on components is sufficient for mould to grow, i.e. mould will grow on the surface of cold components if the component surface is cold enough to generate a humidity of 80 % in the layer of air directly adjacent to the component. The temperature at which this occurs is referred to as the so-called “mould temperature” θ_s .

This means that mould growth already takes place at temperatures above the dewpoint temperature. At a room climate of 20 °C/50 % the mould temperature is 12.6 °C, i.e. 3.3 °C higher than the dewpoint temperature. As a result, from the point of view of avoiding building damage (i.e. mould formation), the mould temperature is therefore more important than the dewpoint temperature. It is not sufficient for the inside surfaces to be warmer than the dewpoint temperature of the room air – the surface temperatures must also be above the mould temperature.

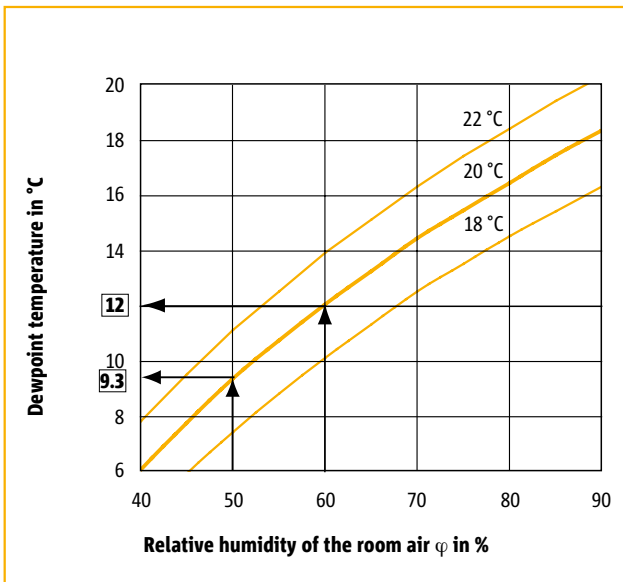

Figure 1: Dependency of the dewpoint temperature on the room air humidity and temperature

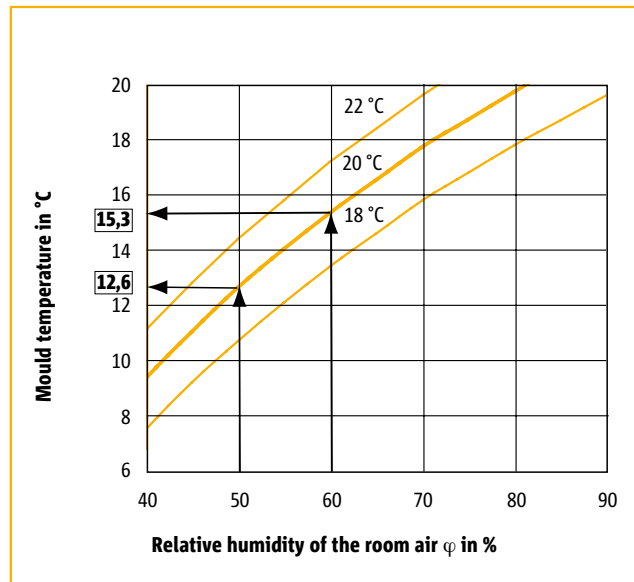

Figure 2: Dependency of the mould temperature on the room air humidity and temperature

Building physics

Thermal bridges

Thermal characteristics of thermal bridges

The thermal effects of thermal bridges are described by the following thermal characteristics:

Thermal effects	Characteristic values	
	Qualitative representation	Quantitative single value representation
<ul style="list-style-type: none"> ▶ Formation of mould ▶ Formation of condensation 	<ul style="list-style-type: none"> ▶ Isothermals 	<ul style="list-style-type: none"> ▶ Minimum surface temperature θ_{\min} ▶ Temperature factor f_{Rsi}
<ul style="list-style-type: none"> ▶ Thermal loss 	<ul style="list-style-type: none"> ▶ Heat flow lines 	<ul style="list-style-type: none"> ▶ ψ value ▶ χ value

These characteristic values can only be determined by means of a thermal FE calculation of the thermal bridge. To do this, the geometric layout of the structure in the area of the thermal bridge is modelled on a computer together with the thermal conductivity values of the materials used. The boundary conditions which should be applied to the calculations and to the models are governed by BS EN ISO 10211-1:1996 and BS EN ISO 10211-2:2001.

In addition to the quantitative characteristic values, the FE calculation also yields a representation of the temperature distribution within the structure (representation of “isothermals”) and the layout of the heat flow lines. The heat flow line representation shows the paths on which heat is lost through the structure and offers good insight into the weak spots of the thermal bridge. The “isothermals” are lines or areas of the same temperature. They show the temperature distribution within the analysed component. Isothermals are often graded with a temperature increment of 1 °C. Heat flow lines and isothermals are always perpendicular to each other (see Figures 3 and 4).

The thermal transmission coefficients ψ and χ

The linear thermal transmission coefficient ψ (“psi value”) describes the additional thermal losses per meter of a linear thermal bridge. Correspondingly, the thermal transmission coefficient χ (“chi value”) describes the additional thermal losses through a point-shaped thermal bridge.

Depending on whether the surfaces used to determine the ψ value relate to external or internal dimensions, a distinction is made between ψ values which relate to external and internal dimensions. The thermal insulation calculations in accordance with the Energy Saving directive must be based on ψ values which relate to external dimensions. Unless specified otherwise, all of the ψ values in this technical information document relate to external dimensions.

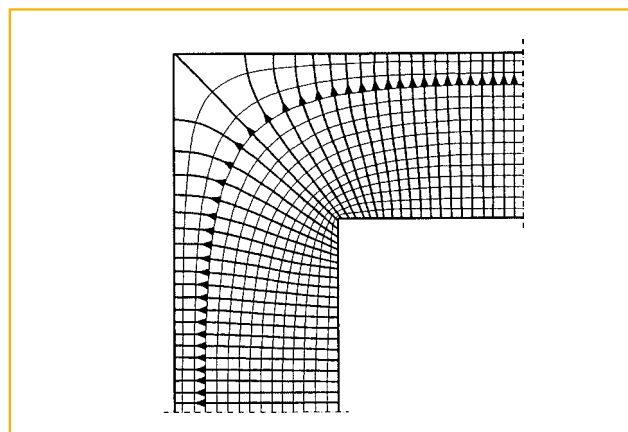

Figure 3: Example of a thermal bridge which is caused purely by the geometry of the component (“geometric thermal bridge”). Representation of the isothermals and heat flow lines (arrows).

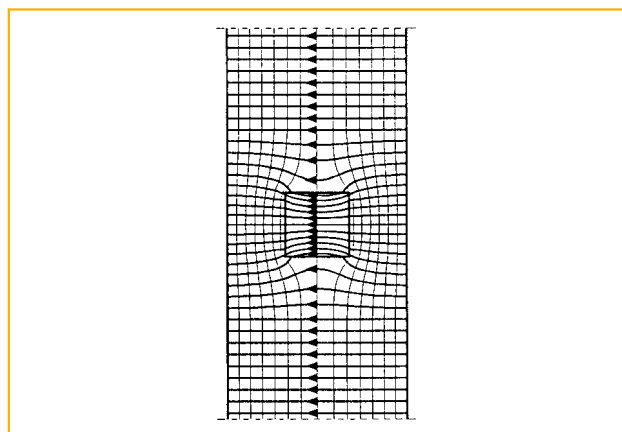

Figure 4: Example of a thermal bridge which is caused purely by the choice of materials (“material-based thermal bridge”). Representation of the isothermals and heat flow lines (arrows).

Building physics

Thermal bridges

The minimum surface temperature θ_{min} and the temperature factor f_{Rsi}

The minimum surface temperature θ_{min} is the lowest inside surface temperature occurring in the region of a thermal bridge. The value of the minimum surface temperature θ_{min} is the deciding factor which determines whether condensation forms at a thermal bridge or whether mould starts to grow there. Accordingly, the minimum surface temperature is an indicator of the effects of a thermal bridge in terms of dampness.

The characteristic values θ_{min} and the ψ value depend on the layout and structure of the thermal bridge (geometry and thermal conductivity of the materials which form the thermal bridge). In addition, the minimum surface temperature also depends on the prevailing outside temperature. The lower the outside air temperature, the lower the minimum surface temperature (see Figure 5).

As an alternative to the minimum surface temperature, the temperature factor f_{Rsi} can also be used as a dampness indicator. The temperature factor f_{Rsi} is the temperature difference between the minimum surface temperature and the outside air temperature ($\theta_{min} - \theta_e$) divided by the temperature difference between the inside temperature and outside temperature ($\theta_i - \theta_e$):

$$f_{Rsi} = \frac{\theta_{min} - \theta_e}{\theta_i - \theta_e}$$

As the f_{Rsi} value is a relative value, it offers the advantage that it only depends on the construction of the thermal bridge, and not on the prevailing inside and outside temperatures like θ_{min} . If the f_{Rsi} value of a thermal bridge is known, the minimum surface temperature can be calculated for specific inside and outside air temperatures:

$$\theta_{min} = \theta_e + f_{Rsi} \times (\theta_i - \theta_e)$$

Figure 5 shows the dependency of the minimum surface temperature on the adjacent outside temperature as a function of different f_{Rsi} values with a constant inside temperature of 20 °C.

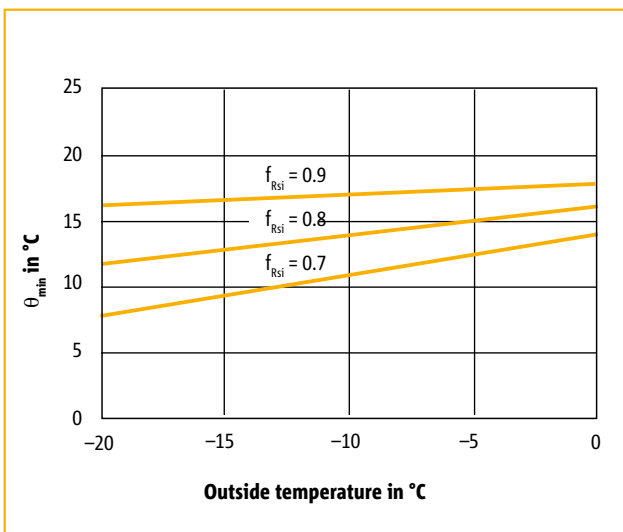

Figure 5: Dependency of the minimum surface temperature on the adjacent outside temperature (Inside temperature at a constant value of 20 °C).

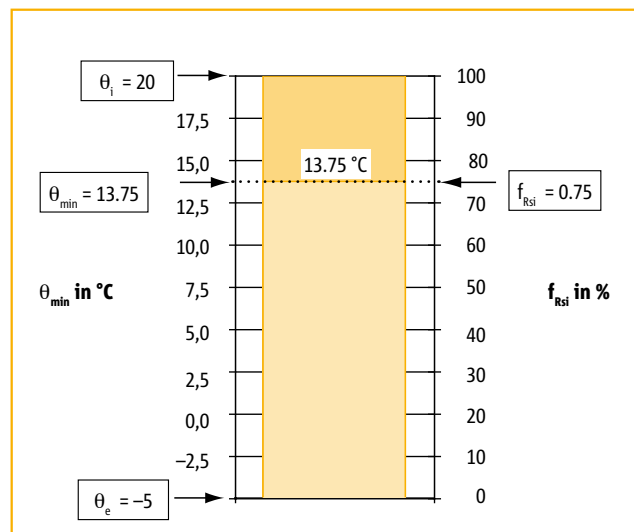

Figure 6: Definition of the f_{Rsi} value

Building physics

Thermal bridges

Requirements in terms of thermal bridges

Requirements relating to minimum surface temperature

In the UK, Building Regulation Approved Document Part L1 (ADL1) and Part L2 (ADL2) cites BRE IP1/06¹⁾ for guidance. The critical temperature factor (f_{CRsi}) is introduced as a means of avoiding mould growth on absorbent surfaces and limiting the risk of surface condensation.

For avoiding mould growth:

Type of building	f_{CRsi}
Dwellings, residential buildings, schools	0.75

For limiting the risk of surface condensation:

Type of building	f_{CRsi}
Offices, retail premises	0.50

f_{CRsi} must be calculated using numerical modelling if the detail does not comply with “Accredited Construction Details”²⁾.

Requirements in terms of thermal losses

In the UK, both ADL1 (Dwellings) and ADL2 (Buildings other than dwellings) require use of whole building models to prove energy compliance, as required by the EU Energy Performance of Buildings Directive.

ADL1 (Dwellings) uses the Government Standard Assessment Procedure SAP 2005 to determine overall carbon dioxide emissions from operating the building. Heat loss through non-repeating thermal bridges (H_{TB}) is calculated using one of two methods:

- ▶ If details of the thermal bridges are not known: $H_{TB} = \psi \times \sum_i A_{exp,i}$ where $\sum_i A_{exp,i}$ is the summed area of exposed elements in m².

If only Accredited Construction Details are used, $\psi = 0.08$. Otherwise, if specific ψ values are not known, a default value of $\psi = 0.15$ applies.

- ▶ If ψ values are known, either through complying with Accredited Construction Details, from manufacturer’s technical data or from the results of numerical modelling: $H_{TB} = \sum_i (L_i \times \psi_i)$ where L_i = length of thermal bridge i in m.

Default values for ψ for junctions in wall constructions are given in Accredited Construction Details and in BRE IP1/06.

If details are as recommended in Accredited Construction Details, the default ψ values quoted in this publication or in BRE IP1/06 can be used.

Otherwise, the ψ values and temperature factors for each type of junction must be obtained from numerical modelling.

¹⁾ “Assessing the effects of thermal bridging at junctions and around openings”, BRE IP1/06, Building Research Establishment, 2006

²⁾ “Accredited construction details for limiting thermal bridging and air leakage”

Building physics

The balcony as a thermal bridge

Non-insulated cantilever building elements

In the case of non-insulated cantilever building elements such as reinforced concrete balconies or steel girders, the combination of geometrical thermal bridge (cooling fin effect of the cantilever) and material-related thermal bridge (penetration of the heat insulation level by reinforced concrete or steel) leads to a great deal of thermal outflow. This makes cantilevers one of the most critical thermal bridges in the building envelope. Considerable thermal losses and a significant reduction in surface temperature are the result of non-insulated cantilevers. This leads to significantly higher heating costs and a very high risk of mould near the cantilever connection area.

Effective thermal insulation using Schöck Isokorb®

Thanks to its thermal and structurally optimised design (minimised reinforcement cross-section combined with optimised load bearing capacity and use of particularly good thermal insulating materials), Schöck Isokorb® is a very effective way of insulating cantilevers.

Schöck Isokorb® for reinforced concrete balconies

The Schöck Isokorb® divides the otherwise continuous reinforced concrete slab near the balcony connection area. The concrete and reinforced concrete, which have good and very good heat-conducting properties respectively, are replaced by Neopor®¹⁾ insulating material and stainless steel, which has very poor heat-conducting properties compared with reinforced concrete, as well as by optimised HTE modules made of high-strength fine concrete in the pressure area (see Table 2). This results in a reduction of thermal conductivity by around 91% e.g. for the Schöck Isokorb® type K50 compared with a traditional reinforced concrete connection (see Fig. 8).

Schöck Isokorb® for steel balconies

Near the steel girder connection point, the use of Schöck Isokorb® replaces the structural steel, which has poor thermal insulation properties, with insulation and stainless steel, the thermal conductivity of which is almost 4 times lower than that of structural steel (see Table 2). This results in a reduction in thermal conductivity by about 94 % for Schöck Isokorb® type KS14 compared with a non-insulated connection (see Fig. 8).

Schöck Isokorb® for steel girder connections in steel construction

Near the steel girder connection point, the highly thermal conductive structural steel is replaced by insulation material or stainless steel, which has very poor thermal conductivity properties compared with structural steel (see Table 2). This results in a reduction of thermal conductivity by around 90 % e.g. for the Schöck Isokorb® type KST 16 compared with a continuous steel girder (see Fig. 8).

	Non-insulated balcony connection	Balcony connection with Schöck Isokorb®	Reduction of thermal conductivity in comparison to non-insulated design by
Materials Balcony connection	Concrete/structural steel $\lambda = 50 \text{ W/m} \times \text{K}$	Stainless steel (material no. 1.4362) $\lambda = 15 \text{ W/m} \times \text{K}$	70 %
		High-strength fine concrete $\lambda = 0.83 \text{ W/m} \times \text{K}$	98 %
	Concrete $\lambda = 1.65 \text{ W/m} \times \text{K}$	Neopor® $\lambda = 0.031 \text{ W/m} \times \text{K}$	98 %

Table 2: Comparison of the thermal conductivity values of different materials in use for balcony connections

In accordance with the BBA certificate no. 05/74277 and OISD Report 0608/4SCH thermal break connection with Schöck Isokorb® types K, KS and KST meet the requirements of ADL1 and ADL2.

¹⁾ Neopor® is a registered brand name of BASF

Building physics

The balcony as a thermal bridge

The equivalent thermal conductivity λ_{eq}

The equivalent thermal conductivity λ_{eq} is the overall thermal conductivity of the Isokorb® insulating element averaged over the contributions of the different surface proportions. Given the same insulating element thickness it is an indicator of the thermal insulation effect of the connection. The smaller λ_{eq} , the higher the thermal insulation of the balcony connection. As the equivalent thermal conductivity takes into account the contributions from the different surface proportions of the materials used, λ_{eq} depends on the load capacity of the Schöck Isokorb®.

In comparison to a connection which is not insulated, the Schöck Isokorb® types K, KS and KST can achieve a reduction in thermal conductivity in the connection area of between up to 90 % and 94 % for the standard load range.

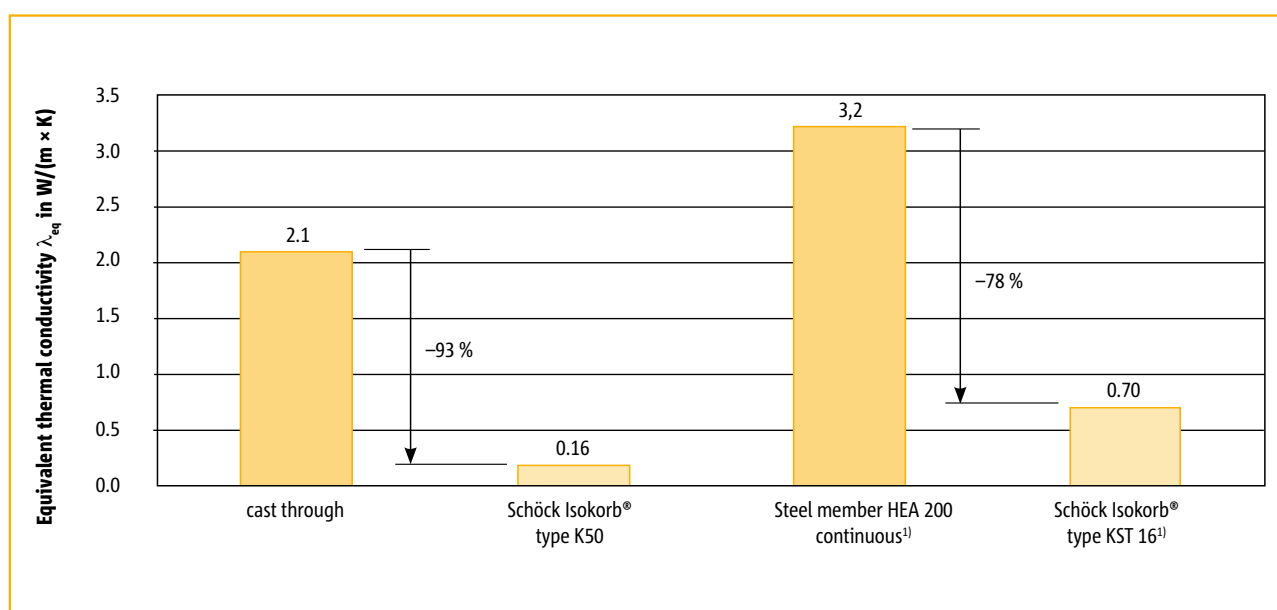

Figure 8: A comparison of equivalent thermal conductivity values λ_{eq} for different balcony slab connections.

Difference between the ψ value and λ_{eq}

The equivalent thermal conductivity λ_{eq} of the insulating element of the Schöck Isokorb® is a measure of the thermal insulation effect of the element, whereas the ψ value indicates the thermal insulation of the balcony as an overall structure. The ψ will always vary according to the design, even if the connection element is unchanged.

Conversely, if the design of the structure is fixed then the ψ value will depend on the equivalent thermal conductivity λ_{eq} of the connection element: the lower λ_{eq} , the lower the ψ value (and the higher the minimum surface temperature).

¹⁾ Reference area: $180 \times 180 \text{ mm}^2$

Building physics

The balcony as a thermal bridge

Thermal bridge characteristic values for balcony connections with Schöck Isokorb®

The thermal bridge characteristic values resulting from a typical construction type and different Isokorb® types are shown in Table 3 below. The underlying construction types are shown in Figures 11a, 12a and 13a. Other construction types which do not match the ones shown here will have different thermal bridge characteristic values.

Schöck Isokorb® type	Equivalent thermal conductivity (3-dim.) λ_{eq} in $W/(m \times K)$	Thermal transmission coefficient ψ in $W/(m \times K)$ (in relation to external dimensions) or χ in W/K	Temperature factor f_{Rsi}
K 50	$\lambda_{eq} = 0.13$	$\psi = 0.20$	$f_{Rsi} = 0.91$
KS 14	$\lambda_{eq} = 0.31^{2)}$	$\chi = 0.097$	$f_{Rsi} = 0.93$
KST 16 ¹⁾	$\lambda_{eq} = 0.70^{3)}$	$\chi = 0.26$	$f_{Rsi} = 0.82$

The characteristic values were determined on the basis of the construction types shown in Figures 11a, 12a and 13a with the following thermal boundary conditions: Heat transfer resistance outside: $R_{si} = 0.04 \text{ Km}^2/\text{W}$, heat transfer resistance inside: $R_{si} = 0.13 \text{ Km}^2/\text{W}$

Table 3: Typical thermal bridge characteristic values that can be achieved with Schöck Isokorb® elements.

¹⁾ Values from Report 060814SCH, Oxford Institute of Sustainable Development, Oxford Brookes University

²⁾ Reference area: $180 \times 180 \text{ mm}^2$

³⁾ Reference area: $250 \times 180 \text{ mm}^2$

Building physics

The balcony as a thermal bridge

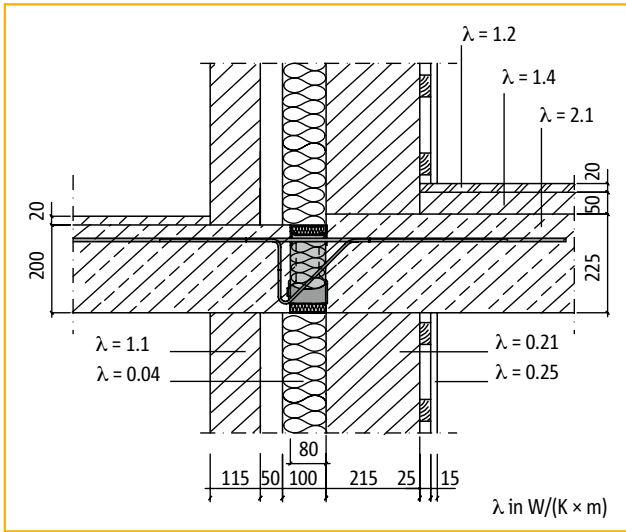

Figure 11a: Balcony slab connection with Schöck Isokorb® type K50-CV30 and a composite thermal insulation system

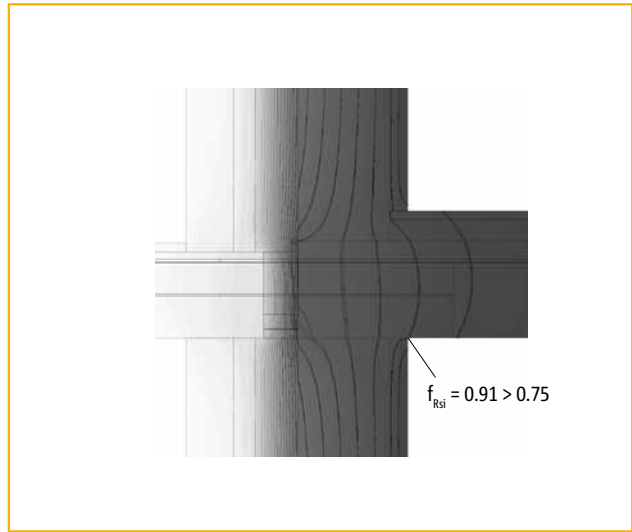

Figure 11b: Isothermals for connection 11a

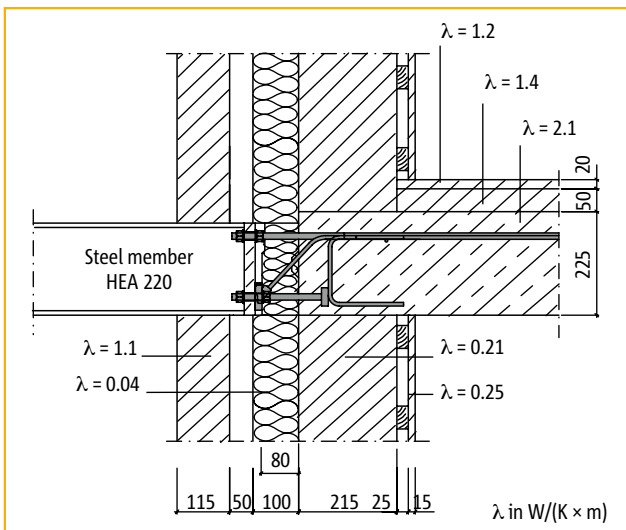

Figure 12a: Connection of steel member HEA 140 with Schöck Isokorb® type KS14 and a composite thermal insulation system

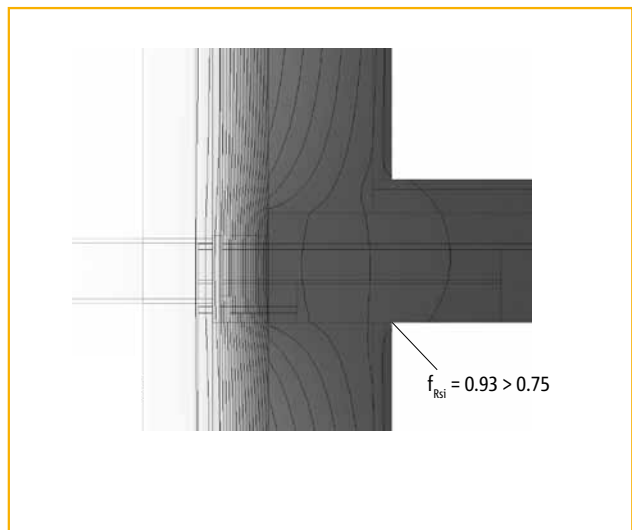

Figure 12b: Isothermals for connection 12a

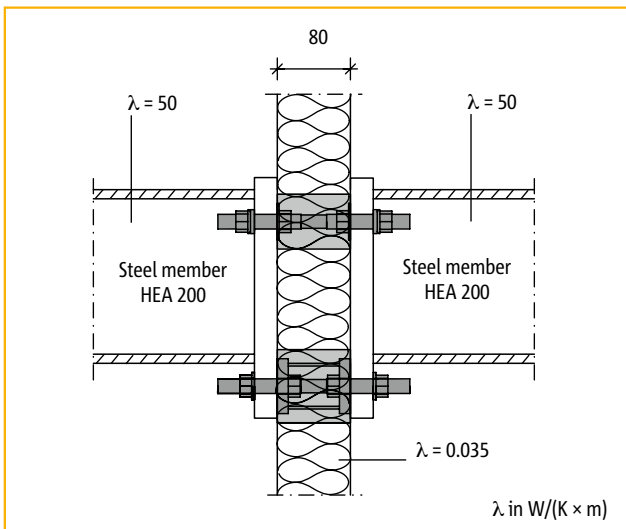

Figure 13a: Connection of steel member HEA 200 with Schöck Isokorb® type KST16

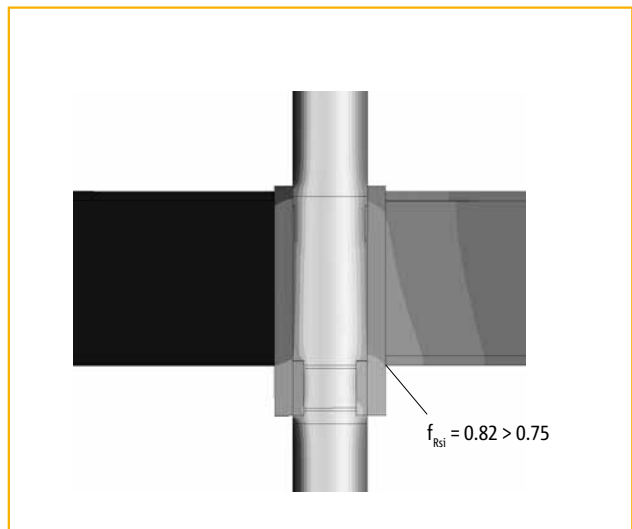

Figure 13b: Isothermals for connection 13a

Building physics

Equivalent thermal conductivity λ_{eq}

λ_{eq} (1-dim.) in W/(m × K) for Schöck Isokorb® type K

Schöck Isokorb® type ¹⁾	Height of Isokorb H [mm]									
	160		170		180		190		200	
	F 0	F 90	F 0	F 90	F 0	F 90	F 0	F 90	F 0	F 90
K10-CV35	0,078	0,099	0,076	0,095	0,073	0,092	0,071	0,089	0,070	0,086
K10-CV35-V8	0,096	0,117	0,093	0,112	0,089	0,107	0,086	0,104	0,084	0,100
K20-CV35	0,098	0,118	0,094	0,113	0,091	0,109	0,088	0,105	0,085	0,101
K20-CV35-V8	0,111	0,131	0,106	0,125	0,102	0,120	0,099	0,116	0,095	0,112
K30-CV35	0,127	0,148	0,122	0,141	0,117	0,135	0,112	0,130	0,108	0,125
K30-CV35-V8	0,144	0,165	0,138	0,157	0,132	0,150	0,127	0,144	0,122	0,138
K30-CV35-V10	0,163	0,184	0,156	0,175	0,149	0,167	0,143	0,160	0,137	0,154
K40-CV35	0,136	0,156	0,130	0,149	0,124	0,142	0,120	0,137	0,115	0,132
K40-CV35-V8	0,153	0,173	0,146	0,165	0,139	0,158	0,134	0,151	0,129	0,145
K40-CV35-V10	0,167	0,187	0,159	0,178	0,152	0,170	0,146	0,163	0,140	0,157
K40-CV35-VV	0,177	0,197	0,168	0,187	0,161	0,179	0,154	0,171	0,148	0,164
K50-CV35	0,156	0,177	0,149	0,168	0,143	0,161	0,137	0,154	0,132	0,148
K50-CV35-V8	0,173	0,194	0,165	0,184	0,158	0,176	0,151	0,168	0,145	0,162
K50-CV35-V10	0,183	0,203	0,174	0,193	0,166	0,184	0,159	0,176	0,153	0,169
K50-CV35-VV	0,202	0,222	0,192	0,211	0,183	0,201	0,175	0,193	0,168	0,185
K60-CV35	0,224	0,244	0,213	0,232	0,203	0,221	0,194	0,211	0,186	0,202
K60-CV35-V8	0,224	0,244	0,213	0,232	0,203	0,221	0,194	0,211	0,186	0,202
K60-CV35-V10	0,233	0,254	0,222	0,241	0,211	0,229	0,202	0,219	0,193	0,210
K60-CV35-VV	0,262	0,282	0,248	0,268	0,236	0,255	0,226	0,243	0,216	0,233
K70-CV35	0,241	0,261	0,229	0,248	0,218	0,236	0,208	0,225	0,199	0,216
K70-CV35-V8	0,241	0,261	0,229	0,248	0,218	0,236	0,208	0,225	0,199	0,216
K70-CV35-V10	0,245	0,266	0,233	0,252	0,222	0,240	0,212	0,229	0,203	0,220
K70-CV35-VV	0,269	0,290	0,255	0,275	0,243	0,261	0,232	0,249	0,222	0,238
K80-CV35-V8	0,250	0,271	0,238	0,257	0,226	0,244	0,216	0,233	0,207	0,223
K80-CV35-V10	0,250	0,271	0,238	0,257	0,226	0,244	0,216	0,233	0,207	0,223
K80-CV35-VV	0,269	0,290	0,255	0,275	0,243	0,261	0,232	0,249	0,222	0,238
K90-CV35-V8	0,263	0,283	0,249	0,268	0,237	0,255	0,226	0,244	0,217	0,233
K90-CV35-V10	0,263	0,283	0,249	0,268	0,237	0,255	0,226	0,244	0,217	0,233
K90-CV35-VV	0,281	0,302	0,267	0,286	0,254	0,272	0,242	0,260	0,232	0,248
K100-CV35-V8	0,270	0,290	0,256	0,275	0,244	0,262	0,233	0,250	0,223	0,239
K100-CV35-V10	0,275	0,295	0,260	0,280	0,248	0,266	0,237	0,254	0,226	0,243
K100-CV35-VV	0,293	0,314	0,278	0,297	0,265	0,283	0,252	0,270	0,242	0,258

Further λ_{eq} values for other types can be found at: www.schoeck.co.uk/en_gb/download/thermal-values-384

¹⁾ same λ_{eq} values for CV30 and CV50, CV50 available from H = 180 mm

Building physics

Equivalent thermal conductivity λ_{eq}

λ_{eq} (1-dim.) in W/(m × K) for Schöck Isokorb® type K

Schöck Isokorb® type ¹⁾	Height of Isokorb H [mm]									
	210		220		230		240		250	
	F 0	F 90	F 0	F 90	F 0	F 90	F 0	F 90	F 0	F 90
K10-CV35	0,068	0,083	0,066	0,081	0,065	0,079	0,064	0,077	0,062	0,076
K10-CV35-V8	0,081	0,097	0,079	0,094	0,077	0,091	0,075	0,089	0,074	0,087
K20-CV35	0,083	0,098	0,080	0,095	0,078	0,093	0,076	0,090	0,075	0,088
K20-CV35-V8	0,092	0,108	0,090	0,105	0,087	0,102	0,085	0,099	0,083	0,096
K30-CV35	0,105	0,120	0,102	0,117	0,099	0,113	0,096	0,110	0,094	0,107
K30-CV35-V8	0,118	0,133	0,114	0,129	0,111	0,125	0,107	0,121	0,104	0,118
K30-CV35-V10	0,132	0,148	0,128	0,143	0,124	0,138	0,120	0,134	0,117	0,130
K40-CV35	0,111	0,127	0,108	0,123	0,105	0,119	0,102	0,115	0,099	0,112
K40-CV35-V8	0,124	0,140	0,120	0,135	0,116	0,131	0,113	0,127	0,110	0,123
K40-CV35-V10	0,135	0,151	0,131	0,145	0,126	0,141	0,123	0,136	0,119	0,132
K40-CV35-VV	0,143	0,158	0,138	0,153	0,133	0,147	0,129	0,143	0,125	0,138
K50-CV35	0,127	0,143	0,123	0,138	0,119	0,133	0,115	0,129	0,112	0,125
K50-CV35-V8	0,140	0,156	0,135	0,150	0,131	0,145	0,127	0,140	0,123	0,136
K50-CV35-V10	0,147	0,163	0,142	0,157	0,137	0,152	0,133	0,147	0,129	0,142
K50-CV35-VV	0,162	0,178	0,156	0,171	0,151	0,165	0,146	0,160	0,141	0,155
K60-CV35	0,179	0,194	0,172	0,187	0,166	0,180	0,161	0,174	0,156	0,169
K60-CV35-V8	0,179	0,194	0,172	0,187	0,166	0,180	0,161	0,174	0,156	0,169
K60-CV35-V10	0,186	0,201	0,179	0,194	0,173	0,187	0,167	0,180	0,162	0,175
K60-CV35-VV	0,208	0,223	0,200	0,215	0,192	0,207	0,186	0,199	0,180	0,193
K70-CV35	0,192	0,207	0,184	0,199	0,178	0,192	0,172	0,185	0,166	0,179
K70-CV35-V8	0,192	0,207	0,184	0,199	0,178	0,192	0,172	0,185	0,166	0,179
K70-CV35-V10	0,195	0,211	0,188	0,203	0,181	0,195	0,175	0,189	0,169	0,182
K70-CV35-VV	0,213	0,229	0,205	0,220	0,198	0,212	0,191	0,204	0,184	0,198
K80-CV35-V8	0,199	0,214	0,191	0,206	0,184	0,199	0,178	0,192	0,172	0,186
K80-CV35-V10	0,199	0,214	0,191	0,206	0,184	0,199	0,178	0,192	0,172	0,186
K80-CV35-VV	0,213	0,229	0,205	0,220	0,198	0,212	0,191	0,204	0,184	0,198
K90-CV35-V8	0,208	0,224	0,200	0,215	0,193	0,207	0,186	0,200	0,180	0,193
K90-CV35-V10	0,208	0,224	0,200	0,215	0,193	0,207	0,186	0,200	0,180	0,193
K90-CV35-VV	0,222	0,238	0,214	0,229	0,206	0,220	0,199	0,213	0,192	0,205
K100-CV35-V8	0,214	0,229	0,206	0,220	0,198	0,212	0,191	0,205	0,185	0,198
K100-CV35-V10	0,217	0,233	0,209	0,224	0,201	0,216	0,194	0,208	0,188	0,201
K100-CV35-VV	0,232	0,247	0,223	0,238	0,214	0,229	0,207	0,221	0,200	0,213

¹⁾ same λ_{eq} values for CV30 and CV50, CV50 available from H = 180 mm

Schöck Isokorb®

Fire resistance classes

The definitive regulations regarding fire protection are laid out in the local building regulations, such as Department of the Environment, Transport and the Regions: The Building Regulations 1991, Approved Document B, Fire safety DETR 2000, BS 5588 Fire precautions in the design, construction and use of buildings, BS 7974 Application of the safety engineering principles to the design of buildings, Irish Building Regulations 2006 from the Department of the Environment, Heritage and local Government: Technical Guidance Document B, Fire safety, BS 8110-1, BS 8110-2, and National Annex to BS EN 1992-1-2:2004 Part 1-2: General rules - Structural fire design.

Fire resistance class F 90

For cases with special fire safety requirements in terms of the fire resistance class of balconies, Schöck Isokorb® can also be supplied for fire resistance class F 90¹⁾. Thereto suitable F 90 materials are attached at the factory to the upper side and the underside of the Schöck Isokorb® (see illustration). However, in order for the balcony connection area to be classified as F 90-compliant, it is a further requirement that the balcony slab and the inner slab of the intermediate floor also satisfy the requirements in terms of fire resistance class F 90 according to the local building regulations.

Integrated fire protection strips made of materials which form an insulating layer, or the fire safety boards on the upper side of the Schöck Isokorb® which protrude by 10 mm, guarantee that the joints which open up under the effects of a fire are effectively sealed, so that no hot gases can reach the reinforcing bars of the Schöck Isokorb® (see illustration). This arrangement is essential if the design is to be classified as compliant with fire resistance class F 90 even without additional onsite fire safety measures (e.g. mineral-based coating or finish).

Note: When fire resistance has been specified, some Schöck Isokorbs may be delivered to site with an F 120 rating (only for the types K, Q and Q+Q with HTE modules). These Isokorbs not only achieve a fire resistance class of F 90 according to the BBA Approval No. 05/4277, but also F 120 or R 120 (according to the CSTB Rating Report No. RS06 167).

Types with integrated intumescent strips: K, K20-corner

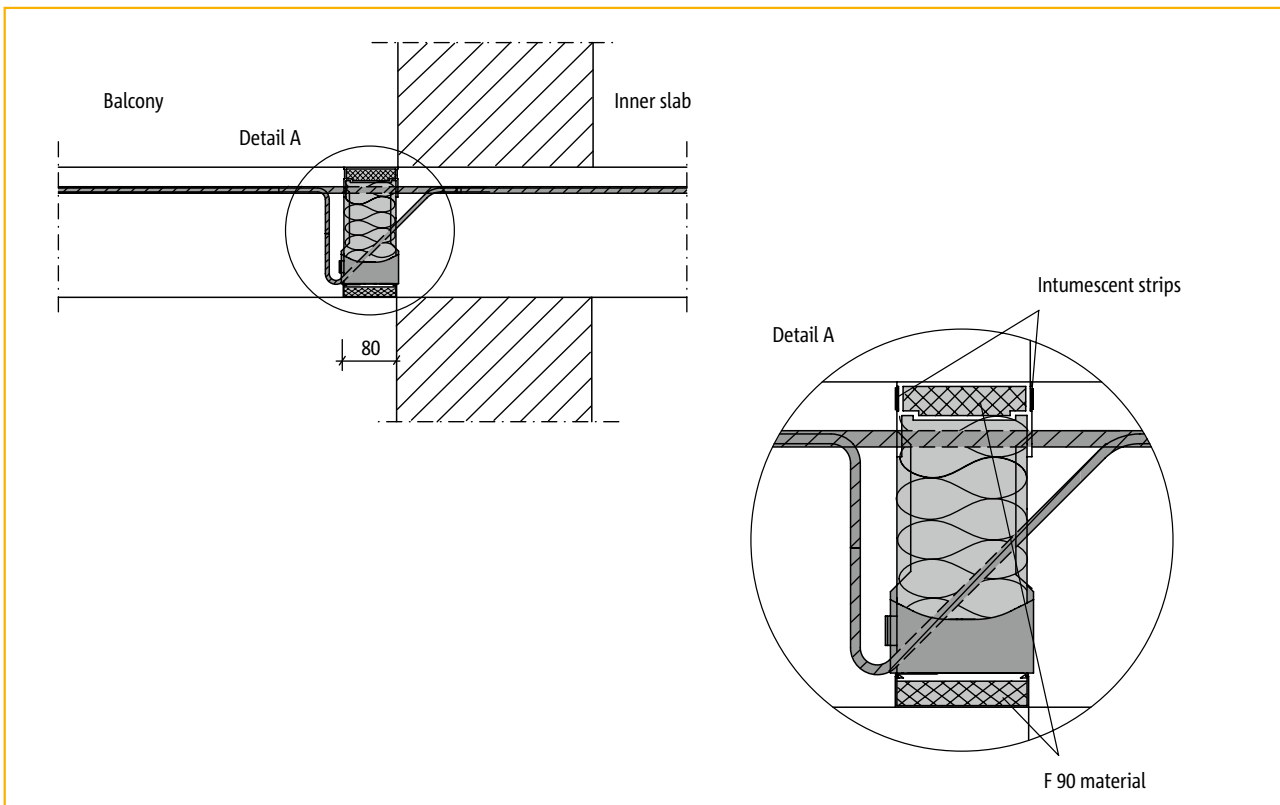

e.g.: Schöck Isokorb® type K50-CV35-H180-F90

¹⁾ Advisory opinion of the iBMB Institute for Building Materials, Solid Construction and Fire Protection at the Technical University of Brunswick

Schöck Isokorb®

Notes/Fire resistance class F 90 or F 120

Types with integrated F90 material: K-HV, K-BH, K-WO, K-WU, K30-corner, K50-corner, Q, Q+Q, QP, QP+QP, V, HP, D, O, F, S, W

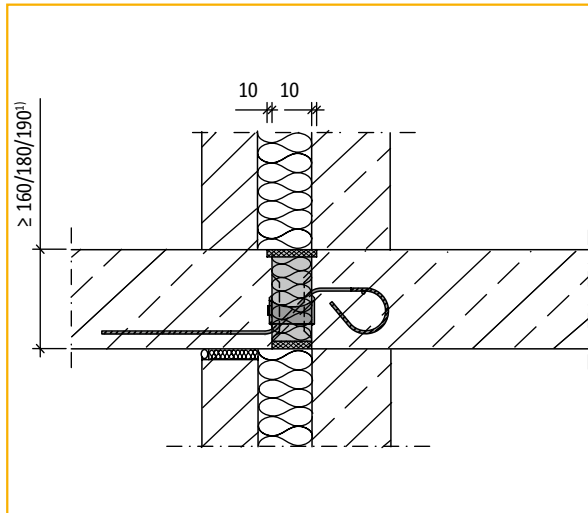

e.g.: Schöck Isokorb® type Q10-H180-F120

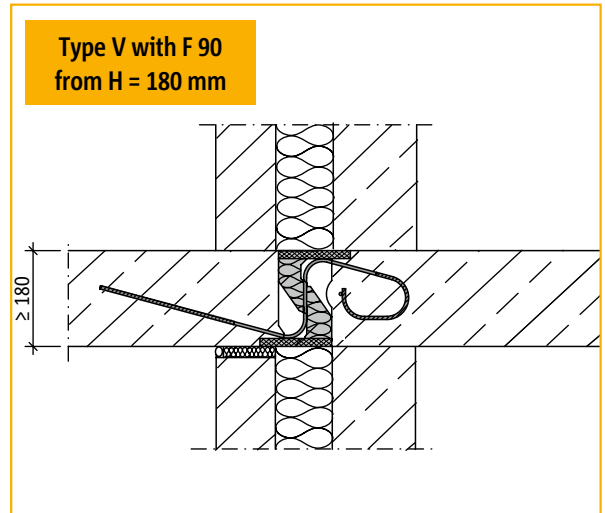

e.g.: Schöck Isokorb® type V6/4-H180-F90

Notes

- ▶ Components which are adjacent to the Schöck Isokorb® element must not be connected to the lower Isokorb® fire protection plate by using bolts, screws, nails or similar.
- ▶ If the F 90 or F 120 version of the Schöck Isokorb® is partially installed in space-enclosing walls (e.g. of type W) or inner slabs (e.g. of type K), the insulation which is to be added must be provided on-site using mineral wool with a melting point > 1000 °C (e.g. Rockwool).

¹⁾ min H for F 90 acc. to pages 75 - 76 depending on the selected load range

Schöck Isokorb® type D

Page 97



for balcony slabs which extend into ceiling panels.



Schöck Isokorb® type K-corner

Page 45

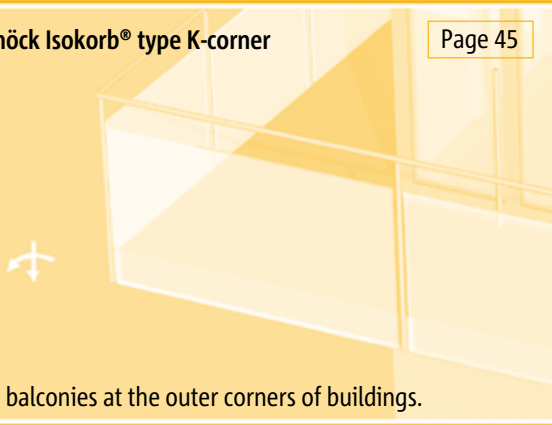

for balconies at the outer corners of buildings.



Schöck Isokorb® type Q

Page 67



for the connection of supported balconies.



Schöck Isokorb® type K

Page 29



for the insulation of cantilever balconies.

Schöck Isokorb® type KF

on request



for the insulation of semi pre-cast cantilever balconies.

Schöck Isokorb® type K-HV

Page 55



for the insulation of step down cantilever balconies.

Schöck Isokorb® type K-BH

Page 55



for the insulation of step up cantilever balconies.

Schöck Isokorb® type K-WO

Page 55



for the insulation of cantilever balconies connected to a wall (rebars bent upwards).

Schöck Isokorb® type K-WU

Page 55



for the insulation of cantilever balconies connected to a wall (rebars bent downwards).





Information about further solutions can be obtained
from our Technical Design Department.
Tel.: 0845 241 3390



Schöck Isokorb® type O

Page 105



for the insulation of corbels as support for frost-resistant masonry.



Schöck Isokorb®
type A

Page 117



for insulation between RC upstand and slab.

Schöck Isokorb®
type F

Page 111



for insulation between RC upstand balustrade and face of slab.



Schöck Isokorb® type S

Page 123



for the insulation of cantilever beams.

Schöck Isokorb®
type W

Page 129



for the insulation of fin walls.

Schöck Isokorb®

Basic information

With the publication of this new and comprehensive Technical Information all technical specifications, structural analysis and figures about the Schöck Isokorb® systems (except for type KSH and QSH) are based on British Standards, especially on Eurocode 2 with UK National Annex. On this basis a BBA Approval and several certificates established by United Kingdom experts have been obtained (see page 2).

The new range of load-bearing thermal insulation components for Isokorb® units type K (previously designed as type KX) enables the structural engineer to choose amongst various dimensions of concrete cover. The tension rods of type K units and of type D units are available with $c_{nom} = 30$ mm, or 35 mm, or 50 mm. Therefore the selection of the concrete cover has to be considered as a basic part of the type designation (e.g. type K50-CV35 signifies a concrete cover $c_{nom} = 35$ mm for the Schöck Isokorb® tension rods).

To avoid confusion with the correct and complete designations for type K and type D the load range codes have been changed (see comparison of the previous designations to the new ones on page 26 and 27).

Concrete cover

Assuming exposure grades of XC3 and XC4 with XF1, the nominal cover to reinforcement called for by BS 8500 and UK National Annex to Eurocode 2 is $25 \text{ mm} + \Delta c_{dev}$ for a grade C32/40 concrete. Additionally assuming the standard value of 10 mm for Δc_{dev} , this corresponds to the 35 mm nominal cover to which the standard Isokorb units (CV35) are manufactured.

The range of units with 30 mm nominal cover (CV30) will be suitable where a grade C32/40 mix is used in conjunction with a Δc_{dev} of 5 mm, or C40/50 with a Δc_{dev} of 10 mm.

The range of units with 50 mm nominal cover (CV50) will be suitable e.g. where tension rods have to be in the second layer, because of a balcony with “inside corner layout” (see plan view at bottom of page 38).

Concrete grades

For the relevant exposure grades XC3 and XC4 with XF1, the minimum grade of concrete employed for compliance with BS 8500 and UK National Annex will normally be C32/40. Because of cover considerations (see above), the use of grade C25/30 would only be feasible where the appointment of an accredited frame contractor allows the use of a reduced Δc_{dev} of 5 mm.

For compliance with BBA Approval, Agreement Certificate No 05/4277, the minimum grade of concrete used in the supporting floor must be at least C25/30.

Therefore in the Isokorb® calculations, the assumed grade for concrete cast in areas adjoining the units is taken as C25/30, except for type K100. With this type the minimum concrete must be at least C32/40 for the balcony and for the inner slab.

Schöck Isokorb®

Concrete cover/Concrete grades

To meet durability requirements, depending on conditions of exposure, concrete cover and concrete grades should be chosen according to local regulations, such as BS 8500 or EC2 and its UK National Annex.

Most relevant exposure grades		part of type designation	
XC3, XF1	- minimum concrete grade \geq C32/40	→ $c_{nom} = 35$ mm	→ CV35
XC4, XF1	- minimum concrete grade \geq C32/40	→ $c_{nom} = 35$ mm	→ CV35
	- when reduced Δc_{dev} of 5 mm allowed	→ $c_{nom} = 30$ mm	→ CV30
XD1, XS1	- minimum concrete grade \geq C32/40	→ $c_{nom} = 50$ mm	→ CV50

Example

- Choice:
- exposure grades XC4, XF for balcony
 - minimum concrete grade C32/40
 - concrete cover Schöck Isokorb® CV35

 - exposure grade XC1 for inner slab
 - minimum concrete grade C25/30 (acc. to approval) is critical in terms of Schöck Isokorb® calculation

Notes

- ▶ Type K, K-corner, K-HV, K-BH, K-WO and K-WU: CV30, CV35 and CV50 refers to the concrete cover of the tensile rebars.
- ▶ Type D: CV30 and CV35 refers to the concrete cover of the upper tensile rebars. The concrete cover of the lower tensile rebars is 30 mm in both cases (normally less exposure than the upper surface of balcony).
- ▶ Type D: CV50 refers to the concrete cover of the upper and the lower tensile rebars.
- ▶ Type Q and Q+Q: The concrete cover of the Isokorb-rebars at the lower balcony surface is 30 mm in general.
- ▶ Type QP, QP+QP and QPZ: The concrete cover of the Isokorb-rebars at the lower balcony surface is 40 mm in general.
- ▶ In case of special requests referring the concrete cover please ask our design support services.

Order reference example

(to be issued in structural design, construction drawings, submission, order), e.g. for H = 180 mm

Schöck Isokorb® type **K50-CV35-V8-H180-F90**

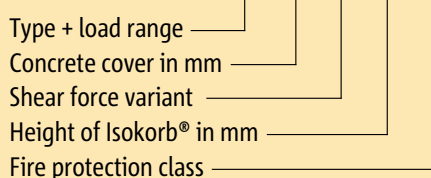

Schöck Isokorb®

Structural design and calculation program

The new Isokorb® calculation software has been developed for the quick and easy calculation of balcony connections with thermal breaks using the Isokorb® types K, K-corner, KF, Q and D for the most common balcony geometries and bearing conditions. The calculations are based on DIN 1045-1 and the general building authority approval issued by the German Institute for Construction Technology, DIBt. The following balcony types can be calculated:

- ▶ Cantilever balcony
- ▶ Supported balcony
- ▶ Loggia balcony (restraint-free connection)
- ▶ Inner-corner balcony (free cantilevered)
- ▶ Inner-corner balcony (supported)
- ▶ Outer-corner balcony (free cantilevered)
- ▶ Outer-corner balcony (supported)

Most details can be entered both in the input mask or directly in the diagram. Input masks that are not constantly required can be hidden completely to give users a better overview of the interface. The software calculates the member forces in the connection joint with the aid of an integrated FEM module. The software suggests suitable Isokorb elements to match these member forces and the given geometric circumstances.

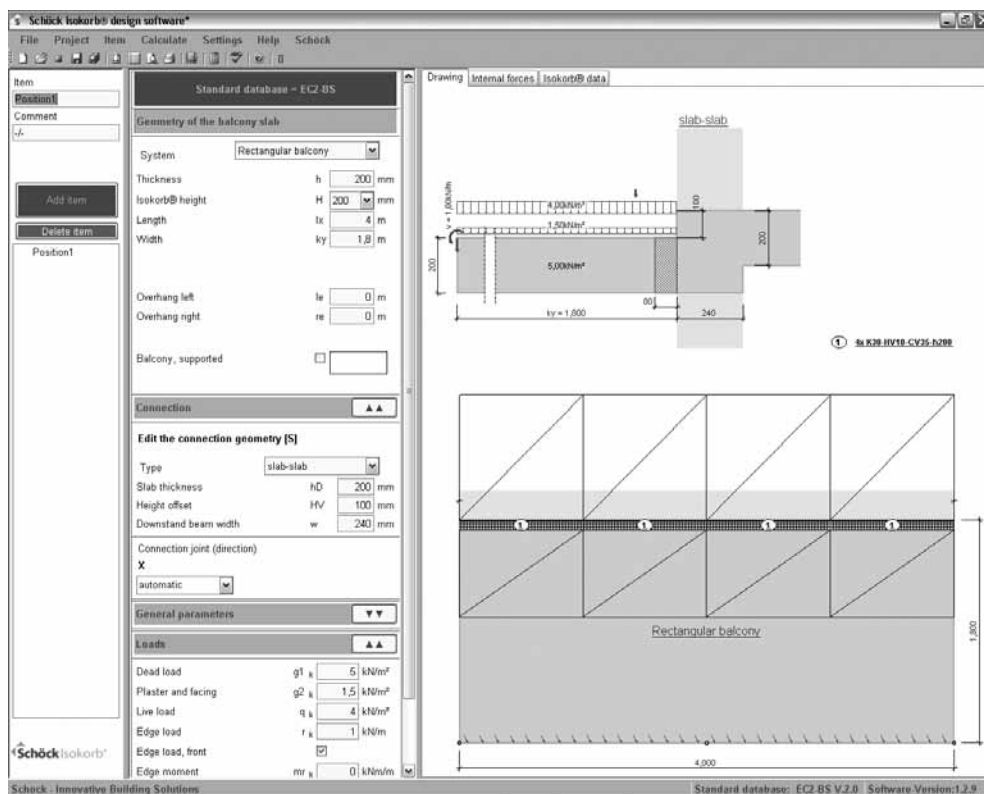

The results can be shown numerically and/or in diagram form. An installation plan for the Isokorb elements required is generated, including the respective positioning. All the balcony positions can be recorded in a project file. Further functions of the new Isokorb® calculation software:

- ▶ Parts list
- ▶ Integrated product finder (independent of the technical information)
- ▶ Important planning instructions for the individual Isokorb® types (installation instructions, on-site connection reinforcements etc.)
- ▶ Choice of output type (compact or summarised)

The Isokorb® calculation software is available as a free download and can also be requested on CD-ROM. It runs under MS-Windows with MS-Framework 3.5.

Schöck Isokorb®

Structural design and calculation program

Please ask about our planning CD for optimised and economic calculation of Schöck Isokorb® elements.

Contents:

- ▶ Calculation software Schöck Isokorb® type K, type Q, type D
- ▶ Calculation software Schöck Isokorb® type KST
- ▶ Calculation software Schöck BOLE®
- ▶ Calculation software Schöck Dorn SLD plus
- ▶ CAD files in dxf/dwg format
- ▶ Acrobat Reader
- ▶ Brief information about the programs
- ▶ General building authority approvals
- ▶ Technical information

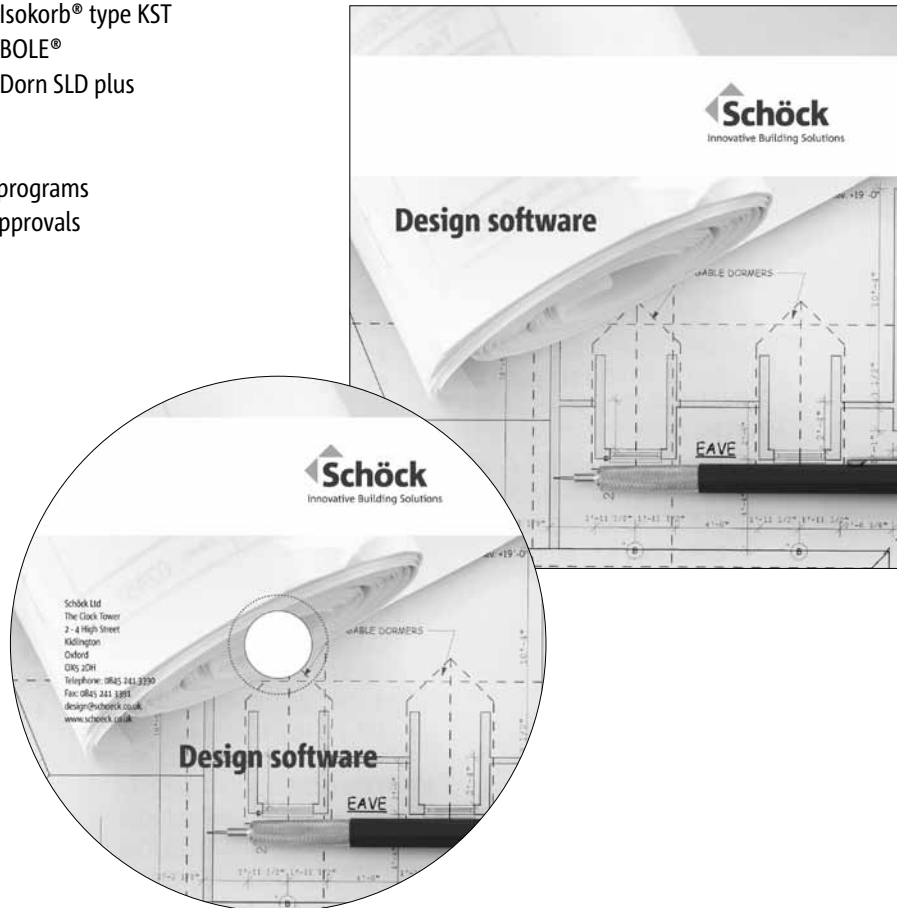

Reinforced concrete-to-reinforced concrete

Downloads and queries

Tel.: 0845 241 3390

Fax: 0845 241 3391

E-mail: design@schoeck.co.uk

Web: www.schoeck.co.uk

Schöck Isokorb®

FEM guidelines

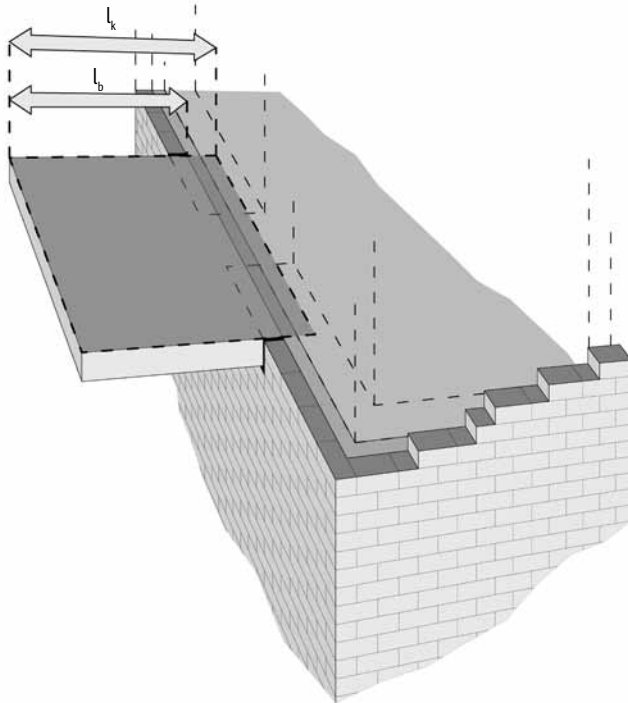

To get the most realistic results for the alignment and loadtransfer of our Schöck Isokorb®, we recommend the following steps to be considered using FEM in conjunction with the Schöck Isokorb®:

- l_k = system cantilever length used for the Isokorb® calculation
- l_b = geometrical cantilever length from the Schöck Isokorb® (insulation body)

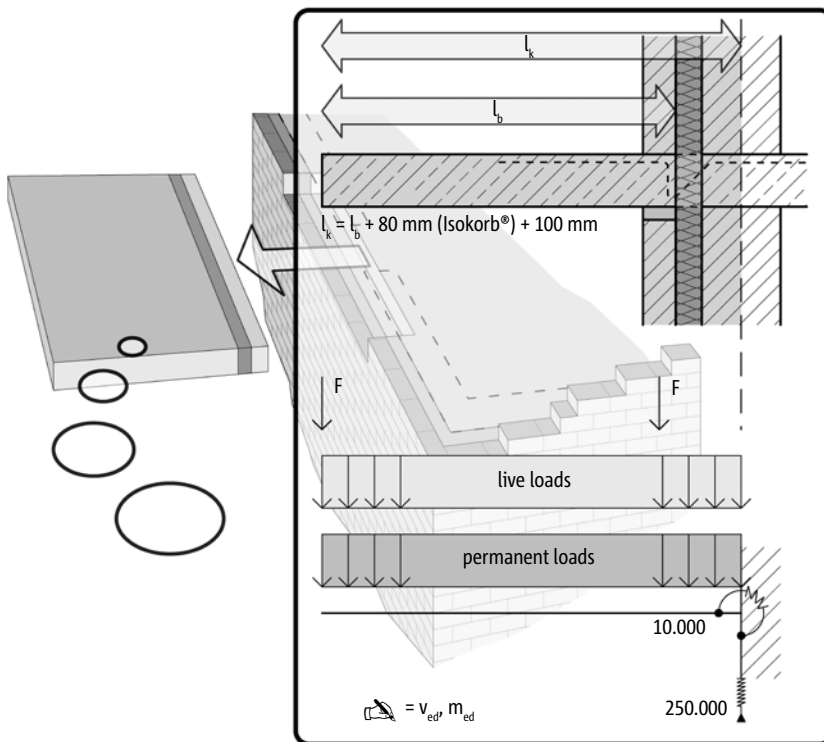

- ▶ Separate the balcony from the internal structure
- ▶ Locate the Isokorb®-“bearing“ in areas where you would like to transfer loads into the internal structure.
- ▶ To simulate the Schöck Isokorb® performance please use the following spring stiffness: 10 000 kNm/rad/m (rotation), 250 000 kN/m² (vertical).
- ▶ The stiffness of the structure in the support area (slab/wall) should be taken as almost infinitely stiff.
- ▶ Calculate the internal forces for the balcony connection with Schöck Isokorb®.

Schöck Isokorb®

FEM guidelines

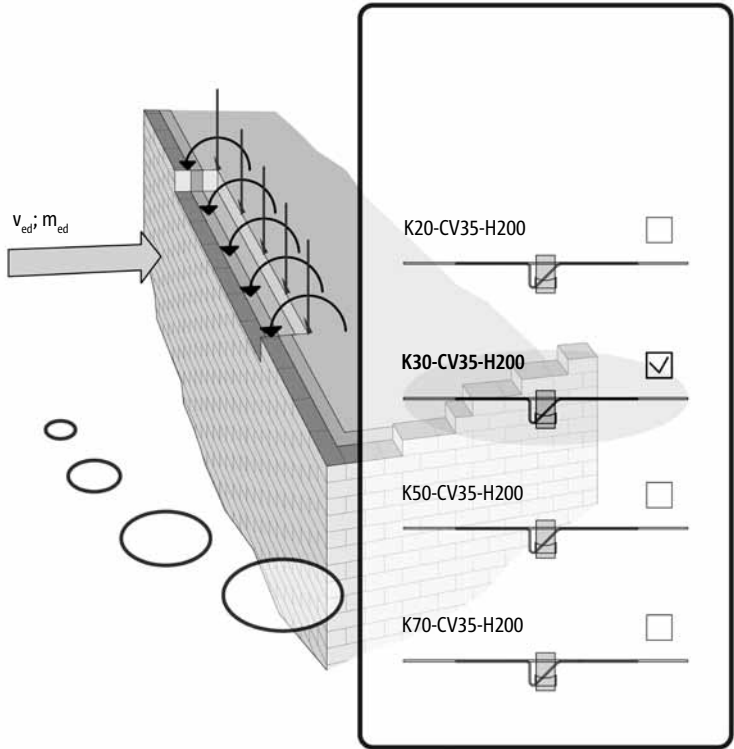

The diagram illustrates a Schöck Isokorb connection between a concrete slab and a supporting structure. It shows the application of design shear force v_{ed} and design bending moment m_{ed} at the connection. Below the diagram is a table listing four different Isokorb types with their corresponding selection status:

K20-CV35-H200	<input type="checkbox"/>
K30-CV35-H200	<input checked="" type="checkbox"/>
K50-CV35-H200	<input type="checkbox"/>
K70-CV35-H200	<input type="checkbox"/>

- ▶ The internal forces may only be calculated by linear elastic methods.
- ▶ Select, according to the determined acting forces, the type and load capacity of the Schöck Isokorb®.
- ▶ The calculated values, m_{ed} and v_{ed} then to be applied on the outer supporting structure of the building.
- ▶ With large differences in stiffnesses between the support and connected element, the variance in moment and shear forces along leaner edge of the connection should be taken into consideration.
- ▶ Important for the modelling and design: the Schöck Isokorb® can not take torsional loads.

Note

- ▶ Our Schöck Isokorb®, if it is a type to fix cantilevered balconies, is able to bear bending moments, but no torsional moments. Therefore, concerning FEM-modelling of the entire structure, the balconies are not to be modelled as a plate which is fixed monolithic to the internal structure. Instead of that its stress resultants have to be considered as external line loads (bending moments and shear forces) towards the edges of the RC floor slabs.

Schöck Isokorb®

Materials for concrete-to-concrete applications

Schöck Isokorb®

Reinforcing steel	BSt 500 S acc. to EC 2 National Annex
Structural steel	S 235 JR
Stainless steel	Ribbed reinforcing steel BSt 500 NR: material no. 1.4362 or no. 1.4571 Tensile rebars: material no. 1.4362 ($f_{yk} = 700 \text{ N/mm}^2$) Plain rebars: material no. 1.4571, hardening level S 460,
Pressure bearings	HTE module (pressure bearings made of microfibre-reinforced high-performance fine concrete) PE-HD plastic jackets
Insulating material	Neopor® ¹⁾ hard foam ($\lambda = 0.031 \text{ W/(m} \times \text{K)}$), Polystyrene hard foam, $\lambda = 0.035 \text{ W/(m} \times \text{K)}$
Fire protection boards	Lightweight building boards, materials class A1, cement-bound fire safety boards, mineral wool: $\rho \geq 150 \text{ kg/m}^3$, Melting point $T \geq 1000 \text{ }^\circ\text{C}$ with integrated fire protection strips

Connecting components

Reinforcing steel	B500A, B500B or B500C acc. to BS 4449 or BS 4483
Concrete	Standard concrete acc. to BS EN 206-1 with a dry apparent density of 2000 kg/m^3 to 2600 kg/m^3 (lightweight concrete is not permissible) Concrete grade for outside components: At least C32/40, plus according to the environmental classification acc. to BS 8500 or acc. to EC 2 National Annex Concrete grade for inside components: At least C25/30, plus according to the environmental classification acc. to BS 8500 or acc. to EC 2 National Annex

Note concerning the bending of reinforcement steel

The production of Schöck Isokorb® is carefully monitored at the factory to ensure that all bars are bent in accordance to our technical approval and EC2.

Caution: If original Schöck Isokorb® rebars bent on site, or bent and bent back, the monitoring of compliance with regards the required conditions (technical approval, EC2) of such actions is not the responsibility of Schöck GmbH. Our warranty will be voided in such cases.

¹⁾ Neopor® is a registered brand name of BASF

Schöck Isokorb® type K

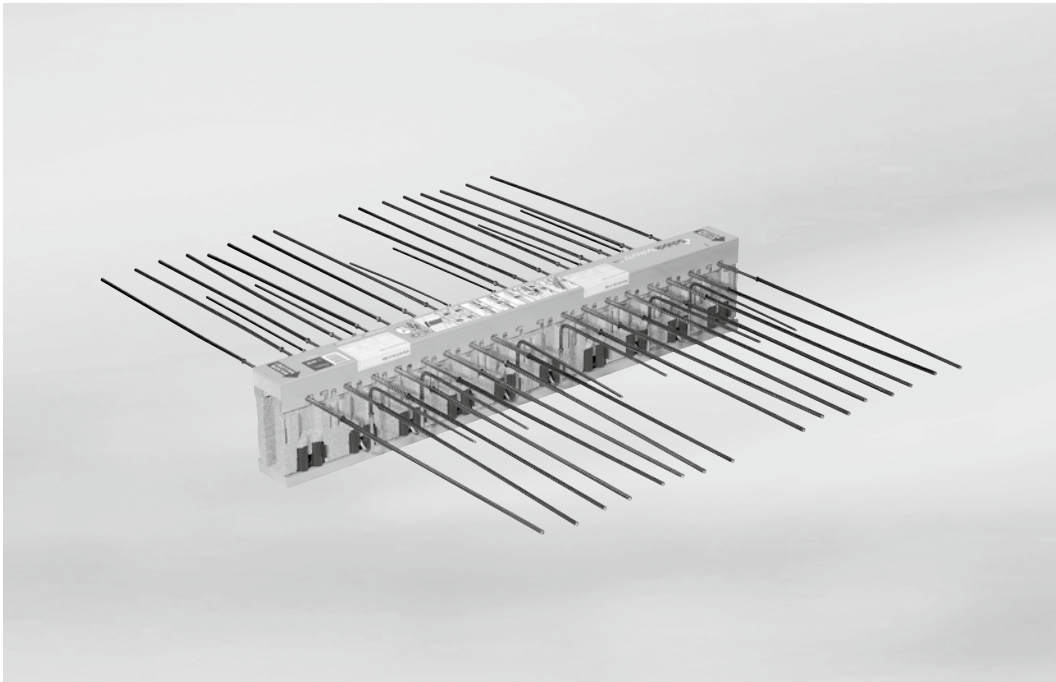

Schöck Isokorb® type K

HTE

K

Reinforced concrete-to-reinforced concrete

Contents	Page
Examples of element arrangements/Cross-sections	30
Plan views	31
Product variants/Designations	32
Product description	33
Capacity tables	34 - 35
Installation in conjunction with precast planks	36
Expansion joint/Example showing joint detail	37
Lap splice design	38 - 39
Example calculation/Notes	40
Deflection/Flexural slenderness	41
Method statement	42
Check list	43
Fire resistance	16 - 17

Schöck Isokorb® type K

Examples of element arrangements/Cross-sections

TE

K

Reinforced concrete-to-reinforced concrete

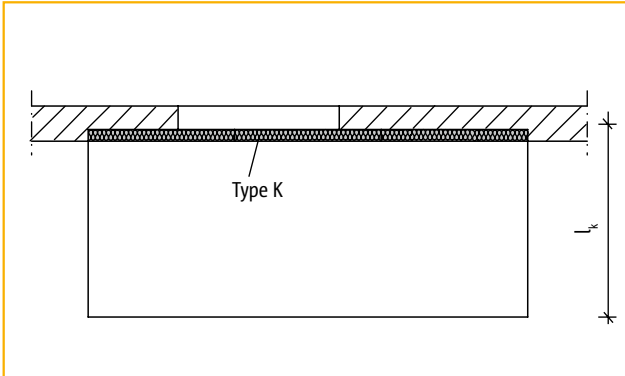

Figure 1: Free cantilever balcony

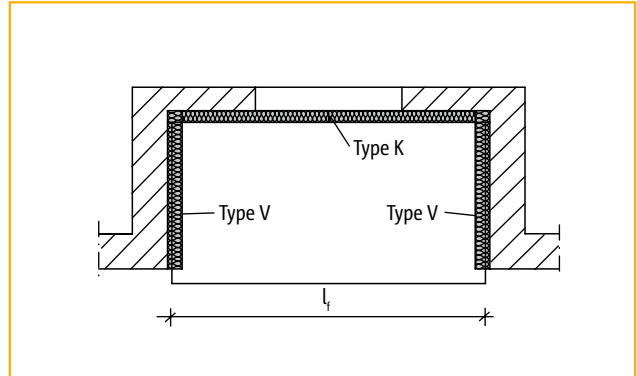

Figure 2: Balcony supported on three sides

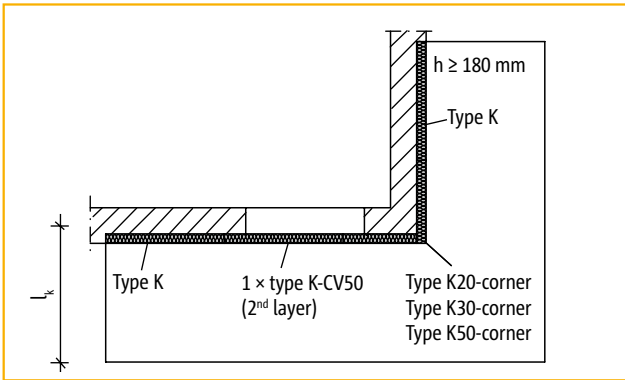

Figure 3: Balcony on an outside corner

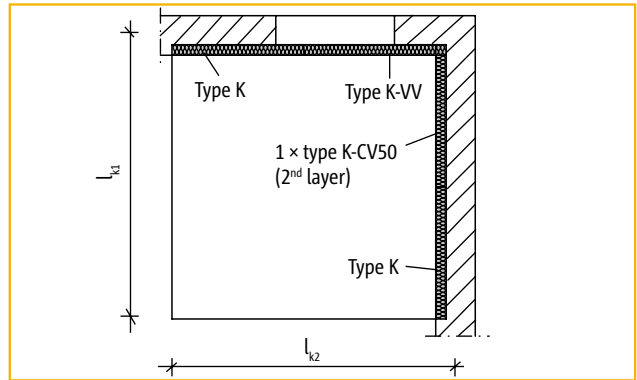

Figure 4: Balcony supported on two sides

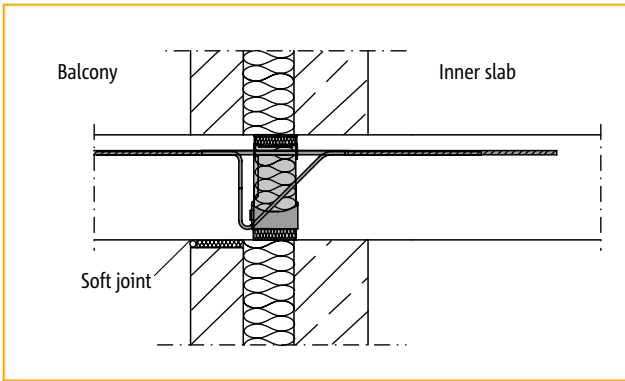

Figure 5: Cavity wall with a balcony at inner slab level

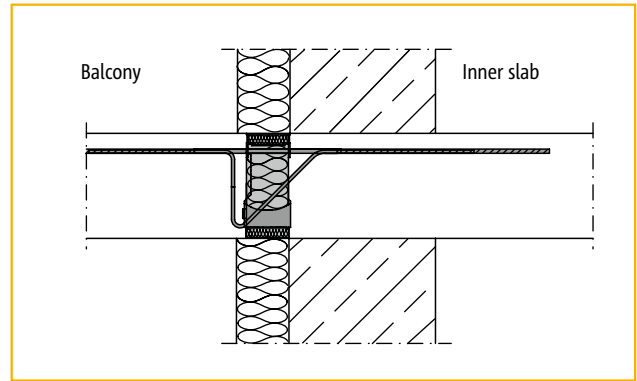

Figure 6: Brickwork with external insulation and a balcony at inner slab level

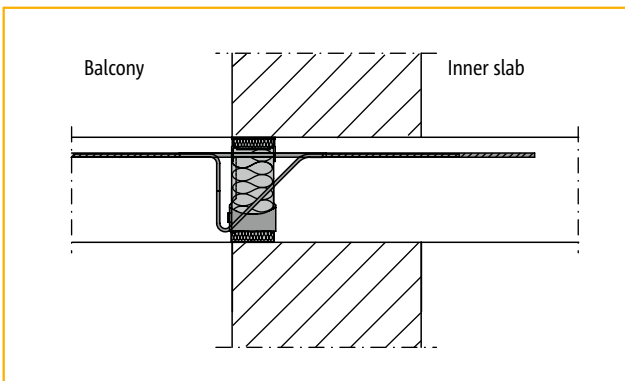

Figure 7: Single-leaf brickwork with a balcony at inner slab level

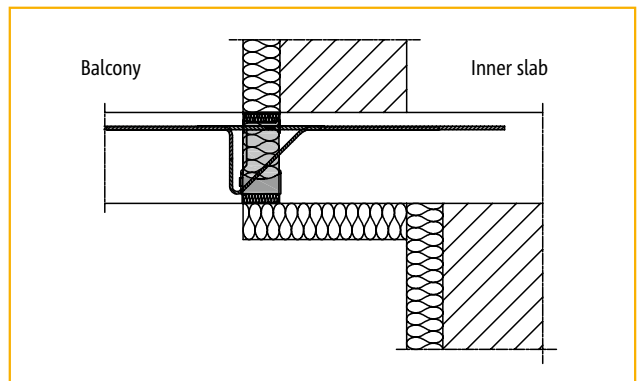
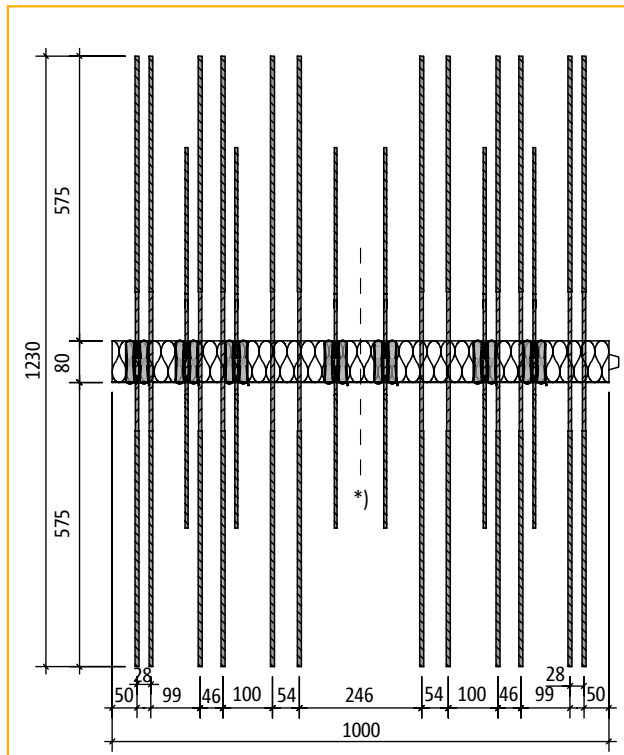

Figure 8: Balcony connection with an "indirect" support.

Schöck Isokorb® type K

Plan views



Plan view of Schöck Isokorb® type K30

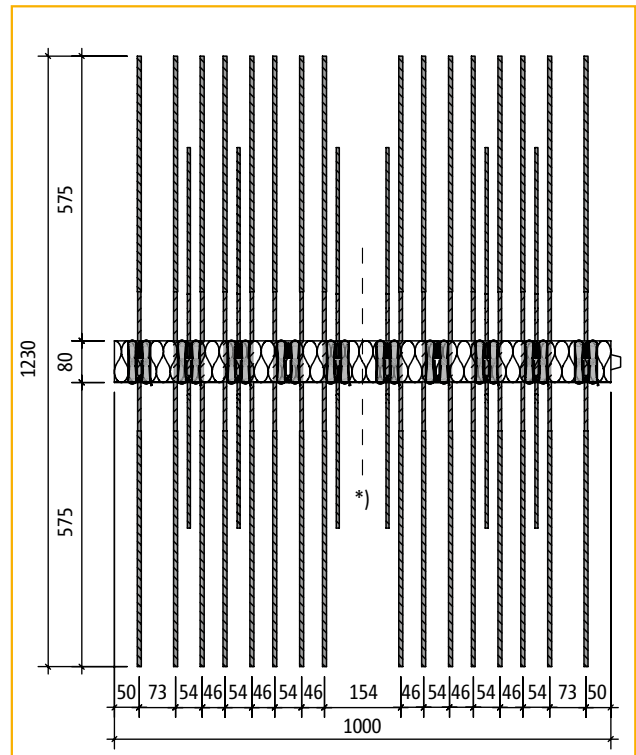

Plan view of Schöck Isokorb® type K50

*) On-site cutting possible at the shown position; this will result in a reduced load-bearing capacity.

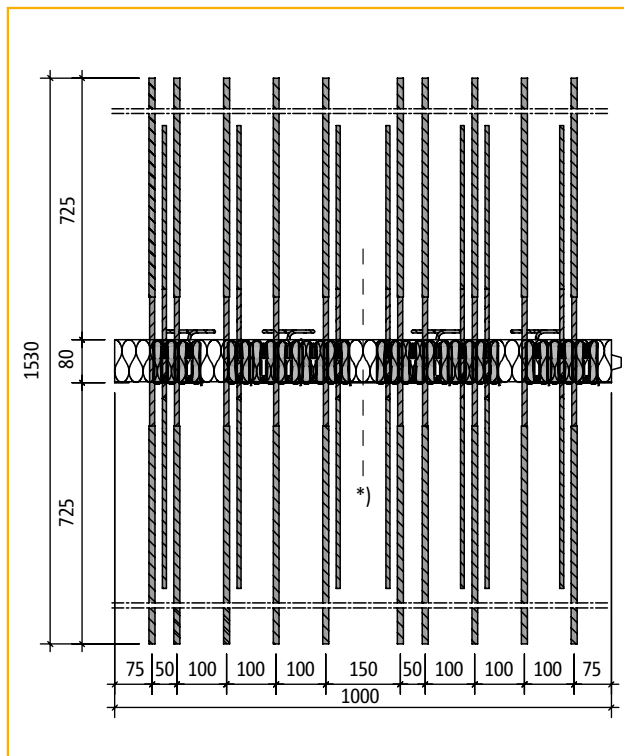

Plan view of Schöck Isokorb® type K60

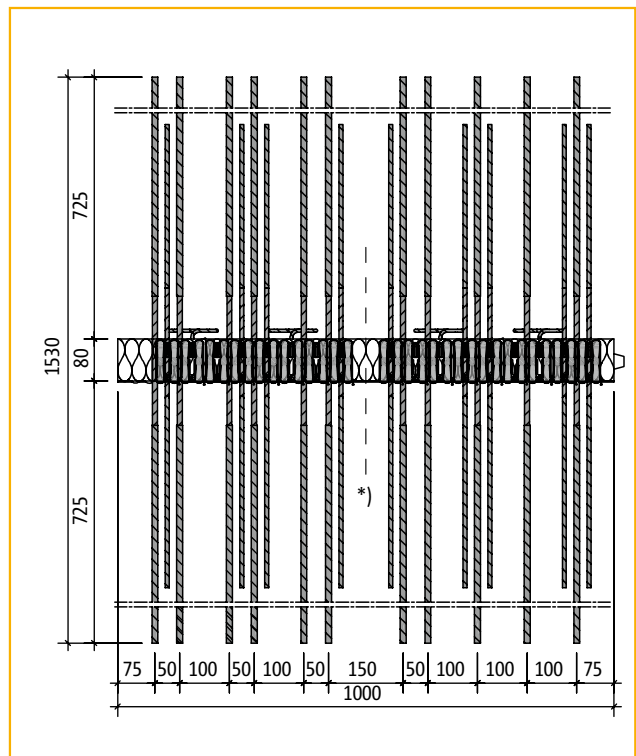

Plan view of Schöck Isokorb® type K80

Further plan views can be found at: www.schoeck.co.uk/en_gb/download/cad-drawings-3

ITE

K

Reinforced concrete-to-reinforced concrete

Schöck Isokorb® type K

Product variants/Designations

Product selection

Basic type

TE

K10 to K100 for transmission of bending moment and shear force

K

Shear force variant V6 = standard equipment, does not need to be listed in the type designation.

available from height 160 mm to 250 mm

Variants:

Shear force variant

e.g.: K50-CV35-V8... (= shear force bars 7 ϕ 8)
 K50-CV35-V10... (= shear force bars 9 ϕ 8)
 K50-CV35-VV... (= shear force bars 5 ϕ 8 positive + 4 ϕ 8 negative)

Concrete cover

e.g.: K50-CV30... (= installation dimensions for the tension bars CV = 30 mm)
 K50-CV35... (= installation dimensions for the tension bars CV = 35 mm)
 K50-CV50... (\cong 2nd layer) (= installation dimensions for the tension bars CV = 50 mm)

Fire protection

e.g.: K50-CV35-...-F90

Designations used in planning documents

(structural calculations, specification documents, implementation plans, orders), e.g.

K50-CV35-H180

Type+load range _____
 Concrete cover _____
 Height of Isokorb® _____

K50-CV35-V8-H180-F90

Type+load range _____
 Concrete cover _____
 Shear force variant _____
 Height of Isokorb® _____
 Fire protection class _____

Special designs – Bending reinforcing steels

Some connection layouts cannot be implemented with the standard product options shown in this document. In such cases, special designs can be requested from the Design Support Department (see p. 3 for contact details). This also applies for example to additional requirements for prefabricated constructions (restrictions due to manufacturing or transport constraints) which may be met using coupler bars.

Individual reinforcing steel bars are bent in the precast plant as required. The Schöck Isokorb components are then assembled. This ensures compliance with regulations of the technical approval.

If Isokorb reinforcing steel is later bent or bent and straightened again on site in contravention of this, then compliance and monitoring of the relevant conditions lies outside the responsibility of Schöck Bauteile GmbH, and the product warranty expires.

Schöck Isokorb® type K

Product description

Schöck Isokorb® type	K10	K20	K30	K40	K50
Isokorb® length [m]	1.00	1.00	1.00	1.00	1.00
Tension bars	4 \varnothing 8	8 \varnothing 8	12 \varnothing 8	13 \varnothing 8	16 \varnothing 8
Shear force bars V6	4 \varnothing 6	4 \varnothing 6	6 \varnothing 6	6 \varnothing 6	6 \varnothing 6
Shear force bars V8	5 \varnothing 8	5 \varnothing 8	7 \varnothing 8	7 \varnothing 8	7 \varnothing 8
Shear force bars V10	-	-	9 \varnothing 8	9 \varnothing 8	9 \varnothing 8
Shear force bars VV	-	-	-	5 \varnothing 8 + 4 \varnothing 8	5 \varnothing 8 + 4 \varnothing 8
Pressure bearings (qty)	4 (5 at V8)	5	7 (9 at V10)	8 (9/11 at V10/VV)	10 (14 at VV)

HTE

K

Schöck Isokorb® type	K60	K70	K80	K90	K100
Isokorb® length [m]	1,00	1.00	1.00	1.00	1.00
Tension bars	10 \varnothing 12	11 \varnothing 12	11 \varnothing 12	12 \varnothing 12	13 \varnothing 12
Shear force bars V6	7 \varnothing 8	8 \varnothing 8	-	-	-
Shear force bars V8	7 \varnothing 8	8 \varnothing 8	9 \varnothing 8	9 \varnothing 8	9 \varnothing 8
Shear force bars V10	9 \varnothing 8	9 \varnothing 8	9 \varnothing 8	9 \varnothing 8	10 \varnothing 8
Shear force bars VV	9 \varnothing 8 + 4 \varnothing 8	9 \varnothing 8 + 4 \varnothing 8	9 \varnothing 8 + 4 \varnothing 8	9 \varnothing 8 + 4 \varnothing 8	10 \varnothing 8 + 4 \varnothing 8
Pressure bearings (qty)	15 (17 at VV)	16(17 at VV)	17	18	18
Special hoops (qty)	4	4	4	4	4

Reinforced concrete-to-reinforced concrete

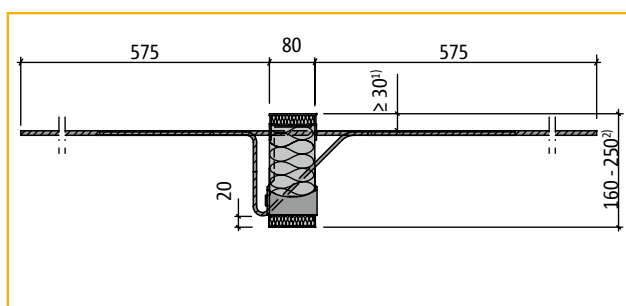

Schöck Isokorb® type K10 to K50

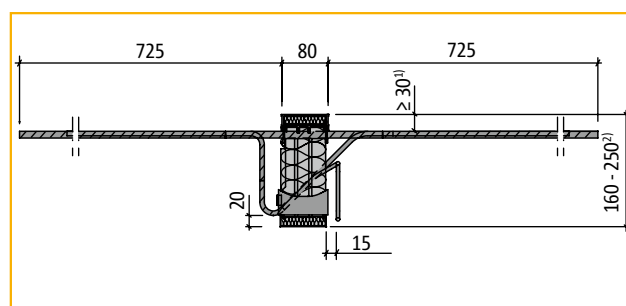

Schöck Isokorb® type K60 to K100

¹⁾ 35 mm for CV35, 50 mm for CV50

²⁾ 180 - 250 mm for CV50

Schöck Isokorb® type K

Capacity tables for C25/30

HITE

K

Reinforced concrete-to-reinforced concrete

Schöck Isokorb® type			K10	K20	K30	K40	K50	
Design values for	Concrete cover CV [mm]		Concrete grade ≥ C25/30					
	CV30	CV35	CV50 ¹⁾	Moment capacity m_{Rd} [kNm/m]				
Height of Isokorb® H [mm]		160		-7.3	-14.3	-20.0	-22.8	-28.6
	160		180	-7.7	-15.1	-21.2	-24.2	-30.3
		170		-8.1	-16.0	-22.4	-25.6	-32.0
	170		190	-8.6	-16.9	-23.6	-27.0	-33.7
		180		-9.0	-17.7	-24.8	-28.4	-35.4
	180		200	-9.4	-18.6	-26.0	-29.7	-37.2
		190		-9.9	-19.4	-27.2	-31.1	-38.9
	190		210	-10.3	-20.3	-28.4	-32.5	-40.6
		200		-10.8	-21.2	-29.6	-33.9	-42.3
	200		220	-11.2	-22.0	-30.8	-35.2	-44.0
		210		-11.6	-22.9	-32.0	-36.6	-45.8
	210		230	-12.1	-23.7	-33.2	-38.0	-47.5
		220		-12.5	-24.6	-34.4	-39.4	-49.2
	220		240	-12.9	-25.5	-35.6	-40.7	-50.9
		230		-13.4	-26.3	-36.8	-42.1	-52.6
	230		250	-13.8	-27.2	-38.1	-43.5	-54.4
		240		-14.3	-28.0	-39.3	-44.9	-56.1
240			-14.7	-28.9	-40.5	-46.2	-57.8	
	250		-15.1	-29.8	-41.7	-47.6	-59.5	
250			-15.6	-30.6	-42.9	-49.0	-61.2	
Shear force variant			Shear force capacity v_{Rd} [kN/m]					
	V6 (standard equipment) ²⁾		+28.0	+28.0	+42.0	+42.0	+42.0	
	V8		+62.2	+62.2	+87.1	+87.1	+87.1	
	V10		-	-	+112.0	+112.0	+112.0	
	VV		-	-	-	+62.2/-49.8	+62.2/-49.8	

Schöck Isokorb® type		K10	K20	K30	K40	K50
Product description	Isokorb® length [m]	1.00	1.00	1.00	1.00	1.00
	Tension bars	4 \emptyset 8	8 \emptyset 8	12 \emptyset 8	13 \emptyset 8	16 \emptyset 8
	Shear force variant V6 ²⁾	4 \emptyset 6	4 \emptyset 6	6 \emptyset 6	6 \emptyset 6	6 \emptyset 6
	Shear force variant V8	5 \emptyset 8	5 \emptyset 8	7 \emptyset 8	7 \emptyset 8	7 \emptyset 8
	Shear force variant V10	-	-	9 \emptyset 8	9 \emptyset 8	9 \emptyset 8
	Shear force variant VV	-	-	-	5 \emptyset 8 + 4 \emptyset 8	5 \emptyset 8 + 4 \emptyset 8
	Pressure bearings (qty)	4 (5 at V8)	5	7 (9 at V10)	8 (9/11 at V10/VV)	10 (14 at VV)
	Special hoops (qty)	-	-	-	-	-

Member forces to be taken 100 mm off the slab edge.

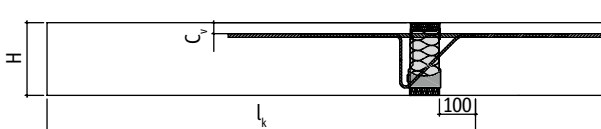

Schöck Isokorb® type **K50-CV35-V8-H180-F90**

Type + load range _____
 Concrete cover in mm _____
 Shear force variant _____
 Height of Isokorb® in mm _____
 Fire protection class _____

¹⁾ min. H = 180 mm for CV50

²⁾ Shear force variant V6 = standard variant up to K70

Schöck Isokorb® type K

Capacity tables for C25/30

Schöck Isokorb® type			K60	K70	K80	K90	K100	
Design values for	Concrete cover CV [mm]		Concrete grade \geq C25/30				\geq C30/37	
	CV30	CV35	CV50 ¹⁾	Moment capacity m_{Rd} [kNm/m]				
Height of Isokorb® H [mm]		160		-38.6	-41.2	-42.6	-46.4	-50.2
	160		180	-41.0	-43.8	-45.2	-49.2	-53.3
		170		-43.4	-46.3	-47.9	-52.1	-56.4
	170		190	-45.8	-48.8	-50.5	-55.0	-59.4
		180		-48.2	-51.4	-53.1	-57.8	-62.5
	180		200	-50.6	-53.9	-55.7	-60.7	-65.6
		190		-53.0	-56.5	-58.4	-63.5	-68.7
	190		210	-55.3	-59.0	-61.0	-66.4	-71.8
		200		-57.7	-61.6	-63.6	-69.3	-74.9
	200		220	-60.1	-64.1	-66.3	-72.1	-78.0
		210		-62.5	-66.7	-68.9	-75.0	-81.1
	210		230	-64.9	-69.2	-71.5	-77.9	-84.2
		220		-67.3	-71.7	-74.2	-80.7	-87.3
	220		240	-69.6	-74.3	-76.8	-83.6	-90.4
		230		-72.0	-76.8	-79.4	-86.4	-93.5
	230		250	-74.4	-79.4	-82.0	-89.3	-96.6
	240		-76.8	-81.9	-84.7	-92.2	-99.7	
240			-79.2	-84.5	-87.3	-95.0	-102.8	
	250		-81.6	-87.0	-89.9	-97.9	-105.9	
250			-84.0	-89.6	-92.6	-100.7	-109.0	
Shear force variant	Shear force capacity v_{Rd} [kN/m]							
	V6 (standard equipment) ²⁾			+42.0	+42.0	-	-	-
	V8			+87.1	+87.1	+87.1	+87.1	+87.1
	V10			+112.0	+112.0	+112.0	+112.0	+112.0
	VV			+112.0/-49.8	+112.0/-49.8	+112.0/-49.8	+112.0/-49.8	+112.0/-49.8
Schöck Isokorb® type			K60	K70	K80	K90	K100	
Product description	Isokorb® length [m]			1.00	1.00	1.00	1.00	1.00
	Tension bars			10 \emptyset 12	11 \emptyset 12	11 \emptyset 12	12 \emptyset 12	13 \emptyset 12
	Shear force variant V6 ²⁾			7 \emptyset 8	8 \emptyset 8	-	-	-
	Shear force variant V8			7 \emptyset 8	8 \emptyset 8	9 \emptyset 8	9 \emptyset 8	9 \emptyset 8
	Shear force variant V10			9 \emptyset 8	9 \emptyset 8	9 \emptyset 8	9 \emptyset 8	10 \emptyset 8
	Shear force variant VV			9 \emptyset 8 + 4 \emptyset 8	9 \emptyset 8 + 4 \emptyset 8	9 \emptyset 8 + 4 \emptyset 8	9 \emptyset 8 + 4 \emptyset 8	10 \emptyset 8 + 4 \emptyset 8
	Pressure bearings (qty)			15 (17 bei VV)	16 (17 bei VV)	17	18	18
Special hoops (qty)			4	4	4	4	4	

Notes:

- ▶ Concrete strength class for outside components at least C32/40 (see page 30).
- ▶ Concrete strength class C32/40 also required for inside slabs for use of K100.
- ▶ The verification of the shear force in slabs has to be provided by the structural designer according to EC2 clause 6.9..

¹⁾ min. H = 180 mm for CV50

²⁾ Shear force variant V6 = standard variant up to K70

Schöck Isokorb® type K

Installation in conjunction with precast planks

TE

K

Reinforced concrete-to-reinforced concrete

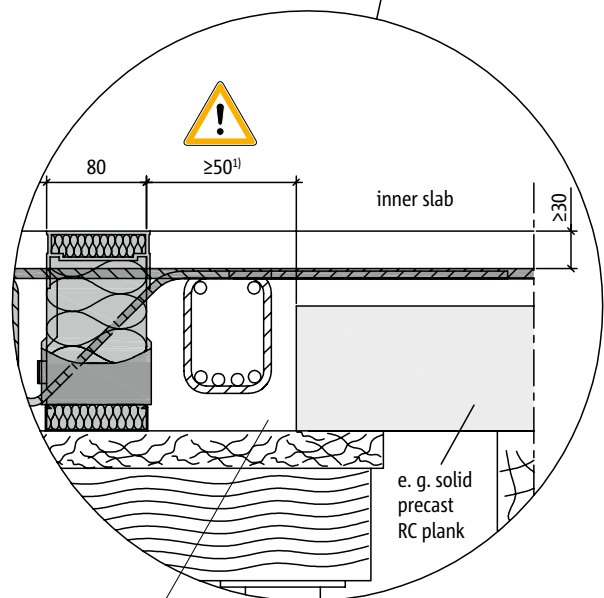
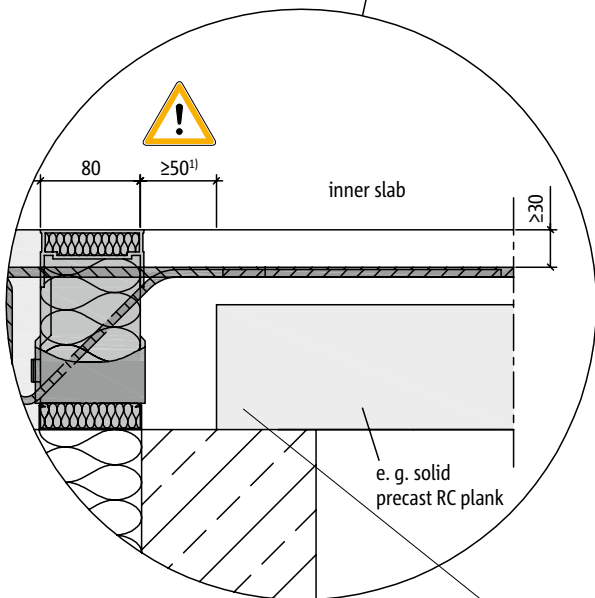
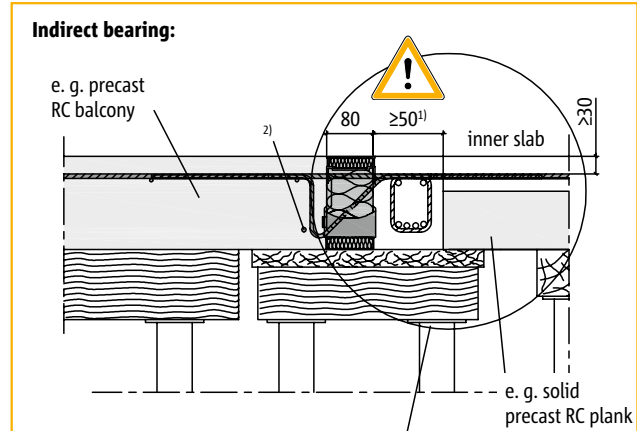
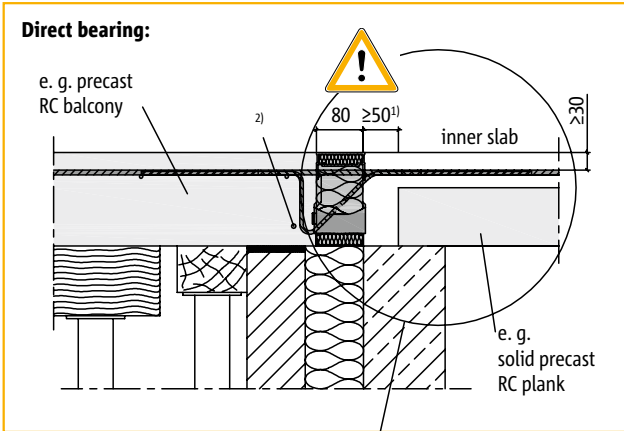

Structural design and reinforcement according to structural engineer

Notes

- ▶ A minimum cast-in-place strip of concrete between precast planks and Schöck Isokorb® is essential for structural reasons!
- ▶ Sufficient bond action between reinforced structural screed and precast planks has to be guaranteed!

¹⁾ A cast-in-place strip of concrete is essential for structural reasons.

²⁾ Steel bar T8 along the pressure bearings

Schöck Isokorb® type K

Expansion joint/Example showing joint detail

External balcony slabs are subject to changes in length as a result of temperature fluctuations. Due to the lengthening and shortening of the balcony slabs, the load-bearing elements which run through the thermal insulation may be shifted by up to several millimetres. To insure that the bars can survive many thousands of temperature changes, the edge bending stresses determined in tests must not be exceeded. The HTE module compensates for the movements by individually inclining each separate pressure element.

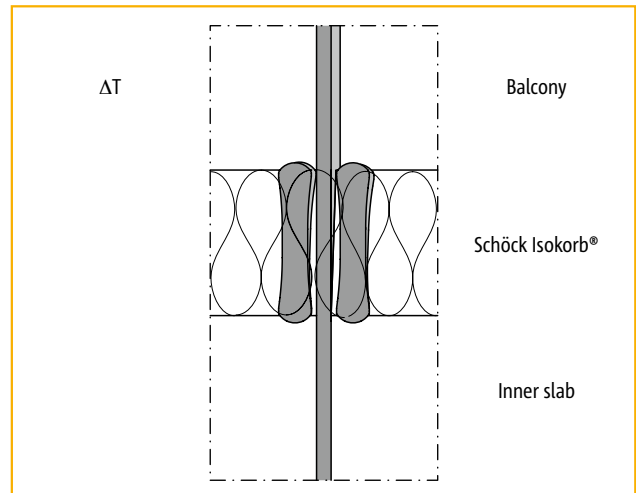

Deflection due to temperature difference

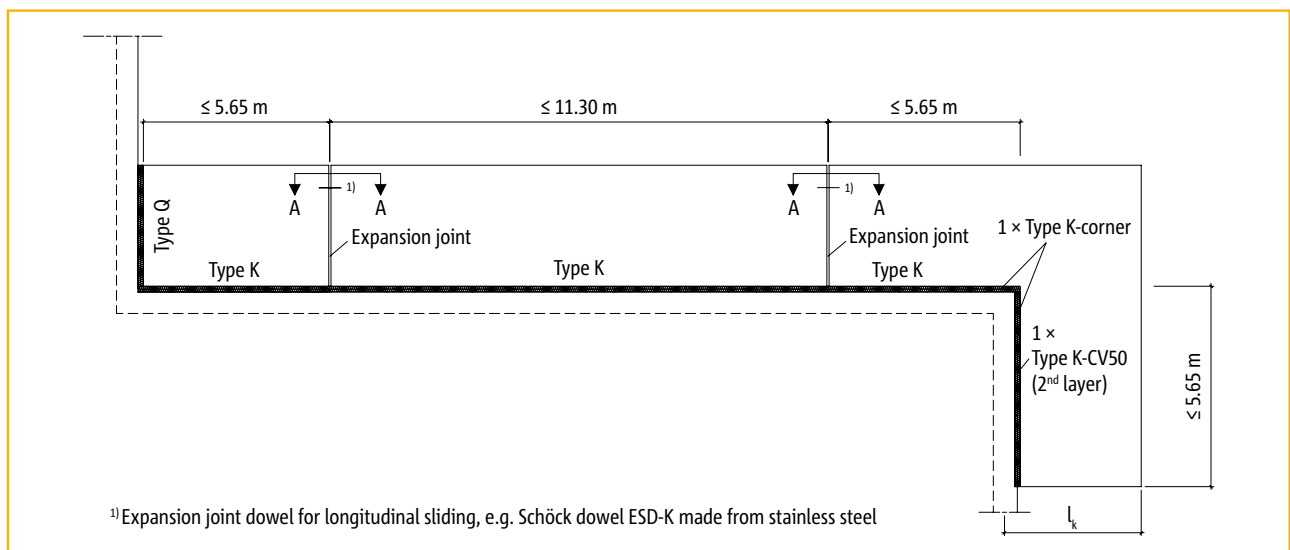

Expansion joint spacing

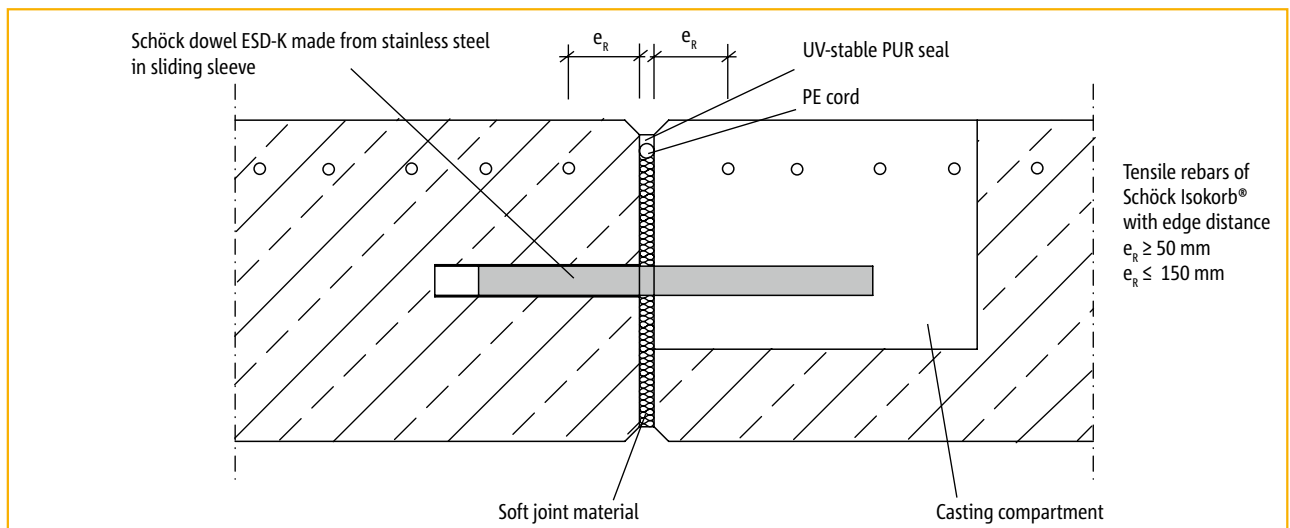

Example showing joint detail

HTE

K

Reinforced concrete-to-reinforced concrete

Schöck Isokorb® type K

Lap splice design

Direct mounting

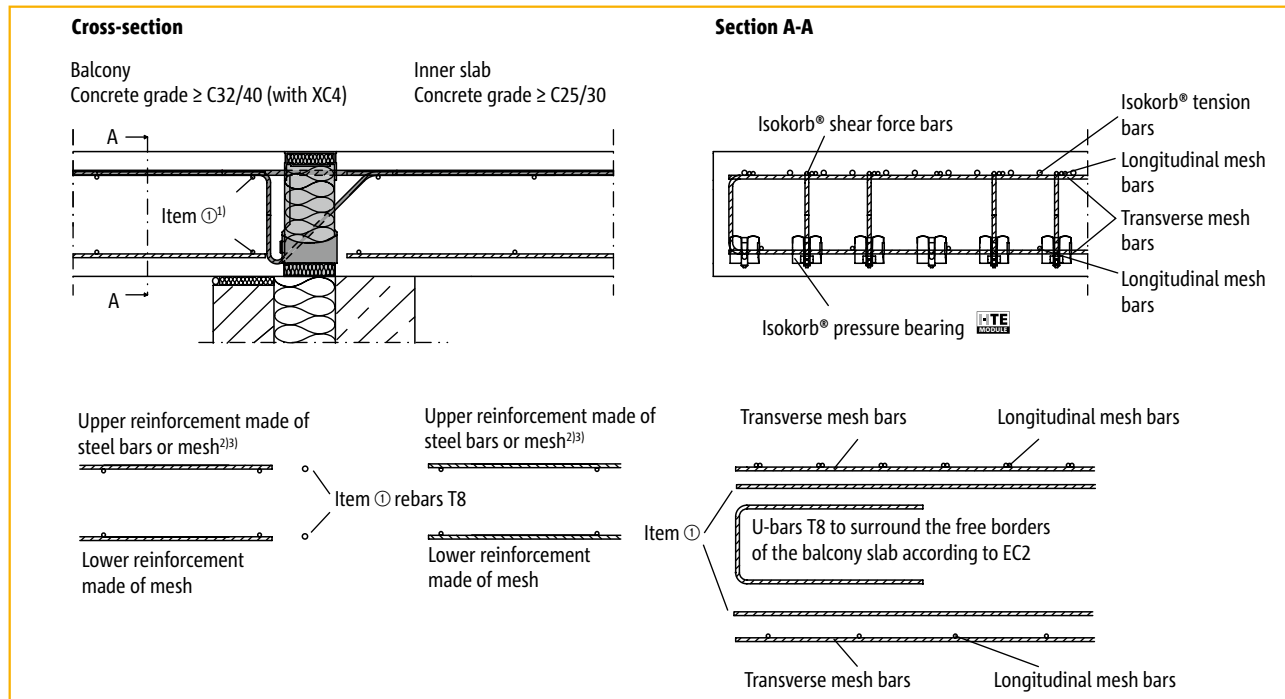

On-site additional reinforcement - direct mounting of inner slab border

Recommendations for lap splice design

- Option A: Connections with steel reinforcement mesh to BS 4483
- Option B: Connections with steel bars to BS 4449
- Option C: Combined reinforcement of connections with steel reinforcement mesh to BS 4483 and steel bars to BS 4449. The transverse reinforcement of the chosen steel reinforcement mesh covers 1/5 of the longitudinal reinforcement.

Recommendations for the reinforcement of connections with Schöck Isokorb® at a load of 100 % of the maximum rated moment with C25/30, CV = 35 mm or CV = 50 mm

Schöck Isokorb® type	Reinforcement options for design of tension laps ³⁾		
	Option A	Option B	Option C
K10	A193	T8@150 mm c/c	–
K20	B385	T10@150 mm c/c	A193 + T8@150 mm c/c
K30	B503	T10@125 mm c/c	A193 + T8@125 mm c/c
K40	B785	T10@100 mm c/c	A193 + T8@100 mm c/c
K50	B785	T10@90 mm c/c	A193 + T10@100 mm c/c
K60	–	T12@110 mm c/c	A252 + T10@90 mm c/c
K70	–	T12@100 mm c/c	A252 + T10@90 mm c/c
K80	–	T12@90 mm c/c	A252 + T12@100 mm c/c
K90	–	T12@80 mm c/c	A252 + T12@100 mm c/c
K100	–	T12@75 mm c/c	A385 + T12@100 mm c/c

¹⁾ The last transverse bar of the steel mesh must be positioned as closely as possible to the pressure bearing. Otherwise an T8 mm steel bar is required there.

²⁾ The calculations of the upper reinforcement layer are performed according to the standard calculation methods for reinforced steel construction.

³⁾ Alternative tension laps are also possible. The rules according to EC 2 apply to the determination of the lap length. It is permissible to reduce the required lap length with $A_{s,req}/A_{s,prov}$. For lapping (l) with the Schöck Isokorb®, a tension bar length of 530 mm can be used in the calculations for the types K10 to K50 and a tension bar length of 690 mm for the types K60 to K100.

Schöck Isokorb® type K

Lap splice design

Indirect mounting

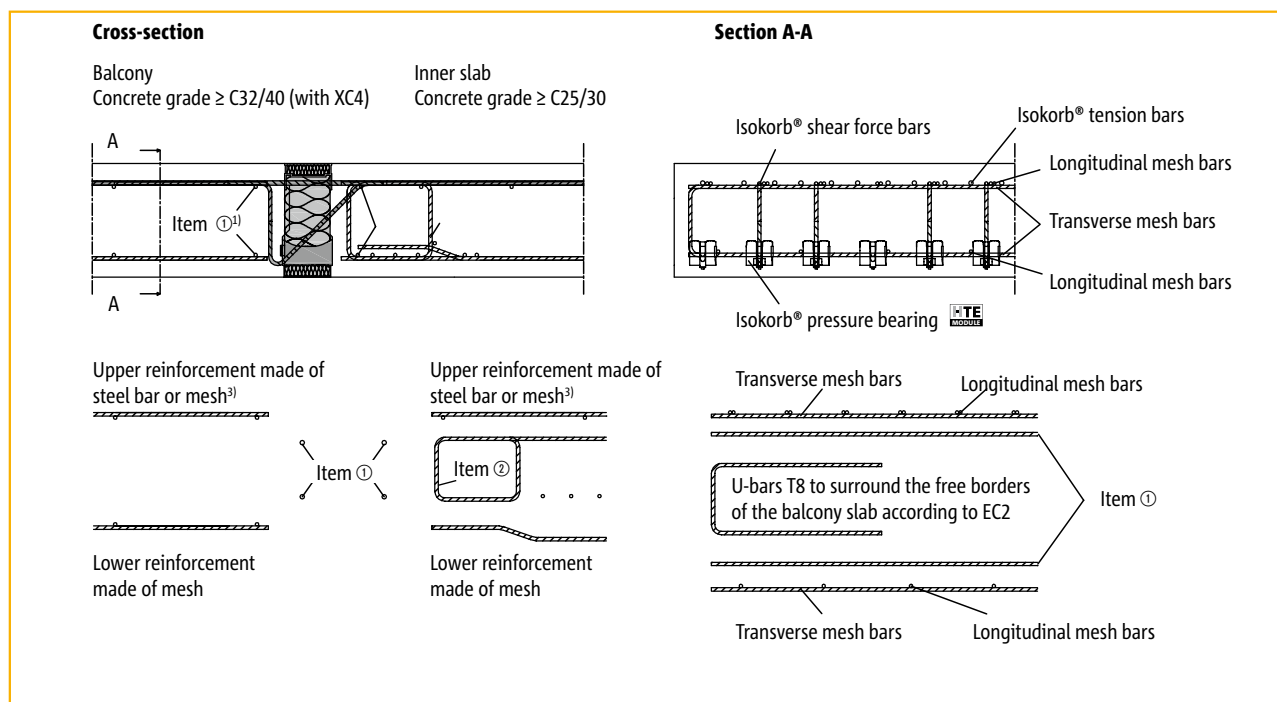

On-site additional reinforcement - indirect mounting of inner slab border

Recommendations for lap splice design

- Option A: Connections with steel reinforcement mesh to BS 4483
- Option B: Connections with steel bars to BS 4449
- Option C: Combined reinforcement of connections with steel reinforcement mesh to BS 4483 and steel bars to BS 4449. The transverse reinforcement of the chosen steel reinforcement mesh covers 1/5 of the longitudinal reinforcement.

Recommendations for the reinforcement of connections with Schöck Isokorb® at a load of 100 % of the maximum rated moment with C25/30, CV = 30 mm or CV = 35 mm

Schöck Isokorb® type	Required hanger-reinforcement (Item. ②) [mm²/m]									
	Height of Isokorb® H [mm]									
	160	170	180	190	200	210	220	230	240	250
K10	113									
K20	113									
K30	113									
K40	115									
K50	143									
K60	251	266	278	290	300	309	317	325	332	338
K70	279	295	309	322	333	343	353	361	369	376
K80	307	325	340	354	366	377	388	397	406	413
K90	325	344	360	375	388	400	410	420	429	438
K100	352	372	389	405	419	432	444	455	464	474

¹⁾ The last transverse bar of the steel mesh must be positioned as closely as possible to the pressure bearing. Otherwise an T8 mm steel bar is required there.

²⁾ The calculations of the upper reinforcement layer are performed according to the standard calculation methods for reinforced steel construction.

³⁾ Alternative tension laps are also possible. The rules according to EC 2 apply to the determination of the lap length. It is permissible to reduce the required lap length with $A_{s,req}/A_{s/prov}$. For lapping (l_s) with the Schöck Isokorb®, a tension bar length of 530 mm can be used in the calculations for the types K10 to K50 and a tension bar length of 690 mm for the types K60 to K100.

Schöck Isokorb® type K

Example calculation/Notes

Example calculation

preset: Cantilever balcony

TE

K

Member forces to be taken 100 mm off the slab edge.

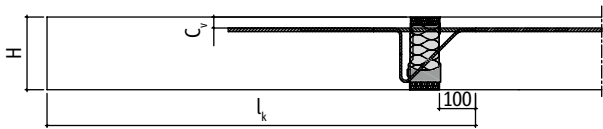

Geometry: Length of projection $l_k = 1.90$ m
Balcony slab thickness $H = 180$ mm

Load assumptions: Balcony slab and coating $g = 5.7$ kN/m²
Live load $q = 4.0$ kN/m²
Edge load (balustrade) $g_R = 1.5$ kN/m

Exposure grade: outside XC 4
inside XC 1

Choice: Concrete grade C25/30 for balcony, C32/40 for inner slab
Concrete cover CV = 35 mm for Isokorb®-tensile bars¹⁾

Member forces: $m_{Ed} = -[(\gamma_G \times g + \gamma_q \times q) \times l_k^2 / 2 + \gamma_G \times g_R \times l_k]$
 $m_{Ed} = -[(1.35 \times 5.7 + 1.5 \times 4.0) \times 1.9^2 / 2 + 1.35 \times 1.5 \times 1.9] = -28.6$ kNm/m
 $v_{Ed} = +(\gamma_G \times g + \gamma_q \times q) \times l_k + \gamma_G \times g_R$
 $v_{Ed} = +(1.35 \times 5.7 + 1.5 \times 4.0) \times 1.9 + 1.35 \times 1.5 = +28.1$ kN/m

Choice: **Schöck Isokorb® type K50-CV35-H180**

$m_{Rd} = -35.4$ kNm/m (see page 34) $> m_{Ed}$
 $v_{Rd} = +42.0$ kN/m (see page 34) $> v_{Ed}$
 $\tan \alpha = 0.8$ (see page 41)

Notes

- ▶ In the case of a combination of different concrete grades (e.g. balcony C32/40, inner slab C25/30), the weaker concrete is critical in terms of the Isokorb® calculations.
- ▶ The verification of the shear force in slabs has to be provided by the structural designer according to EC2 clause 6.9.
- ▶ Concrete grade for outside components at least C32/40 (see page 28).

Schöck Isokorb® type K

Deflection/Flexural slenderness

Deflection

The deflection factors shown in the table below result solely from the deformation of the Schöck Isokorb® element under 100 % exploitation of the steel stress of $f_{yd} = 609 \text{ N/mm}^2$. The final precamber of the balcony slab formwork results from the calculation according to BS 8500, or according to EC 2, plus the precamber due to the Schöck Isokorb®.

The precamber of the balcony formwork to be specified by the engineer in charge. Note that deflection calculations, or precamber design respectively, should be taken into account while designing the drainage of the balcony.

HTE

K

Deflection (p) due to Schöck Isokorb®

$$p = [\text{table value} \times l_k \times (m_{pd}/m_{Rd})] \times 10 \text{ [mm]}$$

- l_k Length of projection [m]
- m_{pd} Appropriate bending moment for calculation of the deflection p due to Schöck Isokorb®. The load combination to be applied here can be determined by the structural analysis engineer.
- m_{Rd} Maximum rated moment of the Schöck Isokorb® type K (see pages 34 - 35).

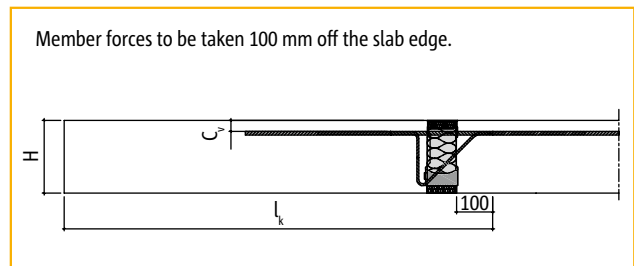

Schöck Isokorb® type		Deflection factor $\tan \alpha$ [%] at height of Isokorb® H [mm]									
		160	170	180	190	200	210	220	230	240	250
K10 - K50	CV30/CV35	0,9	0,8	0,8	0,7	0,6	0,6	0,6	0,5	0,5	0,5
	CV50	-	-	0,9	0,8	0,8	0,7	0,6	0,6	0,6	0,5
K60 - K100	CV30/CV35	1,1	1,0	0,9	0,8	0,7	0,7	0,6	0,6	0,6	0,5
	CV50	-	-	1,1	1,0	0,9	0,8	0,7	0,7	0,6	0,6

Example calculation

Choice: Concrete grade C32/40 for balcony
Concrete grade C25/30 for inner slab
Concrete cover CV = 35 mm

Choice: Schöck Isokorb® type K50-CV35-H180
 $m_{Rd} = -35.4 \text{ kNm/m}$ (see page 34) $> m_{Ed}$
 $v_{Rd} = +42.0 \text{ kN/m}$ (see page 34) $> v_{Ed}$
 $\tan \alpha = 0.8$ (see table above)

Geometry: Length of projection $l_k = 1.90 \text{ m}$
Concrete slab thickness $h = 180 \text{ mm}$

Chosen load combination for deflection due to Schöck Isokorb®: $g + q/2$

Load assumptions: Balcony slab and finish $g = 5.7 \text{ kN/m}^2$
Live load $q = 4.0 \text{ kN/m}^2$
Edge load (balustrade) $g_R = 1.5 \text{ kN/m}$

$$m_{pd} = -[(\gamma_G \times g + \gamma_Q \times q/2) \times l_k^2/2 + \gamma_G \times g_R \times l_k]$$

$$m_{pd} = -[(1.35 \times 5.7 + 1.5 \times 4/2) \times 1.9^2/2 + 1.35 \times 1.5 \times 1.9]$$

$$= -23.2 \text{ kNm/m}$$

Member forces: Bending moment $m_{Ed} = -28.6 \text{ kNm/m}$
Shear force $v_{Ed} = +28.1 \text{ kN/m}$

$$p = [\tan \alpha \times l_k \times (m_{pd}/m_{Rd})] \times 10$$

$$p = [0.8 \times 1.9 \times (23.2/35.4)] \times 10 = 10 \text{ mm}$$

For the limitation of flexible slenderness, we advise the following maximum cantilevered lengths $\max l_k$ [m]:

Concrete cover	Height of Schöck Isokorb® H [mm]									
	160	170	180	190	200	210	220	230	240	250
CV = 30 mm	1.81	1.95	2.10	2.25	2.39	2.54	2.68	2.83	2.98	3.12
CV = 35 mm	1.74	1.88	2.03	2.17	2.32	2.46	2.61	2.76	2.90	3.05
CV = 50 mm	1.52	1.66	1.81	1.95	2.10	2.25	2.39	2.54	2.68	2.83

Reinforced concrete-to-reinforced concrete

Schöck Isokorb® type K

Method statement

TE

K

Reinforced concrete-to-reinforced concrete

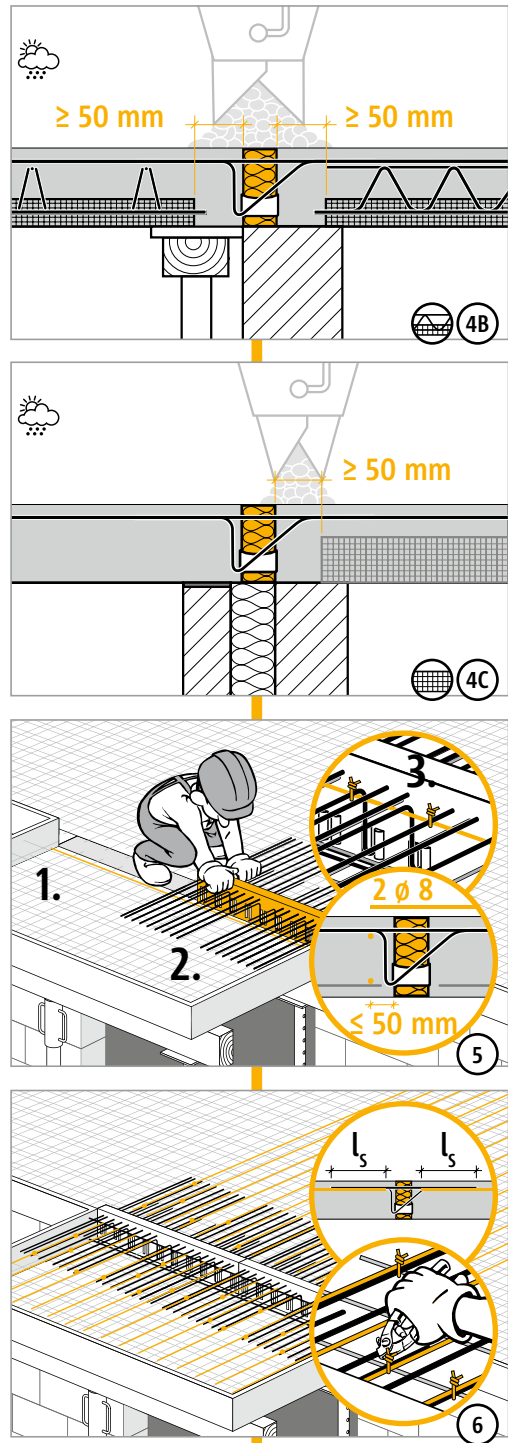
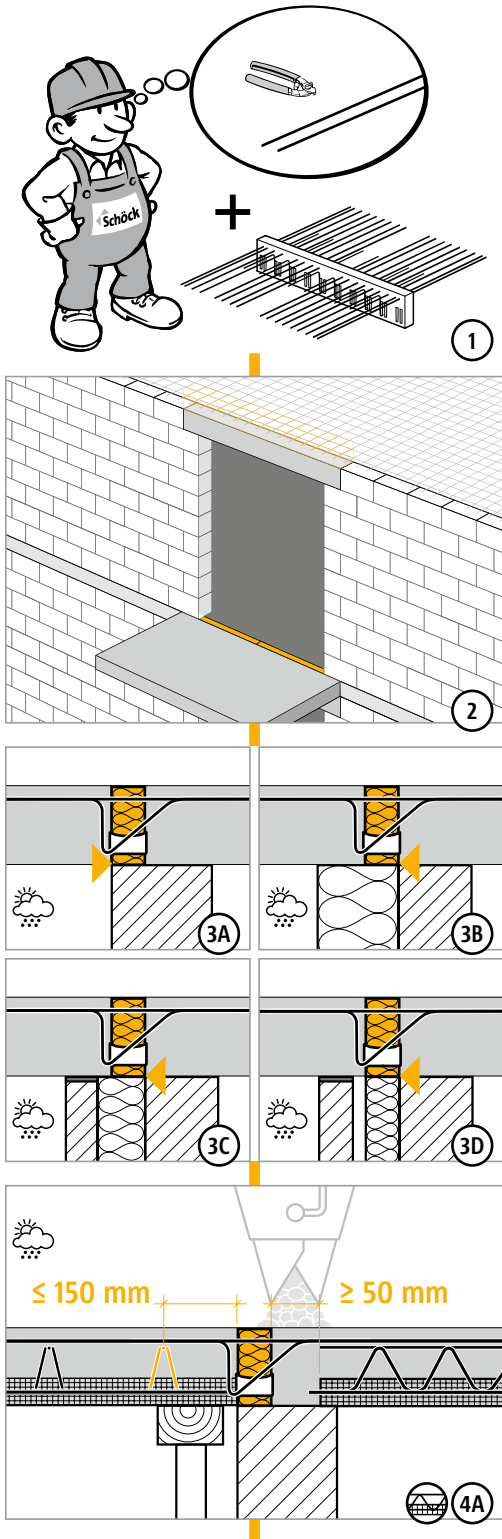

Schöck Isokorb®

Check list



- Have the member forces on the Isokorb® connection been determined at the design level?
- Was the cantilevered system length used in the process (Member forces to be taken 100 mm off the slab edge.)?
- Have the concrete cover and the appropriate concrete grade been taken into consideration according to the building regulations (see page 23)
- In case of precast planks will be used, is sufficient bond action between structural screed and precast planks guaranteed?
- Have the maximum permitted distances between expansion joints (= expansion joint spacing) been taken into account?
- Has the required lap splice reinforcement been designed for balcony side and for inner slab side?
- Do the calculations of the deformation of the overall structure take into account the additional deformation due to the Schöck Isokorb®?
- Has the drainage direction been taken into account in the resulting precamber specification for the balcony formwork?
- Has the relevant bearing limit of the slab been checked for Shear forces according to EC2 clause 6.9.?
- In case of a corner balcony, have the minimum slab thickness (≥ 180 mm) and the required 2nd layer (CV50) been taken into account?
- Have the fire safety requirements been clarified, and are they reflected in the chosen type designation (e.g. -F90)?
- In the case of F90 elements, has the increased minimum slab thickness been taken into account (type Q, type V)?

TE

K

Reinforced concrete-to-reinforced concrete

Schöck Isokorb® type K-corner

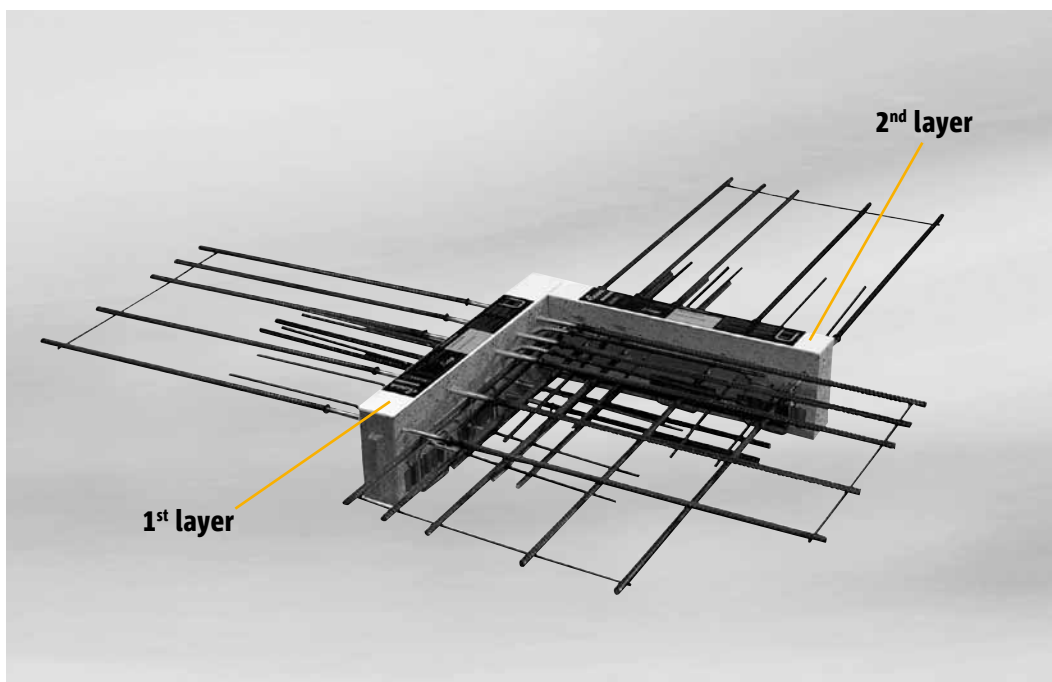

Schöck Isokorb® type K-corner (consists of two partial units, 1st layer and 2nd layer)

Contents	Page
Arrangement of elements/Note	46
Capacity table/Notes	47
Reinforcement layout Schöck Isokorb® type K20-corner-CV35/Lap splice design	48
Reinforcement layout Schöck Isokorb® type K30-corner-CV35/Lap splice design	49
Reinforcement layout Schöck Isokorb® type K50-corner-CV35/Lap splice design	50
Method statement/Notes	51 - 52
Check list	53
Fire resistance	16 - 17

Schöck Isokorb® type K-corner

Arrangement of elements/Note

As an addition to the Schöck Isokorb® type K, for balconies with outside corners the corresponding Schöck Isokorb® type K-corner is used:

TE

Type K20-CV35 → Type K20-corner-CV35
 Type K30-CV35 → Type K30-corner-CV35
 Type K50-CV35 → Type K50-corner-CV35

Each corner element comprises 2 parts:
 The partial unit for the 1st layer and the partial unit for the 2nd layer.

Next to the partial units for the 2nd layer, a Schöck Isokorb® type K-CV50 (2nd layer) unit is always required.

Refer to page 37 for details of the expansion joint spacing.

The mounting reinforcement and edge border on the balcony side are integrated at the factory. Calculations are performed following F. Leonhardt, "Vorlesungen über Massivbau" (Lectures on solid construction), part 3, paragraph 8.3.4.

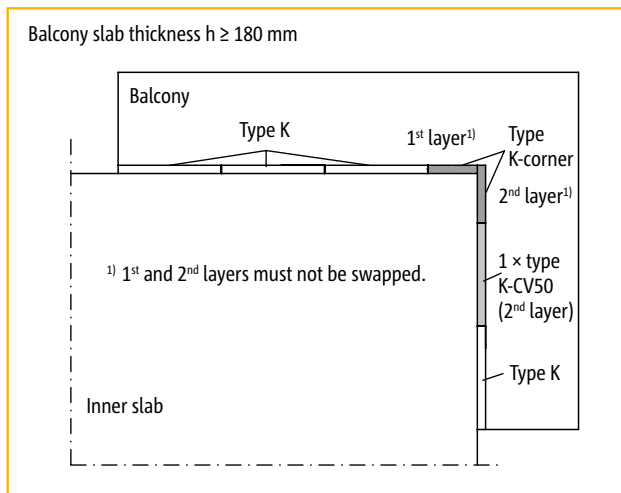

Isokorb® arrangement e. g. with precast lattice girder floor slabs

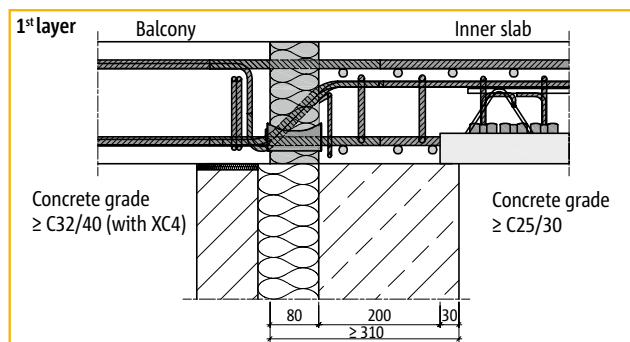

Section through partial unit, 1st layer with cavity wall

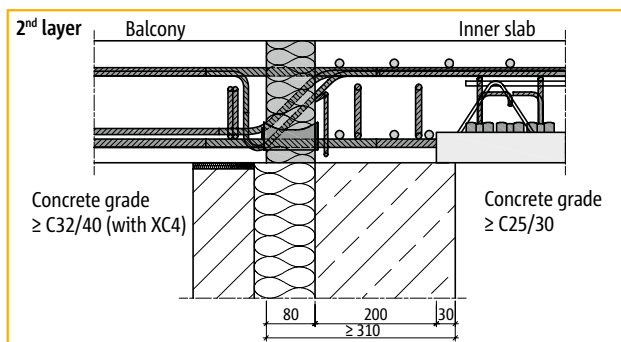

Section through partial unit, 2nd layer with cavity wall

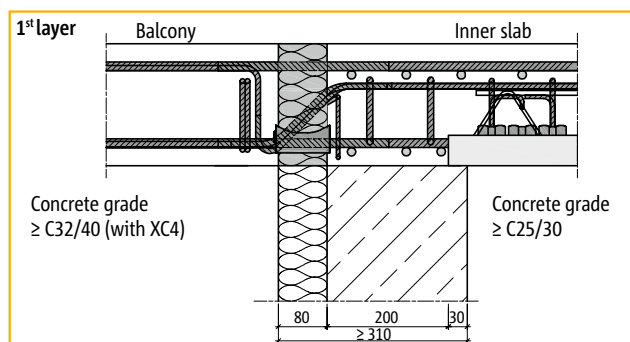

Section through partial unit, 1st layer, brickwork with external insulation

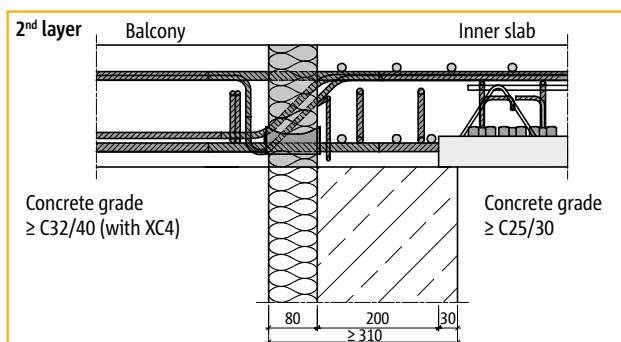

Section through partial unit, 2nd layer, brickwork with external insulation

Note

- ▶ When installing Schöck Isokorb® type K30-corner and type K50-corner units, a clear gap of at least 200 mm is required between the insulating body and the precast plank on the inner slab side for anchoring of the compression bars \varnothing 14 mm which are located at the bottom. This is not required for the Schöck Isokorb® type K20-corner; instead of that a cast-in-place strip of concrete \geq 50 mm between precast planks and Schöck Isokorb® is essential!

Schöck Isokorb® type K-corner

Capacity table/Notes

Schöck Isokorb® type		K20-corner	K30-corner	K50-corner
Design values for	Concrete cover ¹⁾ CV [mm]	Concrete grade ≥ C25/30		
	CV30 CV35	Moment capacity M_{Rd} [kNm] per partial unit (1st layer + 2nd layer)		
Height of Isokorb® H [mm]	180	-14.3	-31.8	-36.9
	180	-15.1	-33.4	-38.9
	190	-16.0	-35.3	-41.0
	190	-16.9	-36.9	-42.9
	200	-17.7	-38.8	-45.0
	200	-18.6	-40.5	-47.0
	210	-19.4	-42.3	-49.1
	210	-20.3	-44.0	-51.0
	220	-21.2	-45.8	-53.1
	220	-22.0	-47.5	-55.1
	230	-22.9	-49.3	-57.2
	230	-23.7	-51.0	-59.1
	240	-24.6	-52.8	-61.2
	240	-25.5	-54.5	-63.2
250	-26.3	-56.4	-65.3	
250	-27.2	-58.1	-67.3	
Shear force variants	Shear force capacity V_{Rd} [kN] per partial unit (1st layer + 2nd layer)			
	H = 180 - 190 mm	+37.3	+78.6	+91.1
	H ≥ 200 mm	+37.3	+106.7	+119.2

HTE

K-corner

Reinforced concrete-to-reinforced concrete

Schöck Isokorb® type		K20-corner		K30-corner		K50-corner	
		1 st layer	2 nd layer	1 st layer	2 nd layer	1 st layer	2 nd layer
Product description	Isokorb® length [m]	500	500	620	620	620	620
	Tension bars	8 ∅ 8	8 ∅ 8	5 ∅ 14	5 ∅ 14	6 ∅ 14	6 ∅ 14
	Compression bars	–	–	3 ∅ 14	3 ∅ 14	4 ∅ 14	4 ∅ 14
	Pressure bearings	5	5	6	6	6	6
	Shear force bars at						
	H = 180 - 190 mm	3 ∅ 8	3 ∅ 8	3 ∅ 8 + 2 ∅ 10	3 ∅ 8 + 2 ∅ 10	4 ∅ 8 + 2 ∅ 10	4 ∅ 8 + 2 ∅ 10
	H ≥ 200 mm	3 ∅ 8	3 ∅ 8	3 ∅ 8 + 2 ∅ 12	3 ∅ 8 + 2 ∅ 12	4 ∅ 8 + 2 ∅ 12	4 ∅ 8 + 2 ∅ 12

Designations used in planning documents

(structural calculations, specification documents, implementation plans, orders), e.g.

Schöck Isokorb® type **K50-corner-CV35-H180-F90** (consists of two partial units, 1st layer and 2nd layer)

Type + load range

Concrete cover in mm

Height of Isokorb® in mm

Fire protection class

Notes

- ▶ Concrete grade for outside components at least C32/40 (see page 28).
- ▶ The verification of the shear force in slabs has to be provided by the structural designer according to EC2 clause 6.9..

¹⁾ Concrete cover CV in respect of tension bars in 1st layer element

Schöck Isokorb® type K30-corner-CV35

Reinforcement layout/Lap splice design

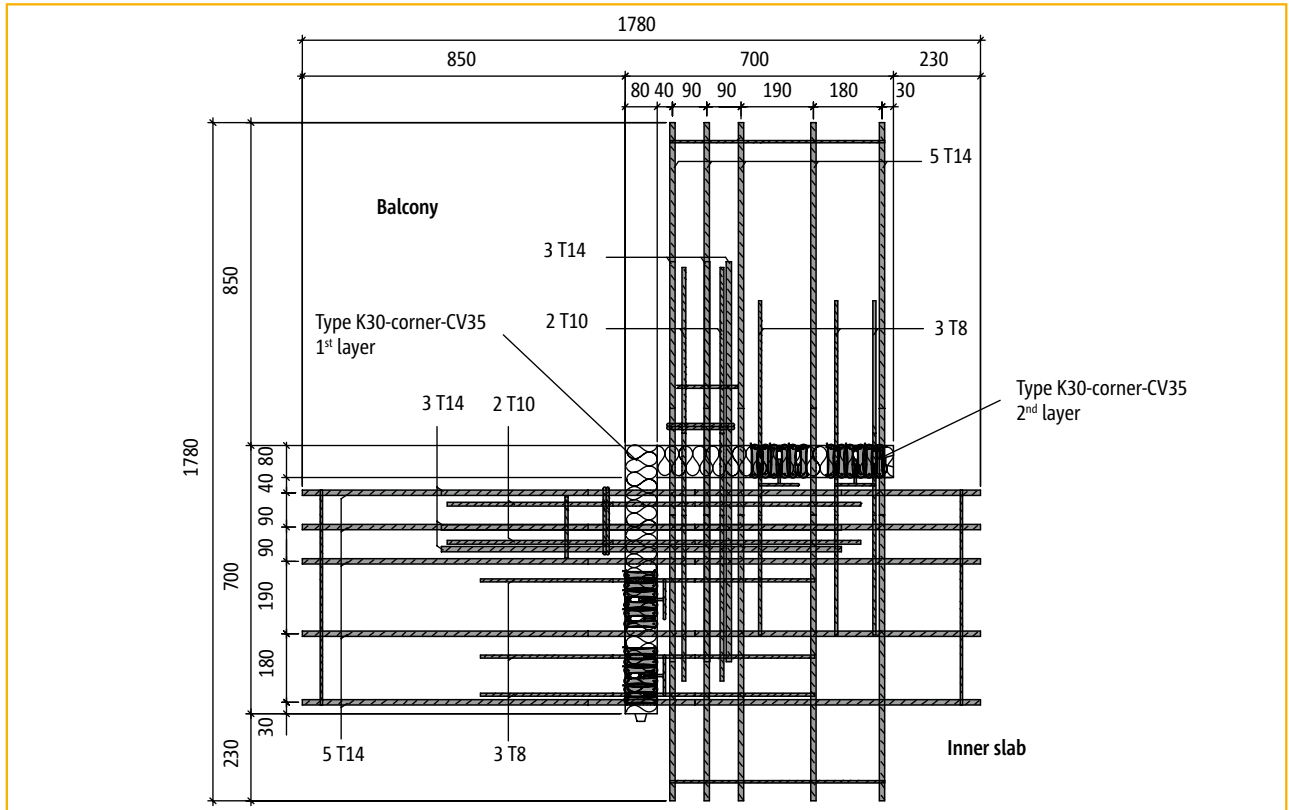

Plan view: Schöck Isokorb® type K30-corner-CV35

HTE

K-corner

Reinforced concrete-to-reinforced concrete

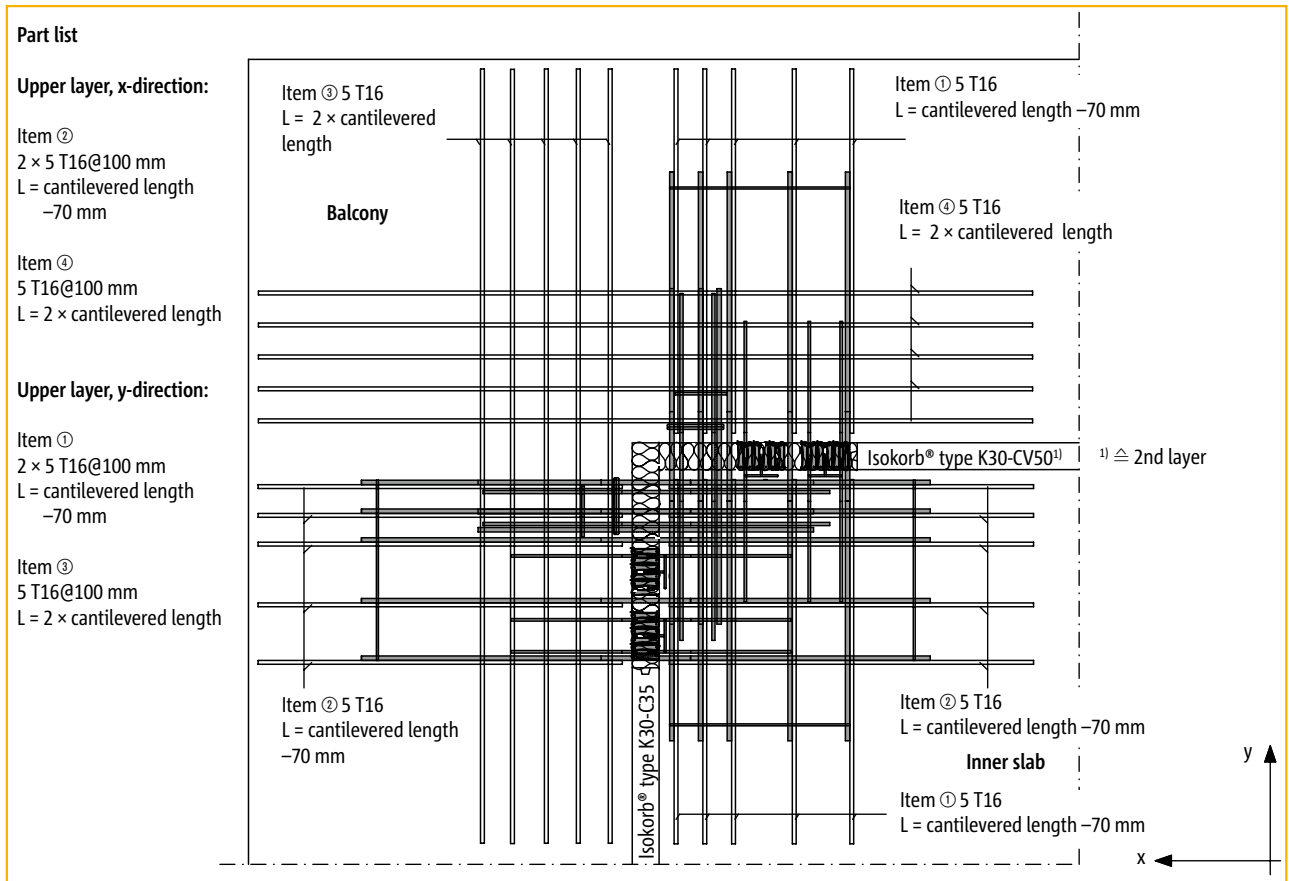

Lap splice design for on-site reinforcement (upper layer in the area of the Schöck Isokorb® type K30-corner-CV35)

Schöck Isokorb® type K-corner

Method statement

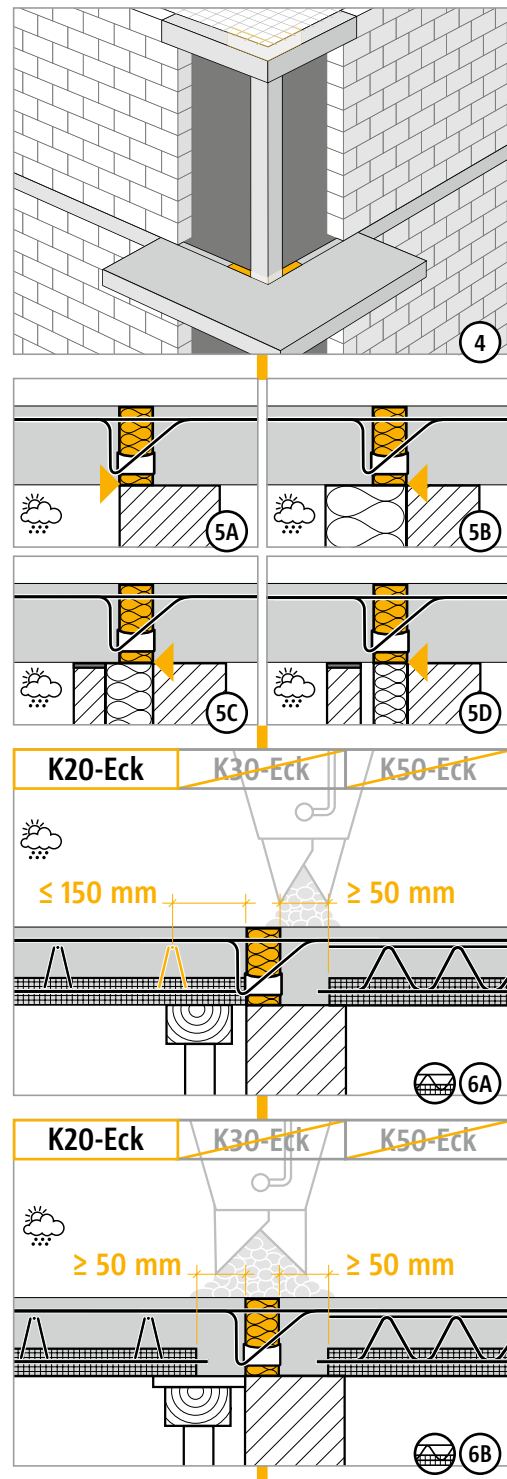
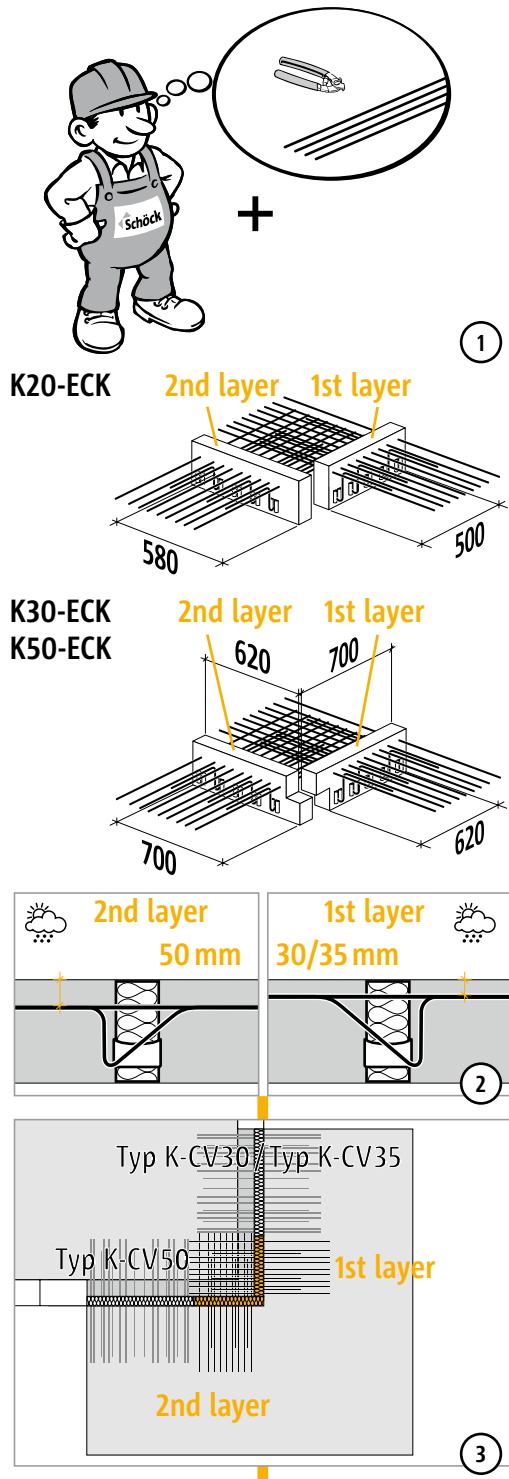

HTE

K-corner

Reinforced concrete-to-reinforced concrete

Schöck Isokorb® type K-corner

Method statement/Notes

TE

K-corner

Reinforced concrete-to-reinforced concrete

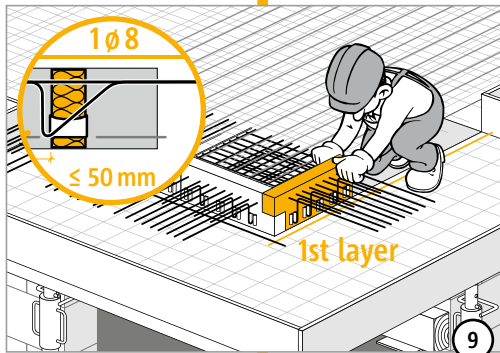
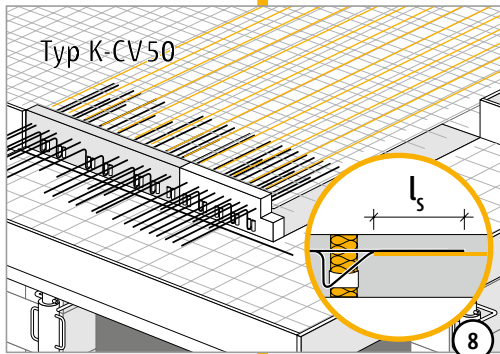
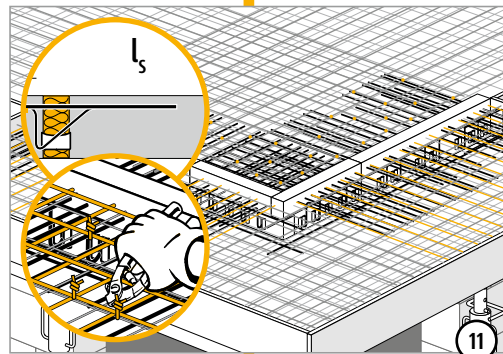
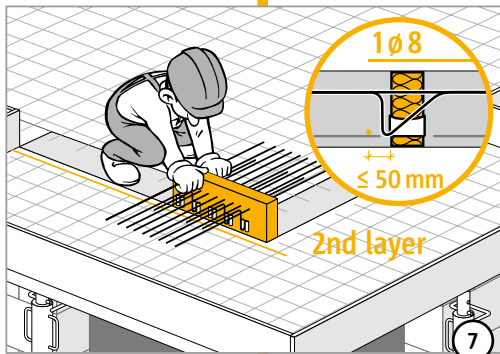
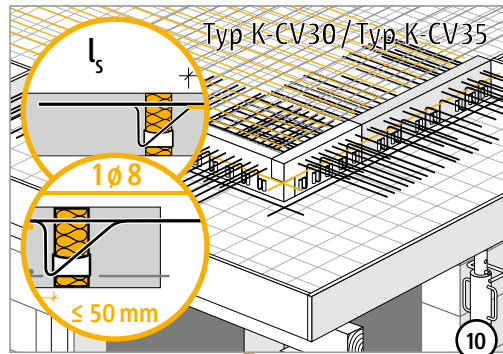
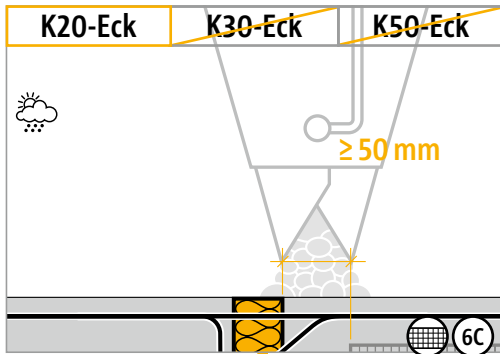

Notes

- ▶ Concrete grade for outside components at least C32/40 (see page 28).
- ▶ Reinforcement joints according to the information provided by the structural design engineer.
- ▶ In order to secure the position of the Schöck Isokorb® during concreting, it is important that both sides are evenly filled and compacted.
- ▶ Precamber of the balcony slab and concrete cover in accordance with the information provided by the structural design engineer or the construction management.
- ▶ Refer to page 37 for details of the maximum expansion joint spacing.
- ▶ The verification of the shear force in slabs has to be provided by the structural designer according to EC2 clause 6.9..

Schöck Isokorb® type K-corner

Check list



- Have the member forces on the Isokorb® connection been determined at the design level?
- Was the cantilevered system length used in the process (Member forces to be taken 100 mm off the slab edge.)?
- Have the concrete cover and the appropriate concrete grade been taken into consideration according to the building regulations (see page 23)
- In case of precast planks will be used, is sufficient bond action between reinforced structural screed and precast planks guaranteed?
- Have the maximum permitted distances between expansion joints (= expansion joint spacing) been taken into account?
- Has the required lap splice reinforcement been designed?
- Do the calculations of the deformation of the overall structure take into account the additional deflection due to the Schöck Isokorb®?
- Has the drainage direction been taken into account in the resulting precamber specification of the balcony framework?
- Has the relevant bearing limit of the slab been checked for Shear forces according to EC2 clause 6.9.?
- In case of corner a balcony, have the minimum slab thickness (≥ 180 mm) and the required 2nd layer (CV50) been taken into account?
- Have the fire safety requirements been clarified, and are they reflected in the chosen type designation (-F90)?
- In the case of F90 elements, has the increased minimum slab thickness been taken into account (type Q, type V)?

HTE

K-corner

Reinforced concrete-to-reinforced concrete

Schöck Isokorb® type K-HV, K-BH, K-WO, K-WU

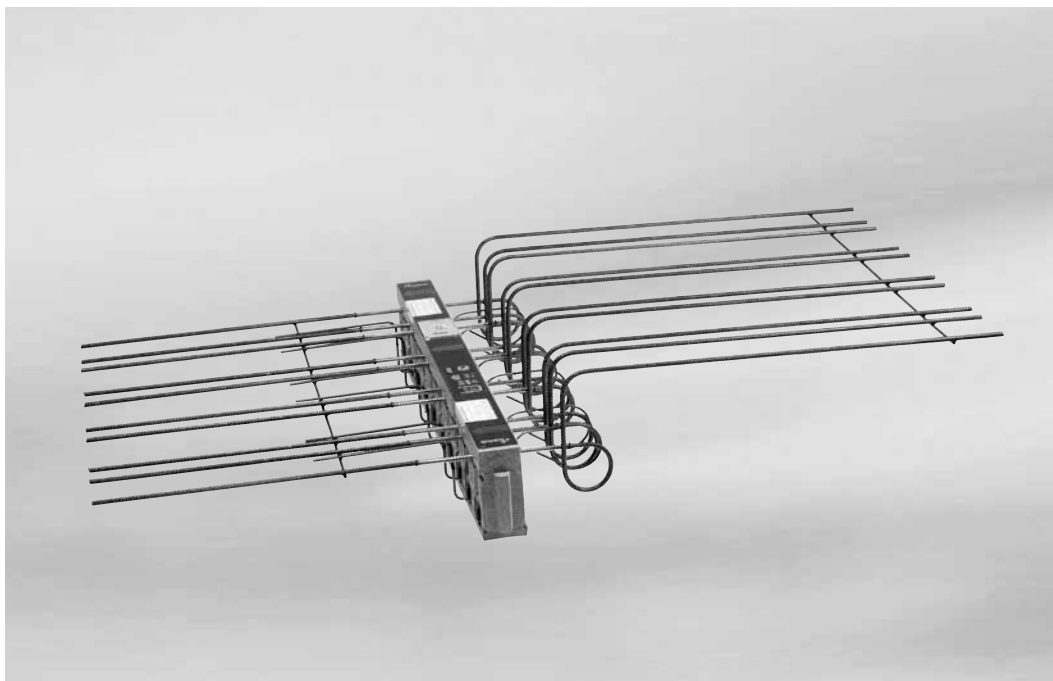

Schöck Isokorb® type K-HV

HTE

K-HV
K-BH
K-WO
K-WU

Reinforced concrete-to-reinforced concrete

Contents	Page
Schöck Isokorb® type K-HV-CV35 - connection to a step down balcony	56
Schöck Isokorb® type K-BH-CV35 - connection to a step up balcony	57
Schöck Isokorb® type K-WO-CV35 and type K-WU-CV35 – connection to reinforced concrete walls	58
Product description/Capacity tables/Notes	59
Deflection/Example calculation/Notes	60
Lap splice design	61 - 63
Method statement	64 - 65
Check list	66
Fire resistance	16 - 17

Schöck Isokorb® type K-HV

Connection to a step down balcony

Standard element Schöck Isokorb® type K-CV35

Condition: $HV \leq h_d - CV - d_s - c_i$

TE

With: HV = downstand
 h_d = inner slab thickness
 CV = external concrete cover
 d_s = diameter of the Isokorb® tension bar
 c_i = internal concrete cover
 H = height of Isokorb®
 l_s = lap length

Example: Schöck Isokorb® type K50-CV35
 $h_d = 180$ mm, CV = 35 mm, $d_s = 8$ mm,
 $c_i = 30$ mm
 max HV = $180 - 35 - 8 - 30 = 107$ mm

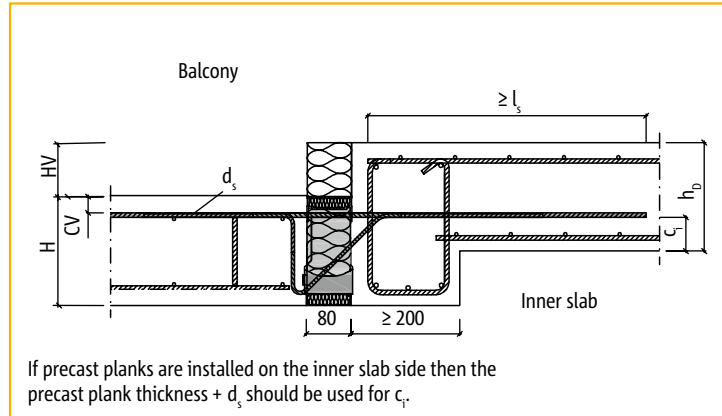

Schöck Isokorb® type K-CV35 (standard element)

- Link reinforcement required for deflection of tensile forces on the inner slab side (upper element length l_s). Calculation of the link reinforcement for cantilever moment and transverse force of the balcony slab.
- Recommendation: Inner slab joist width ≥ 200 mm
- Lap splice design on the balcony side to be implemented in accordance with page 38.
- Information about deflection - see pages 41.
- Refer to pages 34 - 35 for the calculation table.

Downstand element Schöck Isokorb® type K-HV-CV35

If the condition $HV \leq h_d - CV - d_s - c_i$ is not met, then the connection can be implemented with the

Schöck Isokorb® types K-HV10-CV35 for a vertical offset of 90 mm to 140 mm or K-HV15-CV35 for a vertical offset of 150 mm to 190 mm

Downstand beam width at least 220 mm

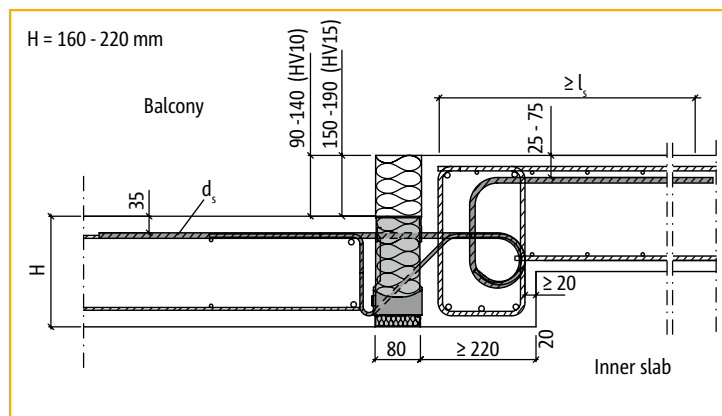

Schöck Isokorb® type K-HV-CV35

- Calculation of the link reinforcement for the cantilever moment and the shear force of the balcony slab.
- The lengths of the Schöck Isokorb® tension bars correspond to the required lap length l_s (acc. to EN 1992-1).
- Reinforcement of the connections to comply with page 61.
- The required transverse reinforcement in the overlapping area is to be calculated and verified in accordance with EN 1992-1, 8.7.2.
- Information about deflection and calculation table - see pages 59 - 60.

Schöck Isokorb® type K-BH

Connection to a step up balcony/Notes

Upstand element Schöck Isokorb® type K-BH-CV35

Schöck Isokorb® types **K-BH10-CV35**
 K-BH15-CV35

**Upstand beam width
at least 220 mm**

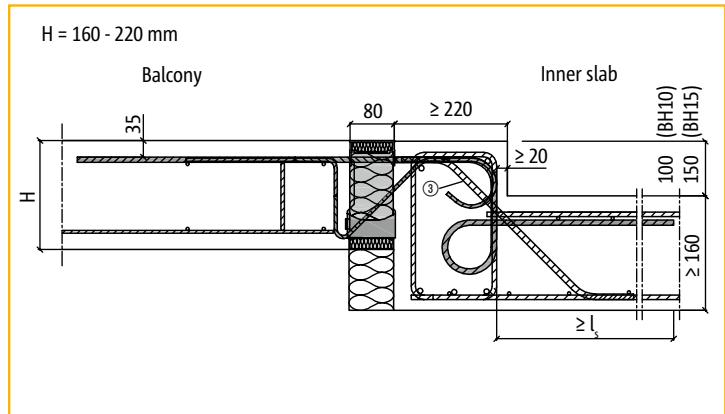

Schöck Isokorb® type K-BH-CV35

- Calculation of the link reinforcement for the cantilever moment and the shear force of the balcony slab.
- The lengths of the Schöck Isokorb® tension bars correspond to the required lap length l_s (acc. to EN 1992-1).
- Reinforcement of the connections to comply with page 62.
- The required transverse reinforcement in the overlapping area is to be calculated and verified in accordance with EN 1992-1, 8.7.2.
- Non-structural inclined reinforcement A_{ss} (item ④) - see page 62.
- Information about deflection and capacity table - see pages 59 - 60.

TE

K-HV
K-BH
K-WO
K-WU

Reinforced concrete-to-
reinforced concrete

Schöck Isokorb® type K-WO, K-WU

Connection to reinforced concrete walls

Connection with Schöck Isokorb® type K-WO-CV35 (rebars bent upwards)

TE

K-HV
K-BH
K-WO
K-WU

**Wall thickness
minimum 220 mm**

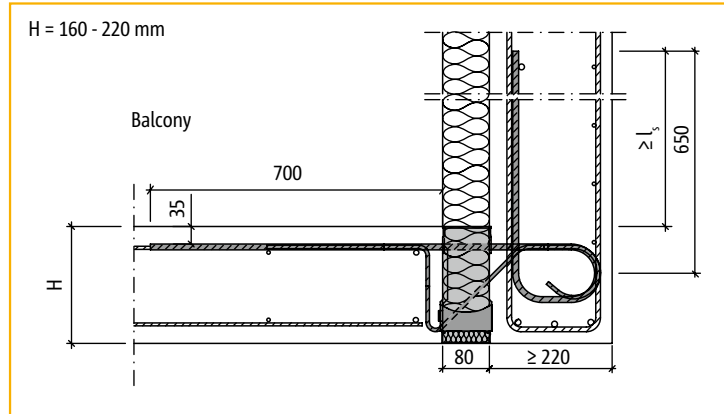

Schöck Isokorb® type K-WO-CV35

- The lengths of the Schöck Isokorb® tension bars correspond to the required lap length l_s (acc. to EN 1992-1).
- Lap splice design on the balcony side to be implemented in accordance with page 63.
- The required transverse reinforcement in the overlapping area is to be calculated and verified in accordance with EN 1992-1, 8.7.2.
- Elements for wall thicknesses < 220 mm available on request.
- Refer to page 59 for the capacity table.

Connection with Schöck Isokorb® type K-WU-CV35 (rebars bent downwards)

**Wall thickness
minimum 220 mm**

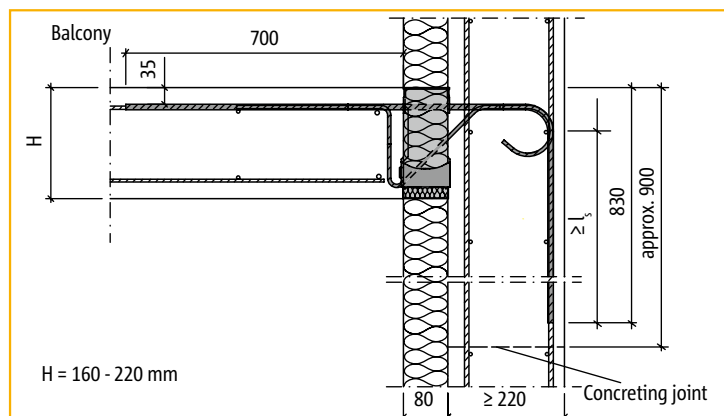

Schöck Isokorb® type K-WU-CV35

- The lengths of the Schöck Isokorb® tension bars correspond to the required lap length l_s (acc. to EN 1992-1).
- Lap splice reinforcement on the balcony side to be implemented in accordance with page 63.
- The required transverse reinforcement in the overlapping area is to be calculated and verified in accordance with EN 1992-1, 8.7.2.
- Elements for wall thicknesses < 220 mm available on request.
- Refer to page 59 for the capacity table.

Schöck Isokorb® type K-HV, K-BH, K-WO, K-WU

Product description/Capacity tables/Notes

Schöck Isokorb® type			K20-HV10/15 K20-BH10/15 K20-WO/WU	K30-HV10/15 K30-BH10/15 K30-WO/WU	K50-HV10/15 K50-BH10/15 K50-WO/WU	K60-HV10/15 K60-BH10/15 K60-WO/WU	
Design values for	Concrete cover CV [mm]		Concrete grade ≥ C25/30				
	CV30	CV35	CV50	Moment capacity m_{Rd} [kNm/m]			
Height of Schöck Isokorb® H [mm]		160		-14.0	-19.6	-28.0	-36.4
	160		180	-14.9	-20.8	-29.7	-38.6
		170		-15.7	-22.0	-31.4	-40.8
	170		190	-16.6	-23.2	-33.1	-43.0
		180		-17.4	-24.4	-34.8	-45.3
	180		200	-18.3	-25.6	-36.5	-47.5
		190		-19.1	-26.8	-38.3	-49.7
	190		210	-20.0	-28.0	-40.0	-51.9
		200		-20.8	-29.2	-41.7	-54.2
	200		220	-21.7	-30.4	-43.4	-56.4
		210		-22.5	-31.6	-45.1	-58.6
	210		230	-23.4	-32.8	-46.8	-60.8
	220		-24.2	-33.9	-48.5	-63.0	
220			-25.1	-35.1	-50.2	-65.3	
Shear force variants			Shear force capacity v_{Rd} [kN/m]				
			+28.0	+42.0	+42.0	+49.8	

HTE

K-HV
K-BH
K-WO
K-WU

Reinforced concrete-to-reinforced concrete

Product description	Isokorb® length [m]	1,00	1,00	1,00	1,00
	Tension bars	5 ϕ 10	7 ϕ 10	10 ϕ 10	13 ϕ 10
	Shear force variant	4 ϕ 6	6 ϕ 6	6 ϕ 6	7 ϕ 8
	Pressure bearings	5	7	10	16
	Special hoops	-	-	-	4

For the limitation of flexural slenderness, we advise the following maximum projection lengths $\max l_k$ [m]:

Concrete cover of tension bars	$\max l_k$ at height of Schöck Isokorb® H [mm]						
	160	170	180	190	200	210	220
CV = 30 mm	1.81	1.95	2.10	2.25	2.39	2.54	2.68
CV = 35 mm	1.74	1.88	2.03	2.17	2.32	2.46	2.61
CV = 50 mm	-	-	1.81	1.95	2.10	2.25	2.39

Notes

- ▶ Concrete grade for outside components at least C32/40 (see page 28).
- ▶ The verification of the shear force in slabs has to be provided by the structural designer according to EC2 clause 6.9..
- ▶ In the case of component geometries according to pages 56 to 58, it may be necessary to install the Schöck Isokorb® prior to installation of the inner slab joist reinforcement or the suspended beam reinforcement.
- ▶ In the case of a combination of different concrete grades (e.g. balcony C32/40, inner slab C25/30), the weaker concrete is critical in terms of the Isokorb® calculations.

Schöck Isokorb® type K-HV, K-BH, K-WO, K-WU

Deflection/Example calculation/Notes

Deflection

The deflection factors shown in the table below result solely from the deformation of the Schöck Isokorb® under 100 % exploitation of the steel stress of $f_{yd} = 435 \text{ N/mm}^2$. The final precamber of the balcony slab formwork results from the calculation according to BS 8500 or EC 2, plus the precamber due to the Schöck Isokorb®.

TE

Deflection (p) due to Schöck Isokorb®

$$p = [\text{table value} \times l_k \times (m_{pd}/m_{Rd})] \times 10 \text{ [mm]}$$

l_k Length of projection [m]
 m_{pd} Appropriate bending moment for calculation of the deflection p due to Schöck Isokorb®. The load combination to be applied here can be determined by the structural analysis engineer.
 m_{Rd} Maximum rated moment of the Schöck Isokorb® type K-HV,-BH,-WO,-WU (see page 59).

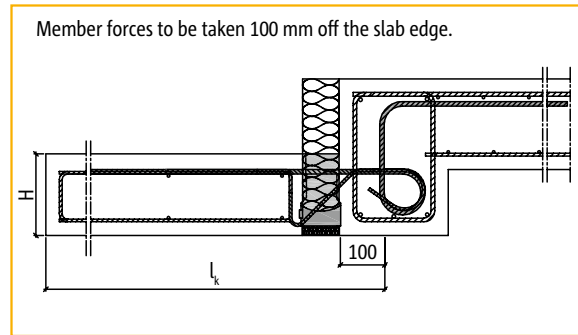

Schöck Isokorb® type		Deflection factor $\tan \alpha$ [%] at height of Isokorb® H [mm]						
		160	170	180	190	200	210	220
K-HV, -BH, -WO, -WU	CV30/CV35	1.0	0.9	0.8	0.8	0.7	0.6	0.6
K-HV, -BH, -WO, -WU	CV50	–	–	1.0	0.9	0.8	0.8	0.7

Example calculation for Schöck Isokorb®

Choice:

Concrete grade C32/40 for balcony
 Concrete grade C25/30 for inner slab (critical for the calculations)
 Concrete cover: CV = 35 mm for the Isokorb® tension bars

Geometry: Length of projection $l_k = 1.9 \text{ m}$
 Concrete slab thickness $h = 180 \text{ mm}$

Load assumptions: Balcony slab and finish $g = 5.7 \text{ kN/m}^2$
 Edge load (balustrade) $g_R = 1.5 \text{ kN/m}$
 Live load $q = 4.0 \text{ kN/m}^2$

$$m_{Ed} = -[(\gamma_G \times g + \gamma_Q \times q) \times l_k^2/2 + \gamma_G \times g_R \times l_k]$$

$$m_{Ed} = -[(1.35 \times 5.7 + 1.5 \times 4.0) \times 1.9^2/2 + 1.35 \times 1.5 \times 1.9]$$

$$= -28.6 \text{ kNm/m}$$

$$v_{Ed} = (\gamma_G \times g + \gamma_Q \times q) \times l_k + \gamma_G \times g_R$$

$$v_{Ed} = (1.35 \times 5.7 + 1.5 \times 4.0) \times 1.9 + 1.35 \times 1.5 = +28.1 \text{ kN/m}$$

Choice: Schöck Isokorb® type K50-HV10-CV35-H180

$$m_{Rd} = -34.8 \text{ kNm/m} \quad (\text{see page 59}) > m_{Ed}$$

$$v_{Rd} = +42.0 \text{ kN/m} \quad (\text{see page 59}) > v_{Ed}$$

$$\tan \alpha = 0.8 \% \quad (\text{see table above})$$

Chosen load combination for deflection due to Schöck Isokorb®: $g + q/2$

$$m_{pd} = -[(\gamma_G \times g + \gamma_Q \times q/2) \times l_k^2/2 + \gamma_G \times g_R \times l_k]$$

$$m_{pd} = -[(1.35 \times 5.7 + 1.5 \times 4.0/2) \times 1.9^2/2 + 1.35 \times 1.5 \times 1.9]$$

$$= -23.2 \text{ kNm/m}$$

$$p = [\text{table value} \times l_k \times (m_{pd}/m_{Rd})] \times 10 \text{ [mm]}$$

$$p = [0.8 \times 1.9 \times (23.2/34.8)] \times 10 = 10 \text{ mm}$$

Notes

- ▶ In the case of a combination of different concrete grades (e.g. balcony C32/40, inner slab C25/30), the weaker concrete is critical in terms of the Isokorb® calculations.
- ▶ The verification of the shear force in slabs has to be provided by the structural designer according to EC2 clause 6.9..

Schöck Isokorb® type K-HV

Lap splice design

On-site lap splice reinforcement for Schöck Isokorb® type K-HV

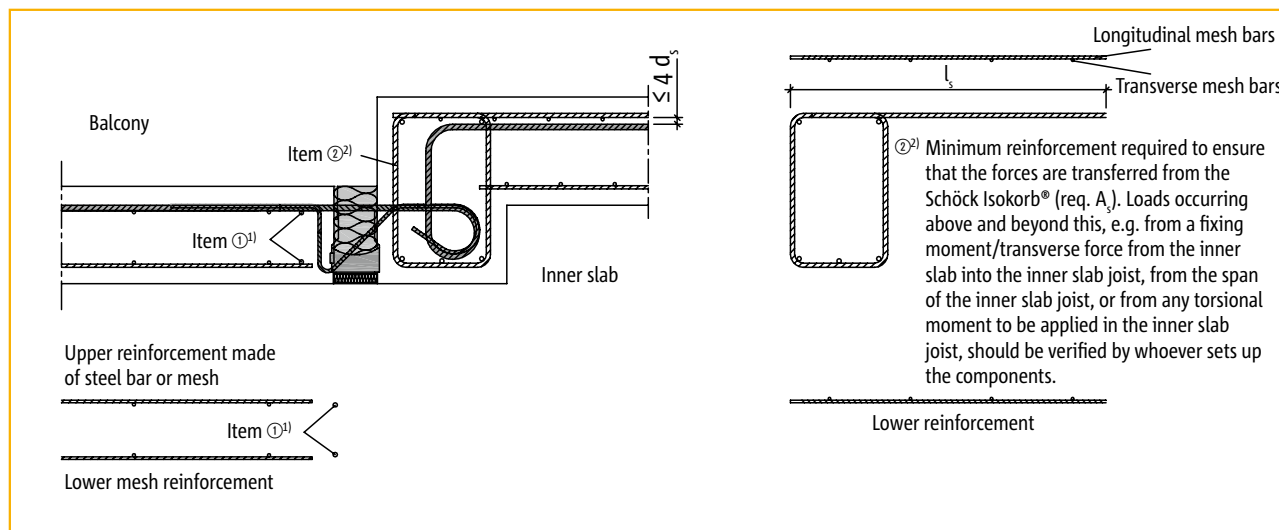

Section

Schöck Isokorb® type		K20-HV	K30-HV	K50-HV	K60-HV
Balcony	Tension bars	Main balcony reinforcement according to the structural engineer's details or with reference to page 38.			
	Item ① Straight rebar	2 no. T8	2 no. T8	2 no. T8	2 no. T8
Downstand beam	Item ② Link ²⁾	min.req. T10@100c/c	min.req. T12@100c/c	min.req. T14@100c/c	min.req. T14@70c/c
	Lap length	$l_s \geq 570$ mm	$l_s \geq 680$ mm	$l_s \geq 790$ mm	$l_s \geq 790$ mm

¹⁾ The last transverse bar of the mesh must be positioned as closely as possible to the pressure bearing. Otherwise T8 mm steel rebars should be fitted there.

²⁾ Length of connective rebars item ② has to be defined by the structural engineer. It depends on the bond action between structural screed and hollowcore units.

HTE

K-HV
K-BH
K-WO
K-WU

Reinforced concrete-to-reinforced concrete

Schöck Isokorb® type K-BH

Lap splice design

On-site lap splice reinforcement for Schöck Isokorb® type K-BH

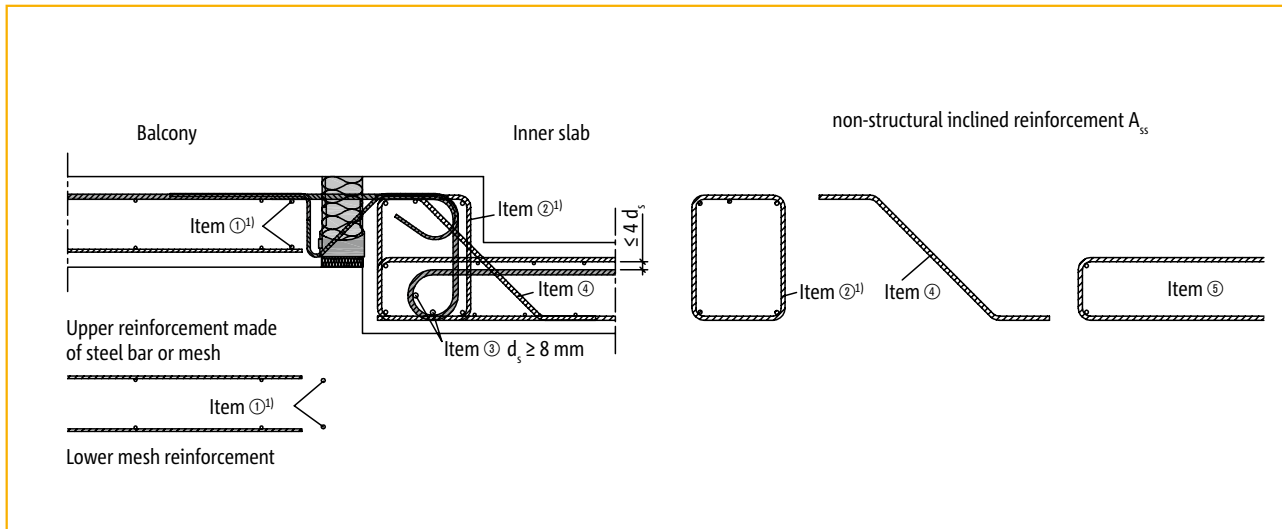

Section

Schöck Isokorb® type		K20-BH	K30-BH	K50-BH	K60-BH
Balcony	Tension bars	Main balcony reinforcement according to the structural engineer's details or with reference to page 38.			
	Item ① Straight rebar	2 no. T8	2 no. T8	2 no. T8	2 no. T8
Upstand beam	Item ② Link ¹⁾	min.req. T10@100c/c	min.req. T12@100c/c	min.req. T14@100c/c	min.req. T14@70c/c
	Item ③ Straight rebar	2 no. T8	2 no. T8	2 no. T8	2 no. T8
	Item ④ Z-shaped rebar	T6@200 c/c	T6@200 c/c	T6@200 c/c	min.req. T10@140 c/c

Notes

- ▶ The last transverse bar of the mesh must be positioned as closely as possible to the pressure bearing. Otherwise T8 mm steel rebars should be fitted there.
- ▶ Items ②,④,⑤ have to be defined by the structural engineer.
- ▶ U-bars/hooks required if the upstand beam width is > 220 mm or if there is no overlap between the Schöck tension bars and the upper reinforcement of the inner slab.

Schöck Isokorb® Typ K-WO, K-WU

Lap splice design

On-site lap splice reinforcement for Schöck Isokorb® type K-WO

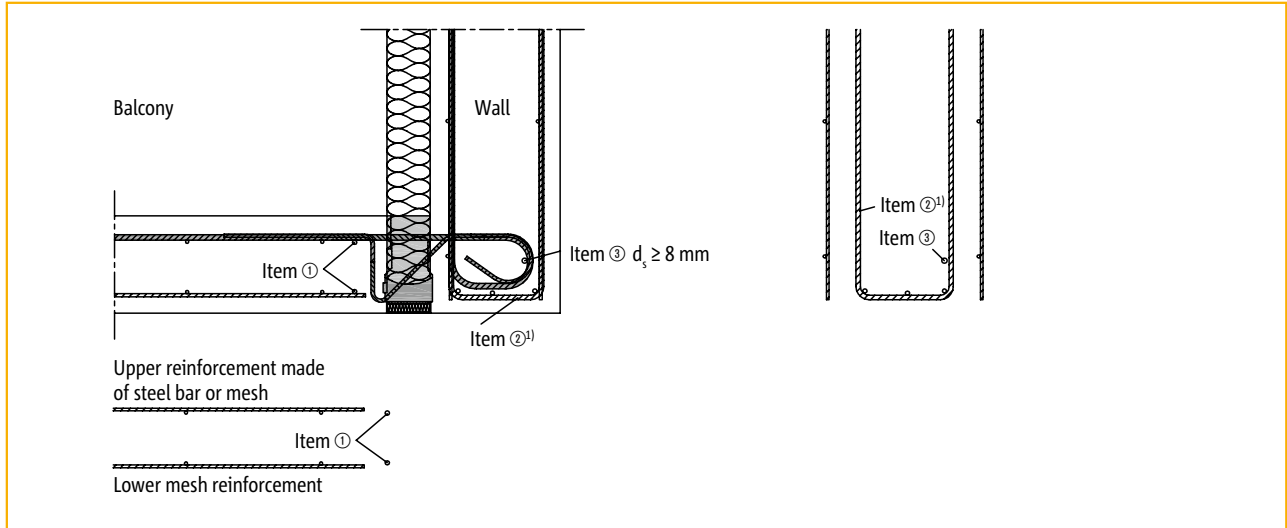

Section

Schöck Isokorb® type		K20-WO	K30-WO	K50-WO	K60-WO
Balcony	Tension bars	Main balcony reinforcement according to the structural engineer's details or with reference to page 38.			
	Item ① Straight rebar	2 no. T8	2 no. T8	2 no. T8	2 no. T8
At outer face of wall	Item ② U-bar ¹⁾	min.req. T8@100c/c	min.req. T10@100c/c	min.req. T12@100c/c	min.req. T14@100c/c
	Item ③ Straight rebar	1 no. T8	1 no. T8	1 no. T8	1 no. T8

On-site lap splice reinforcement for Schöck Isokorb® type K-WU

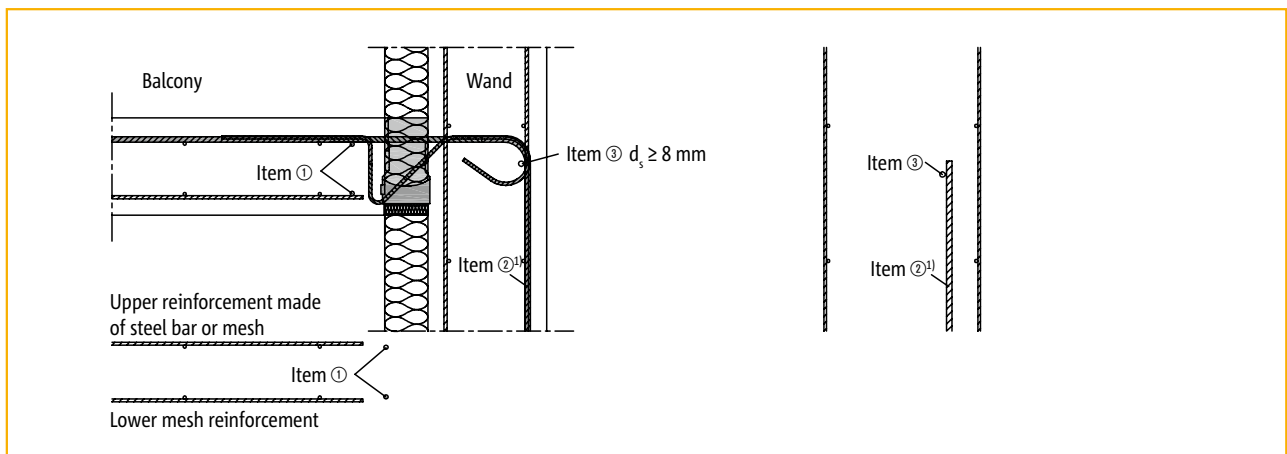

Section

Schöck Isokorb® type		K20-WU	K30-WU	K50-WU	K60-WU
Balcony	Tension bars	Main balcony reinforcement according to the structural engineer's details or with reference to page 38.			
	Pos. ① Straight rebar	2 no. T8	2 no. T8	2 no. T8	2 no. T8
At inner face of wall	Pos. ② Straight rebar ¹⁾	min.req. T8@100c/c	min.req. T10@100c/c	min.req. T12@100c/c	min.req. T14@100c/c
	Pos. ③ Straight rebar	1 no. T8	1 no. T8	1 no. T8	1 no. T8

¹⁾ Required reinforcement guaranteeing the load transfer via Schöck Isokorb® into the wall based on 100% exploitation of the capacity; the ratio of m_{Ed}/m_{Rd} can be taken into account.

HTE

K-HV
K-BH
K-WO
K-WU

Reinforced concrete-to-reinforced concrete

Schöck Isokorb® type K-HV

Method statement

TE

K-HV
K-BH
K-WO
K-WU

Reinforced concrete-to-reinforced concrete

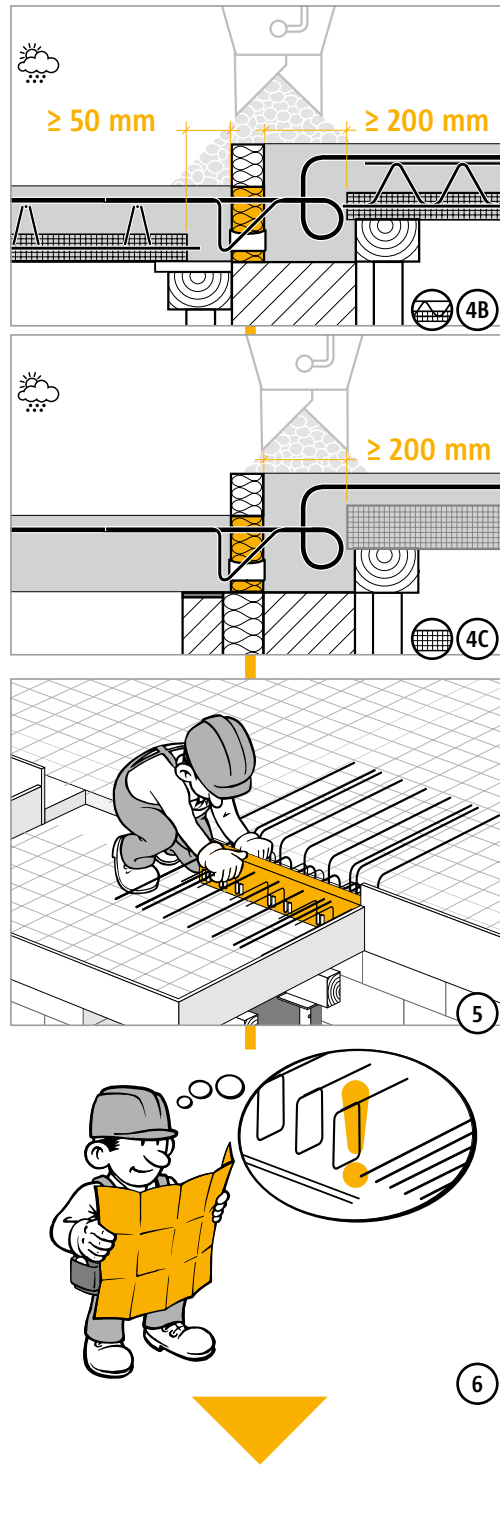
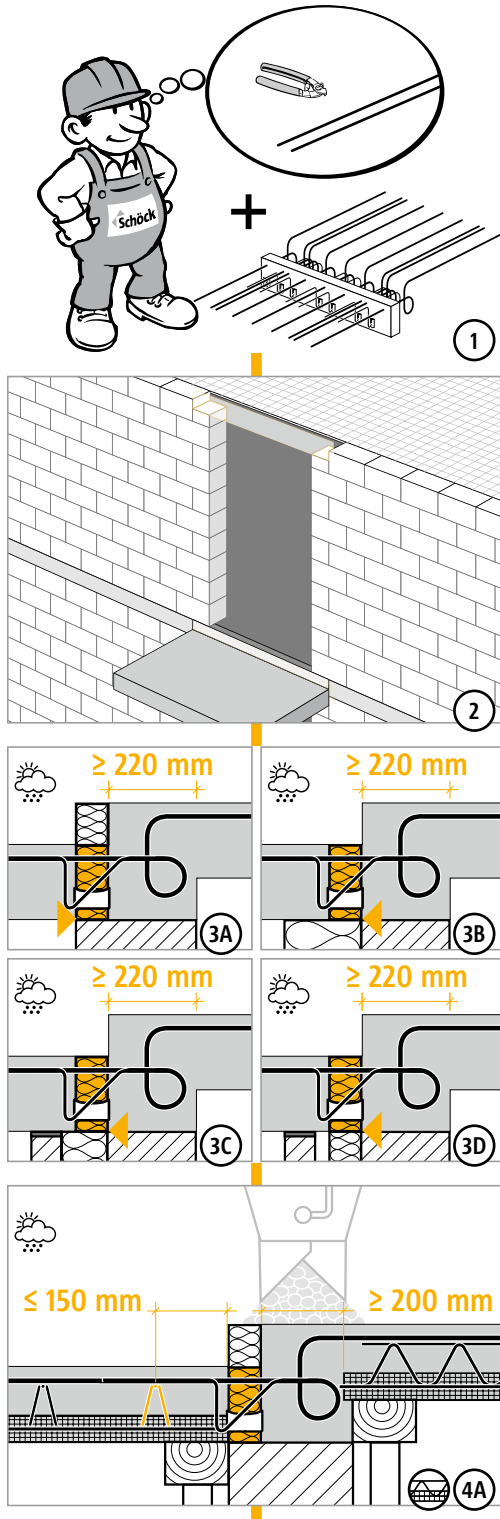

Schöck Isokorb® type K-HV

Method statement

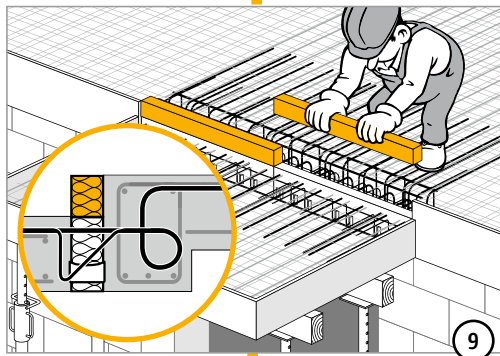
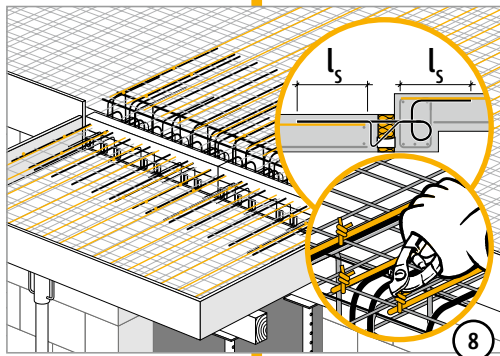
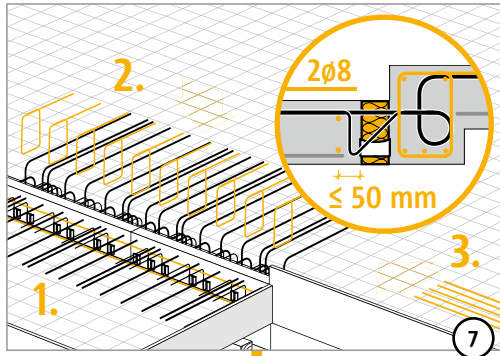

HTE

K-HV
K-BH
K-WO
K-WU

Reinforced concrete-to-reinforced concrete

Further method statements for type K-BH, K-WO, K-WU can be found at: www.schoeck.co.uk

Schöck Isokorb® type K-HV, K-BH, K-WO, K-WU

Check list



- Have the member forces on the Isokorb® connection been determined at the design level?
- Was the cantilevered system length used in the process (Member forces to be taken 100 mm off the slab edge.)?
- Have the concrete cover and the appropriate concrete grade been taken into consideration according to the building regulations (see page 23)
- In case of precast planks will be used, is sufficient bond action between reinforced structural screed and precast planks guaranteed?
- Have the maximum permitted distances between expansion joints (= expansion joint spacing) been taken into account?
- Has the required on-site lap splice reinforcement been defined?
- Do the calculations of the deformation of the overall structure take into account the additional deflection due to the Schöck Isokorb®?
- Has the drainage direction been taken into account in the resulting precamber specification of the balcony framework?
- Has the relevant bearing limit of the slab been checked for Shear forces according to EC2 clause 6.9.. ?
- In case of corner a balcony, have the minimum slab thickness (≥ 180 mm) and the required 2nd layer (CV50) been taken into account?
- In the case of a connection to an upstand or downstand beam, or a connection to a wall, is the required component geometry present?
- Have the fire safety requirements been clarified, and are they reflected in the chosen type designation (-F90)?
- In the case of F90 elements, has the increased minimum slab thickness been taken into account (type Q, type V)?

TE

K-HV
K-BH
K-WO
K-WU

Reinforced concrete-to-reinforced concrete

Schöck Isokorb® type Q

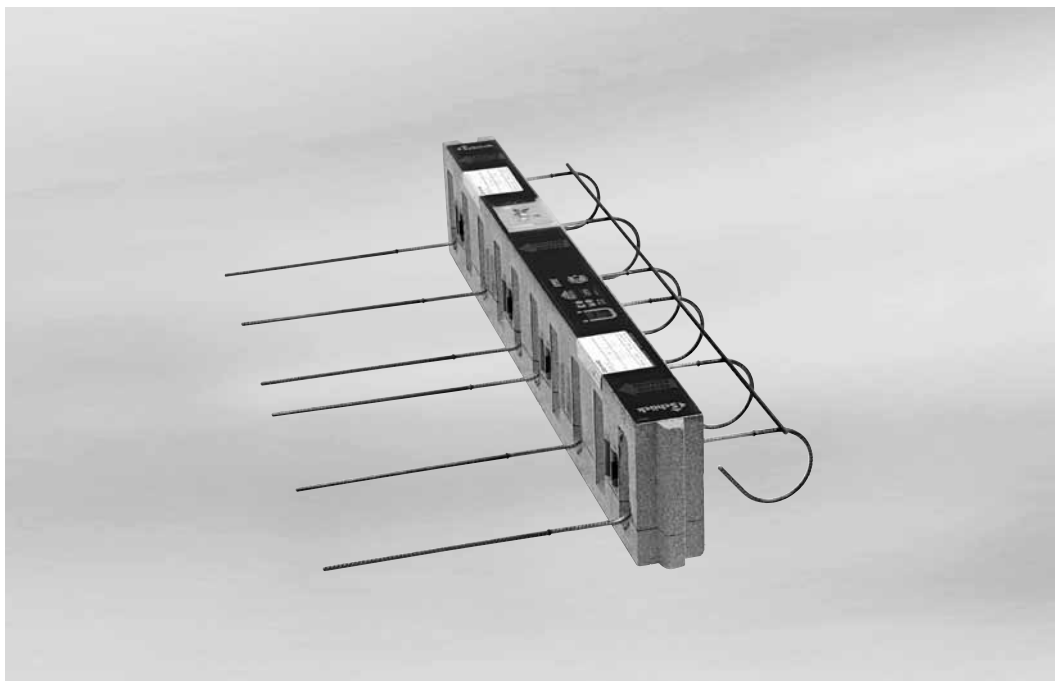

Schöck Isokorb® type Q

Q

Reinforced concrete-to-reinforced concrete

Contents	Page
Examples of element arrangements and cross-sections	68
Capacity tables and cross-sections	69 -71
Plan views	72
Moments resulting from excentric connections	73
Examples of application	74 - 75
On-site reinforcement	76
Expansion joint spacing/Notes	77
Method statement	78 - 79
Check list	80
Fire resistance	16 - 17

Schöck Isokorb® type Q

Examples of element arrangements and cross-sections

Q

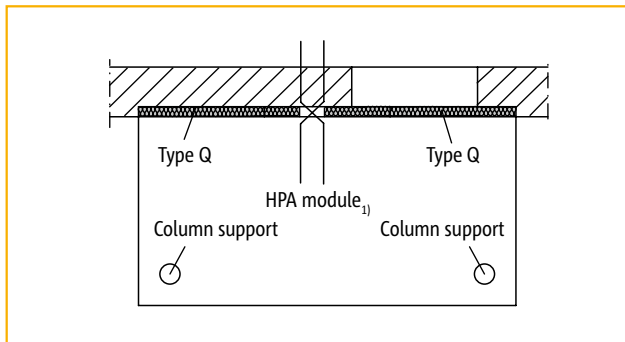

Figure 1: Balcony with column support

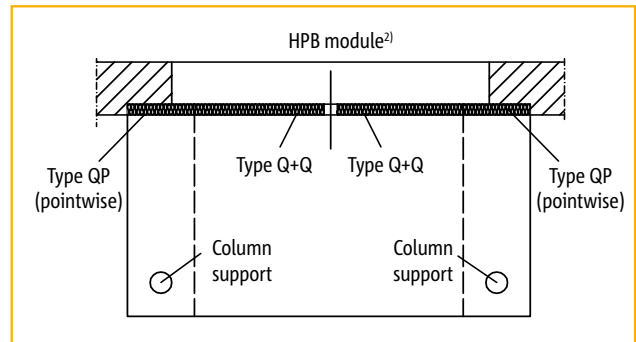

Figure 2: Balcony with column support and inner slab support with diverse spring stiffnesses

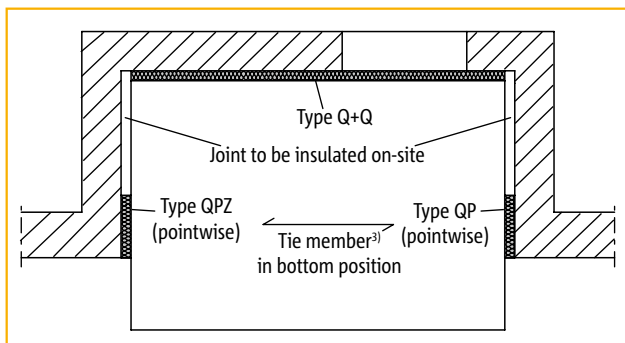

Figure 3: Loggia, mounted on three sides, with tie member³⁾ and shear forces causing lift-up

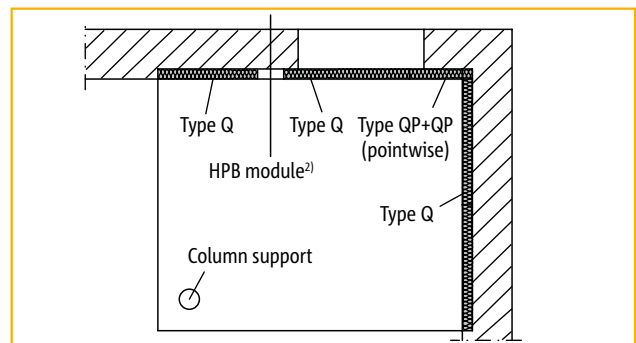

Figure 4: Balcony, supported on two sides, with column support, shear forces causing lift-up

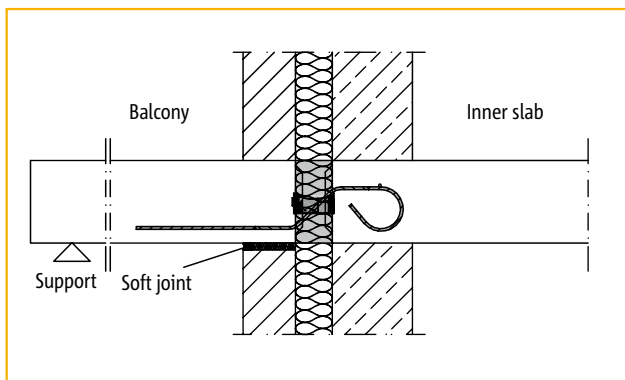

Figure 5: Cavity wall with a balcony at inner slab level

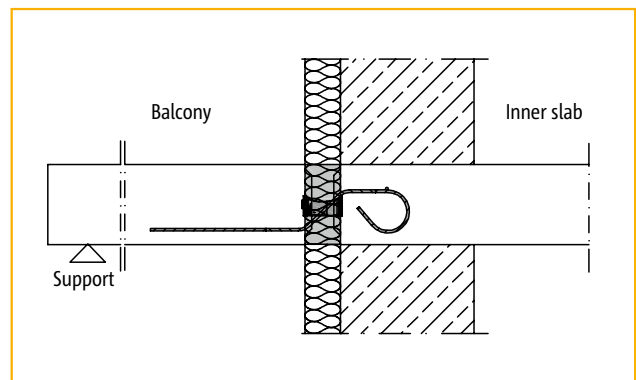

Figure 6: Brickwork with external insulation and a balcony at inner slab level

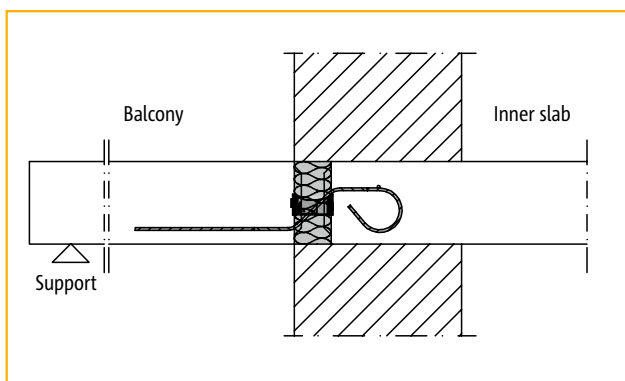

Figure 7: Single-leaf brickwork with a balcony at inner slab level

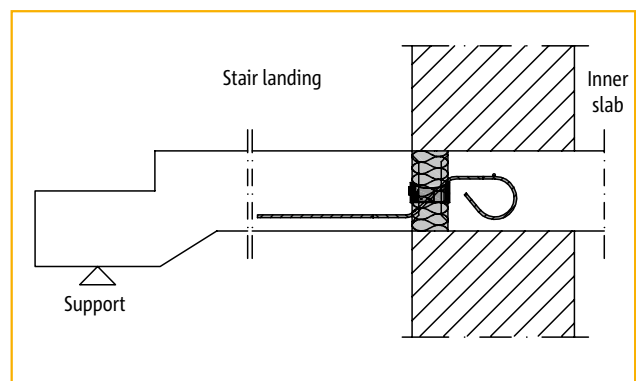

Figure 8: Single-leaf brickwork with stair landing

¹⁾ If horizontal forces occur parallel to the external wall, additional Schöck HPA modules should be installed (see page 91 - 95).

²⁾ In the case of horizontal tensile forces perpendicular to the external wall which are greater than the present shear forces, additional Schöck HPB modules should be installed (see pages 91 - 95).

³⁾ Loggia with tie member - see notes on page 75.

Schöck Isokorb® type Q, QP

Capacity tables for C25/30 and cross-sections

Schöck Isokorb® type Q for the transfer of positive shear forces - continuous bearing

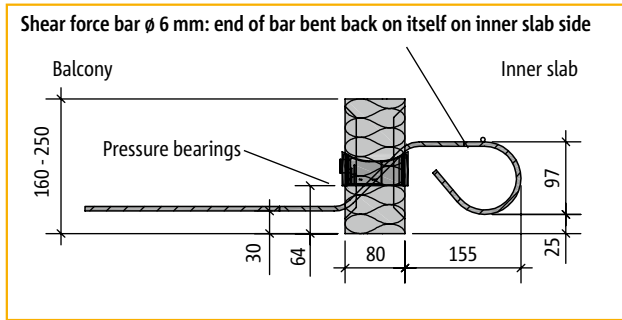

Cross-section: Schöck Isokorb® type Q10 to type Q50 at F0

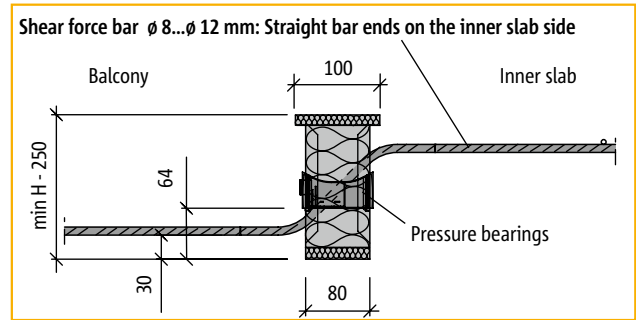

Cross-section: Schöck Isokorb® type Q70 to Q110 at F90

Schöck Isokorb® type	Q10	Q20	Q30	Q40	Q50	Q70	Q80	Q90	Q100	Q110
Design values for ¹⁾	Shear force capacity v_{Rd} [kN/m]									
Concrete grade C25/30	+34.8	+43.5	+52.2	+69.5	+86.9	+92.7	+111.1	+133.3	+173.3	+206.4
Isokorb® length [m]	1.00	1.00	1.00	1.00	1.00	1.00	1.00	1.00	1.00	1.00
Shear force bar	4 ϕ 6	5 ϕ 6	6 ϕ 6	8 ϕ 6	10 ϕ 6	6 ϕ 8	5 ϕ 10	6 ϕ 10	5 ϕ 12	6 ϕ 12
Pressure bearings	4	4	4	4	4	4	4	4	6	6
min H at F 0 [mm]	160	160	160	160	160	160	170	170	180	180
min H at F 90 [mm]	160	160	160	160	160	160	180	180	190	190

Schöck Isokorb® type QP for the transfer of positive shear forces - focused bearing

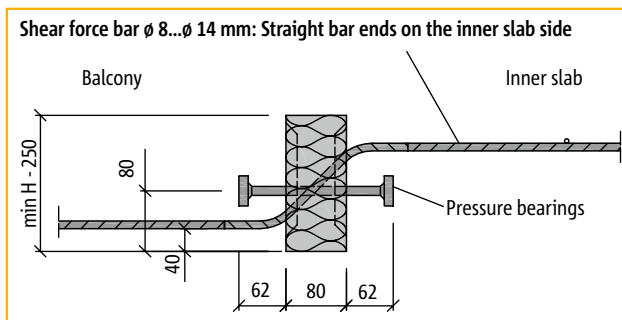

Cross-section: Schöck Isokorb® type QP10 up to type QP90 at F0

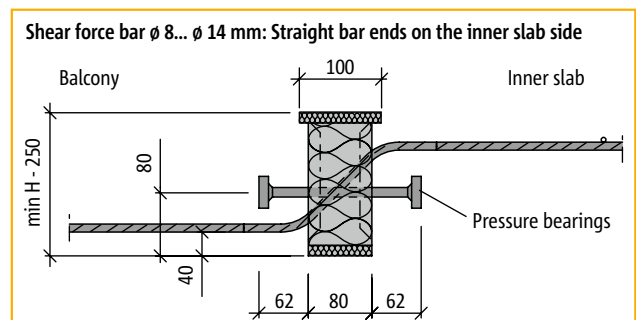

Cross-section: Schöck Isokorb® type QP10 up to type QP90 with min H F90

Schöck Isokorb® type	QP10	QP20	QP30	QP40	QP50	QP60	QP70	QP80	QP90
Design values for ¹⁾	Shear force capacity V_{Rd} [kN]								
Concrete grade C25/30	+30.9	+46.4	+61.8	+44.8	+65.4	+65.4	+98.6	+85.9	+128.9
Isokorb® length [mm]	300	400	500	300	400	300	400	300	400
Shear force bar	2 ϕ 8	3 ϕ 8	4 ϕ 8	2 ϕ 10	3 ϕ 10	2 ϕ 12	3 ϕ 12	2 ϕ 14	3 ϕ 14
Pressure bearings	1 ϕ 10	2 ϕ 10	2 ϕ 10	1 ϕ 12	2 ϕ 10	2 ϕ 10	2 ϕ 12	2 ϕ 12	3 ϕ 12
min H at F 0 [mm]	170	170	170	180	180	190	190	200	200
min H at F 90 [mm]	180	180	180	190	190	200	200	210	210

¹⁾ A verification of the shear force capacity of the slabs has to be done by the structural engineer according to EC2 clause 6.9

Q

Reinforced concrete-to-reinforced concrete

Schöck Isokorb® type Q+Q, QP+QP

Capacity tables for C25/30 and cross-sections

Schöck Isokorb® Typ Q+Q for the transfer of positive and negative shear forces for continuous bearing

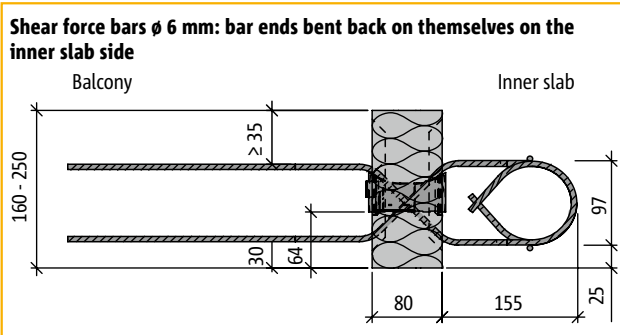

Cross-section: Schöck Isokorb® type Q10+Q10, type Q30+Q30 and type Q50+Q50

Schöck Isokorb® type	Q10+Q10	Q30+Q30	Q50+Q50	Q70+Q70 ¹⁾
Design values for ²⁾	Shear force capacity v_{Rd} [kN/m]			
Concrete grade C25/30	±34.8	±52.2	±86.9	±92.7
Isokorb® length [m]	1.00	1.00	1.00	1.00
Shear force bar	2 x 4 ϕ 6	2 x 6 ϕ 6	2 x 10 ϕ 6	2 x 6 ϕ 8 ¹⁾
Pressure bearings	4	4	4	4
min H at F 0 [mm]	160	160	160	160
min H at F 90 [mm]	160	160	160	160

Schöck Isokorb® Typ QP+QP for the transfer of positive and negative shear forces for focused bearing

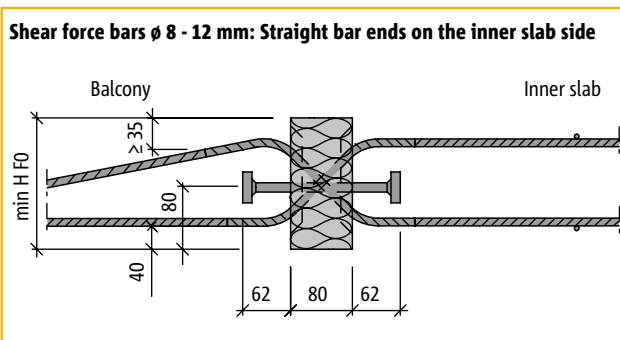

Cross-section: Schöck Isokorb® type QP10+QP10 to QP70+QP70 with min H F 0

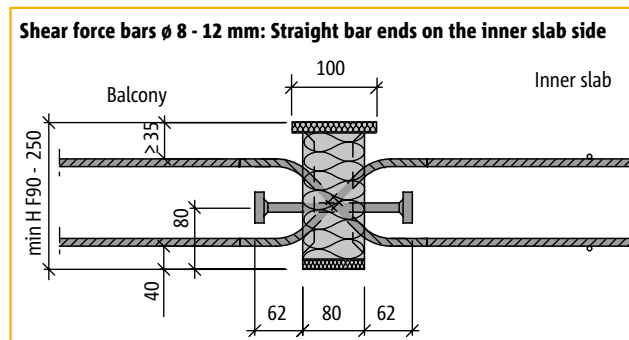

Cross-section: Schöck Isokorb® type QP10+QP10 to QP70+QP70 with min H F 90

Schöck Isokorb® type	QP10+QP10	QP40+QP40	QP60+QP60	QP70+QP70
Design values for ²⁾	Shear force capacity V_{Rd} [kN]			
Concrete grade C25/30	±30.9	±44.8	±65.4	±98.6
Isokorb® length [mm]	300	300	300	400
Shear force bar	2 x 2 ϕ 8	2 x 2 ϕ 10	2 x 2 ϕ 12	2 x 3 ϕ 12
Pressure bearings	1 ϕ 12	1 ϕ 12	2 ϕ 10	2 ϕ 12
min H at F 0 [mm]	170	180	190	190
min H at F 90 [mm]	180	190	200	200

¹⁾ bars are straight on the inner slab side

²⁾ The verification of the shear force in slabs has to be provided by the structural designer according to EC2 clause 6.9..

Schöck Isokorb® type QPZ

Capacity tables for C25/30 and cross-sections

Schöck Isokorb® Typ QPZ for the transfer of positive shear forces for focused bearing and restraint-free connections (see page 75)

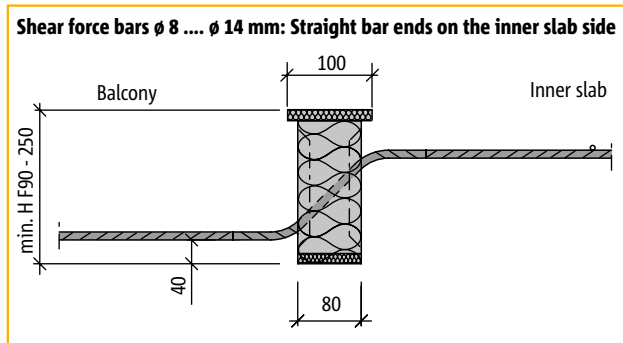

Cross-section: Schöck Isokorb® type QPZ10 to QPZ80

Schöck Isokorb® type	QPZ10	QPZ40	QPZ60	QPZ70	QPZ80
Design values for ²⁾	V_{Rd} [kN]				
Concrete grade C25/30	+30.9	+44.8	+65.4	+98.6	+85.9
Isokorb® length [mm]	300	300	300	400	300
Shear force bar	2 $\phi 8$	2 $\phi 10$	2 $\phi 12$	3 $\phi 12$	2 $\phi 14$
Pressure bearings	–	–	–	–	–
min H at F 0 [mm]	170	180	190	190	200
min H at F 90 [mm]	160	190	200	200	210

²⁾ The verification of the shear force in slabs has to be provided by the structural designer according to EC2 clause 6.9..

Schöck Isokorb® type Q, QP, QP+QP, QPZ

Plan views

Q

Reinforced concrete-to-reinforced concrete

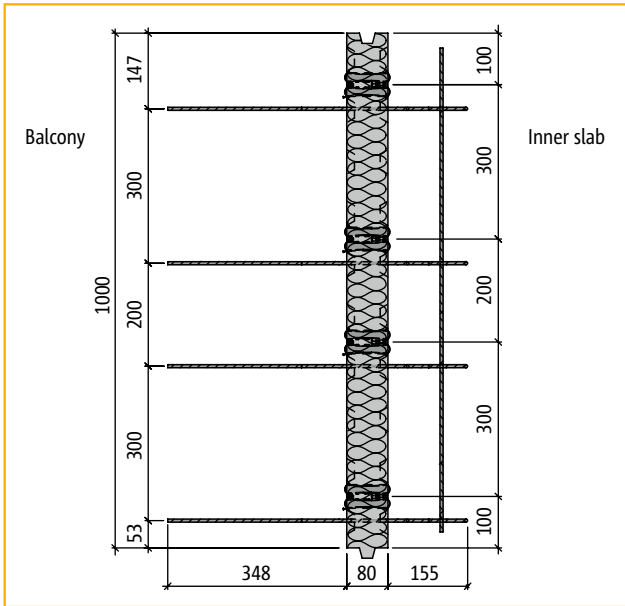

Plan view: Schöck Isokorb® type Q10

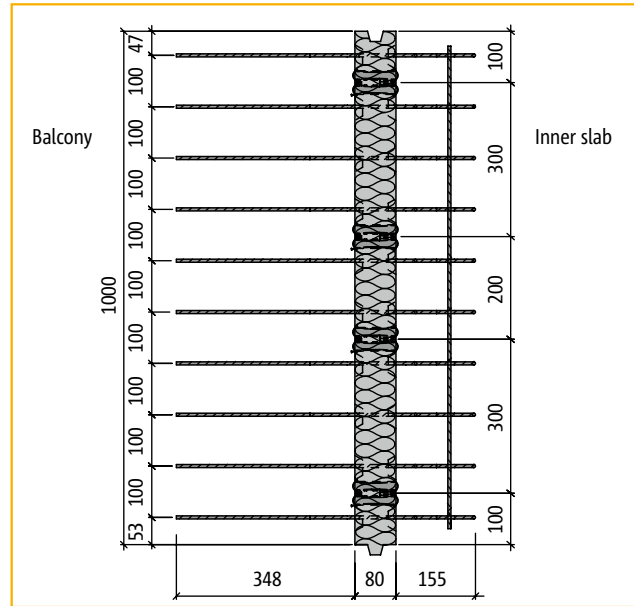

Plan view: Schöck Isokorb® type Q50

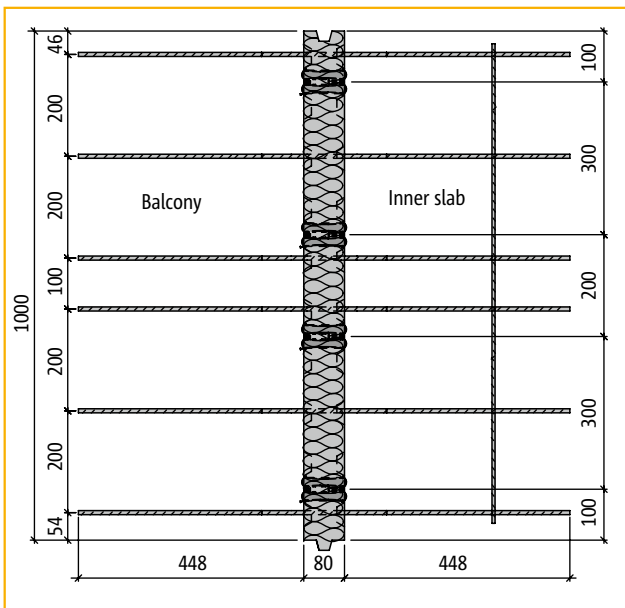

Plan view: Schöck Isokorb® type Q70

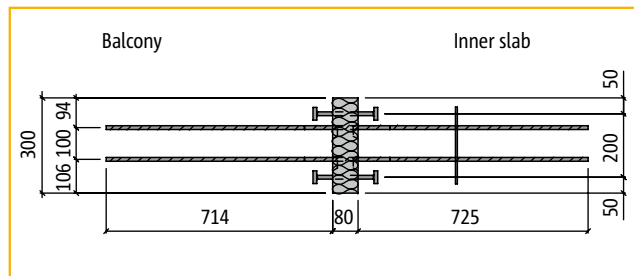

Plan view: Schöck Isokorb® type QP60

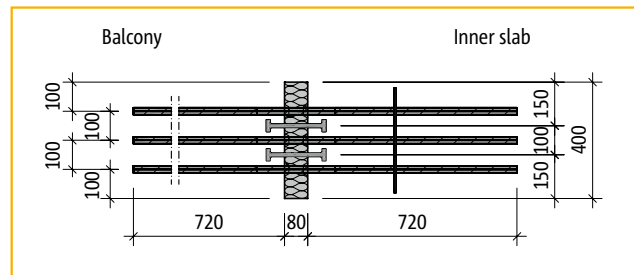

Plan view: Schöck Isokorb® type QP70+QP70

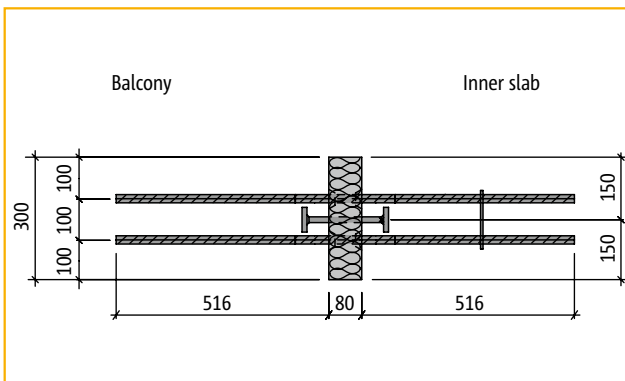

Plan view: Schöck Isokorb® type QP40+QP40

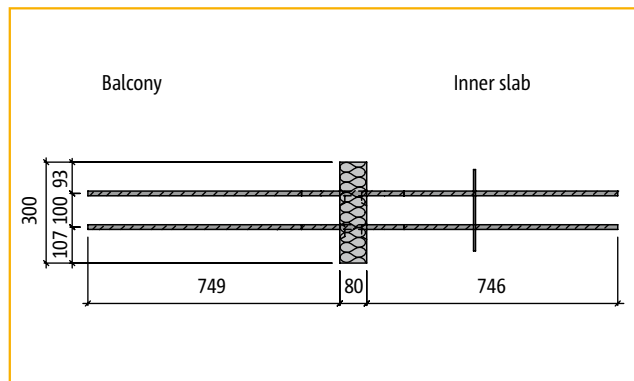

Plan view: Schöck Isokorb® type QPZ80 (Z= restraint-free)

Schöck Isokorb® type Q

Moments resulting from excentric connections

Moments from excentric connection

When calculating the connection reinforcement on both sides of the Schöck Isokorb® type Q, moments arising from excentric connections also need to be taken into account additionally. These moments should be added to the moments resulting from the planned load if both values have the same sign.

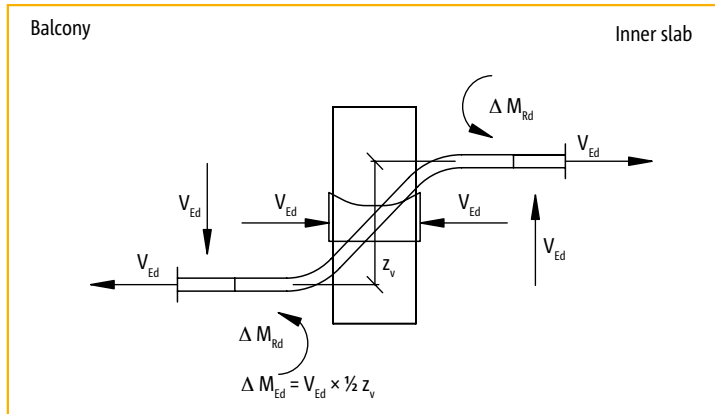

Schöck Isokorb® type	$\Delta M_{Rd}^{1)}$ [kNm/element]
Q10, Q10+Q10	2.43
Q20	3.04
Q30, Q30+Q30	3.65
Q40	4.87
Q50, Q50+Q50	6.08
Q70	6.49
Q80	7.77
Q90	9.33
Q100	12.13
Q110	14.45
QP10, QP10+QP10	2.16
QP20	3.25
QP30	4.33
QP40, QP40+QP40	3.11
QP50	4.66
QP60, QP60+QP60	4.85
QP70, QP70+QP70	7.28
QP80	5.81
QP90	8.72

Q

Reinforced concrete-to-reinforced concrete

¹⁾ with max. $z_v = 140$ mm

Schöck Isokorb® type Q

Examples of application

Q

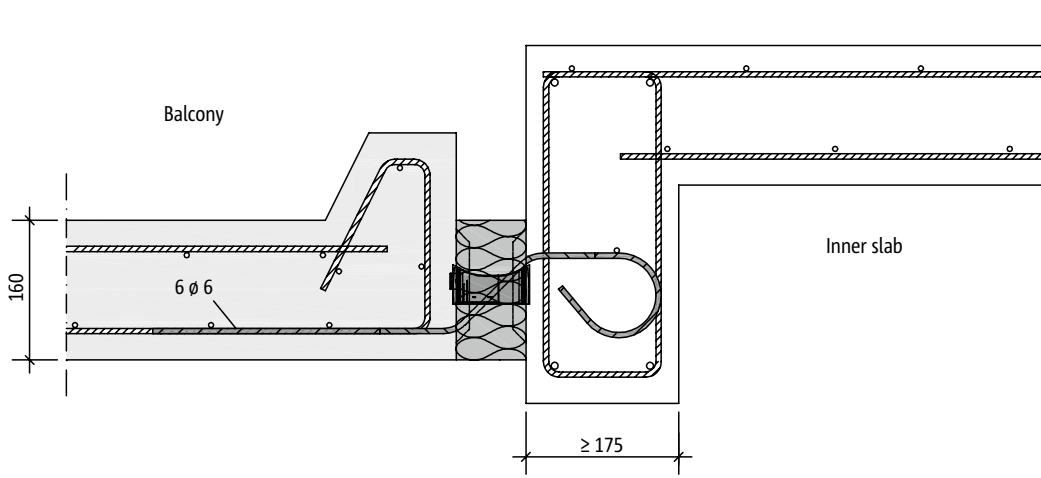

Figure 1: Cross-section of an "prefabricated balcony slab" installation with Schöck Isokorb® Typ Q30-H160

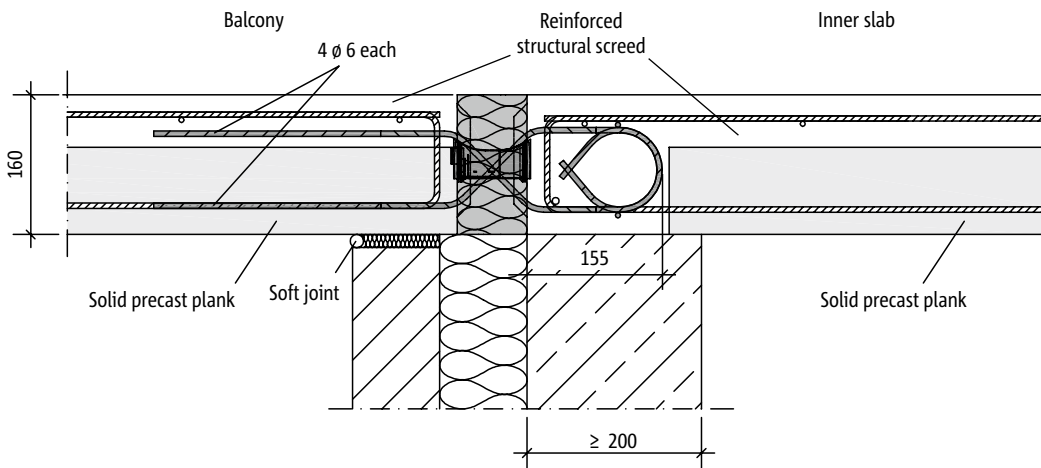

Figure 2: Cross-section of a "semi-precast balcony slab" installation with Schöck Isokorb® Typ Q10+Q10-H160

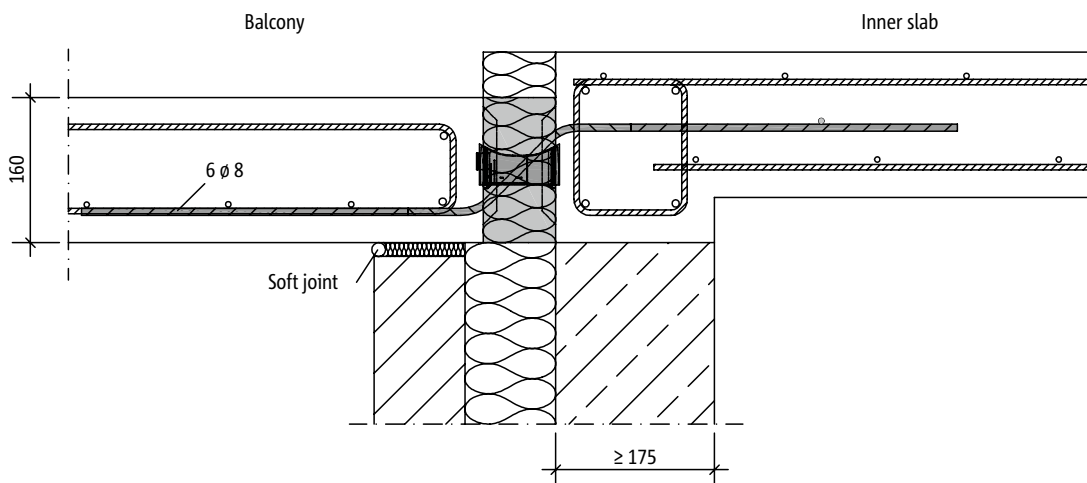

Figure 3: Cross-section of an installation with Schöck Isokorb® type Q70-H160

Reinforced concrete-to-reinforced concrete

Schöck Isokorb® type Q

Examples of application

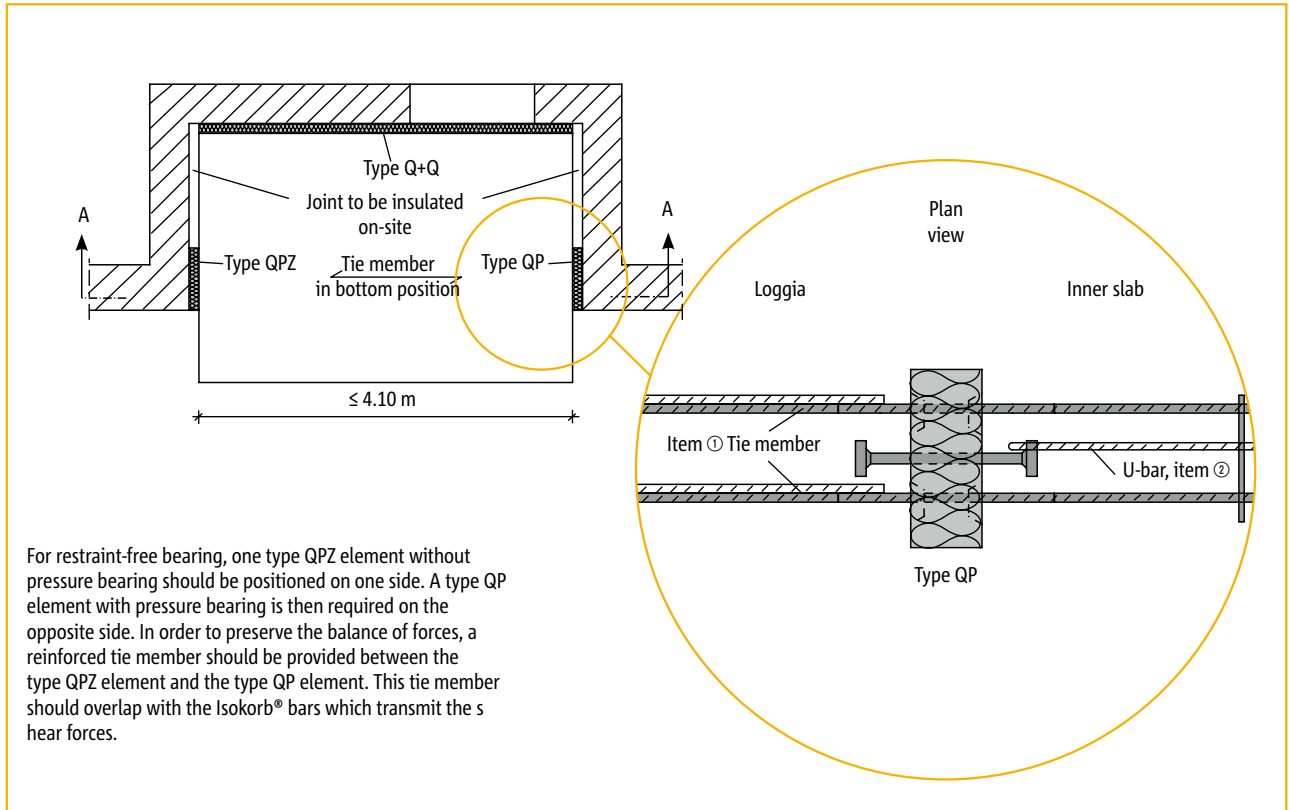

Figure 4: Loggia with bearing on three sides and with tie member

- ▶ Details on this page only show the requirements for a restraint-free bearing. The in any case required additional on-site connection reinforcement is shown on page 76.

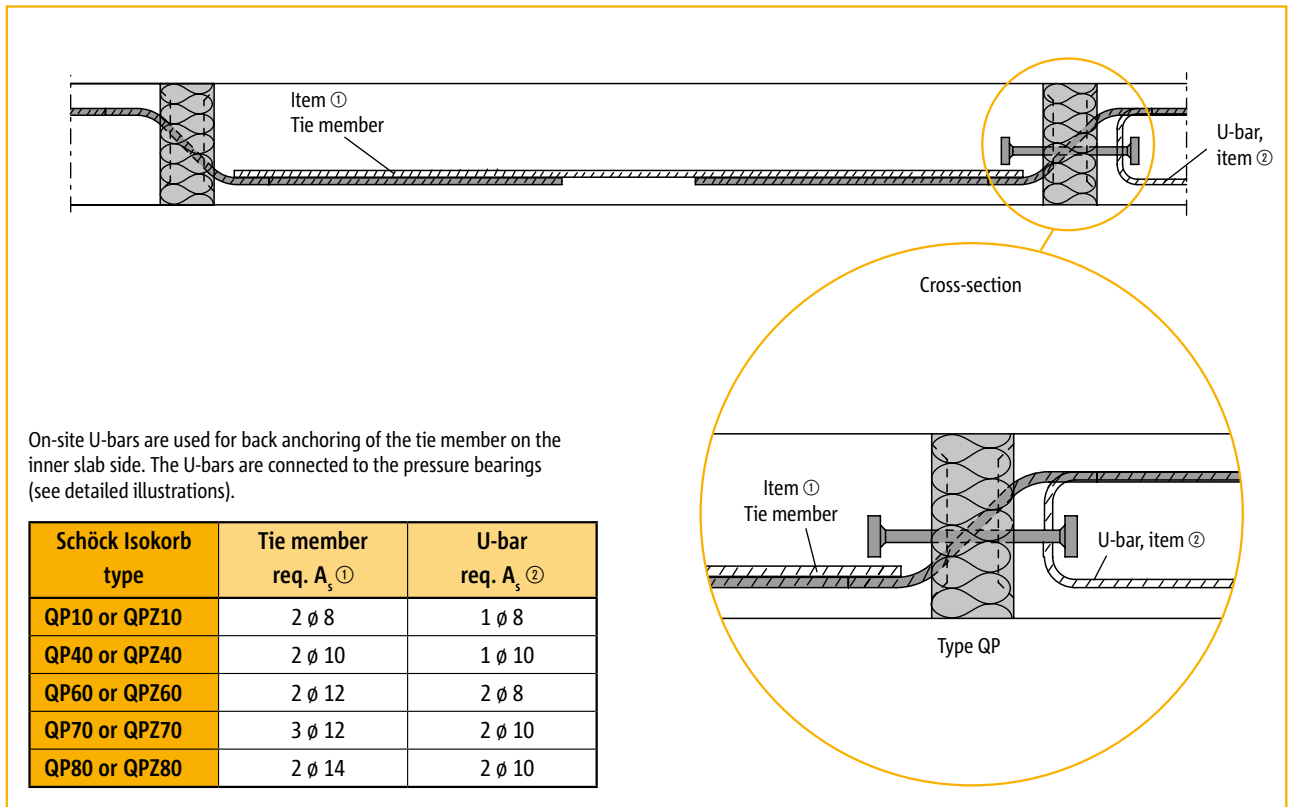

Figure 5: A-A section through the loggia

Q
Reinforced concrete-to-reinforced concrete

Schöck Isokorb® type Q

On-site reinforcement

Connection with U-bars

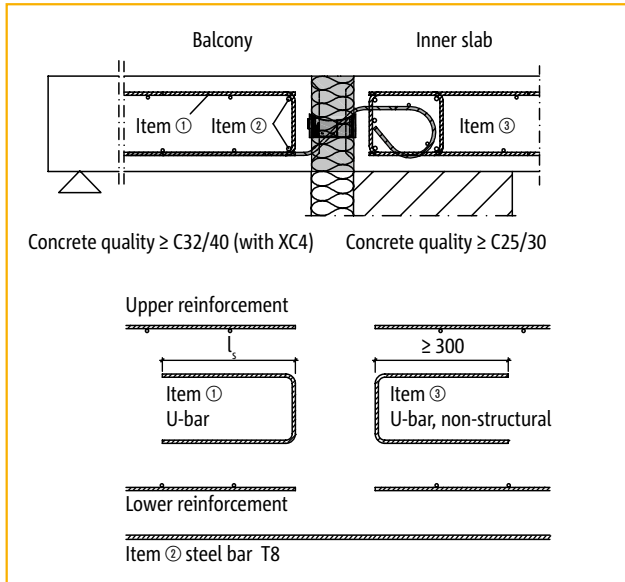

Schöck Isokorb® type	U-bar (item ①) req. a_s [mm ² /element]
Q10, Q10+Q10 ¹⁾	80
Q20	100
Q30, Q30+Q30 ¹⁾	120
Q40	160
Q50, Q50+Q50 ¹⁾	200
Q70	213
Q80	255
Q90	306
Q100	398
Q110	474
QP10, QP10+QP10 ¹⁾ , QPZ10 ²⁾	71
QP20	107
QP30	142
QP40, QP40+QP40 ¹⁾ , QPZ40 ²⁾	102
QP50	150
QP60, QP60+QP60 ¹⁾ , QPZ60	150
QP70, QP70+QP70	225
QP80, QPZ80 ²⁾	191
QP90	286

¹⁾ Instead of with item ③, types Q+Q and QP +QP should also be connected with items ① and ② on the inner slab side.

²⁾ Types QPZ for restraint-free connections (see page 82, figure 3) require a reinforced tie member in the bottom position. The required $A_{s,Tensile}$ should be chosen in accordance with page 75, Figure 5.

Schöck Isokorb® type Q

Expansion joint spacing/Notes

Expansion joint spacing

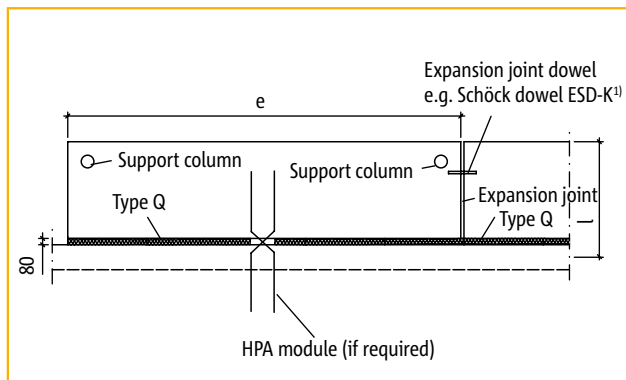

Figure 1: Layout of expansion joints for balcony slabs with a straight-edged connection

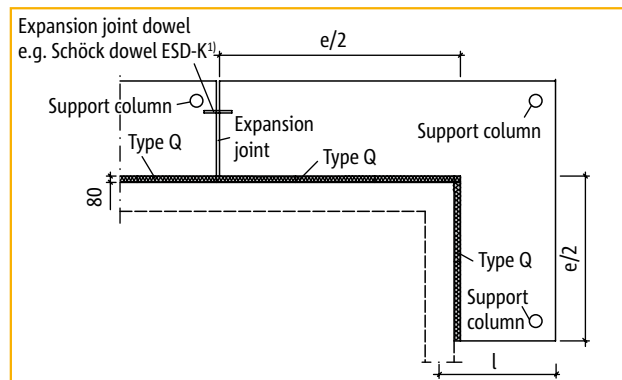

Figure 2: Layout of expansion joints for balcony slabs with a connection which goes around a corner

If standard elements are installed the maximum expansion joint spacing for balcony slabs connected with a straight edge is e . In case of balcony slabs where the connection goes around a corner, expansion joints should be installed at a maximum balcony length of $e/2$.

Maximum expansion joint spacing e [m]

Insulation material thickness [mm]	Diameter of shear force rebars [mm]		
	≤ 10	12	14
80	10.40	9.10	8.20

The distance from the centre axis of the pressure bearings to the free edge of the balcony slab or to the expansion joint has to be at least 50 mm, the axis-centre of the shear force rebars has to be at least 100 mm, the maximum 150 mm.

If HP modules are chosen to absorb horizontal forces which are perpendicular or parallel to the insulating plane (see pages 91 - 95), then care must be taken when planning the layout that no additional fixed points are created which would cause the maximum expansion joint spacing to be exceeded.

Notes

- ▶ Static proof must be presented for the adjacent slabs on both sides of the Schöck Isokorb®. Here, when calculating the reinforcement for the inner slab and balcony slabs which are adjacent to the Schöck Isokorb® element, it should be assumed that the bearing is free, as the Schöck Isokorb® type Q can only transmit shear forces.
- ▶ Minimum edge distance of 100 mm for the Schöck Isokorb® shear force bars has to be considered.
- ▶ The excentric connection results in an offset moment at the free edges of the Schöck Isokorb® type Q. It must be verified in each case that this moment is transmitted into the two adjacent slabs.
- ▶ The upper and lower reinforcement of the adjacent slabs should be located as close as possible to the thermal insulation layer on both sides of the Schöck Isokorb®, with appropriate allowances for the required concrete cover.
- ▶ The verification of the shear force in slabs has to be provided by the structural designer according to EC2 clause 6.9..
- ▶ If it is planned for horizontal forces to be transmitted in the connection area of the Schöck Isokorb® type Q, additional intermittent horizontal force modules (HP modules, see pages 91 - 95) will be required for each slab. Page 95 shows a possible layout.

¹⁾ made from stainless steel

Reinforced concrete-to-reinforced concrete

Schöck Isokorb® type Q

Method statement

Reinforced concrete-to-reinforced concrete

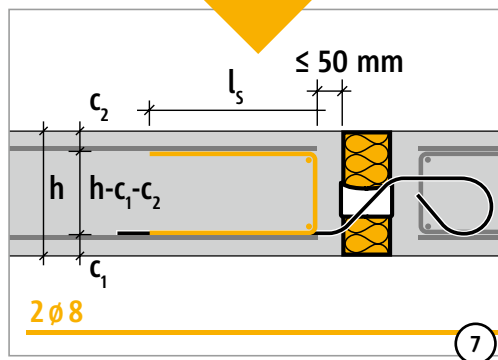
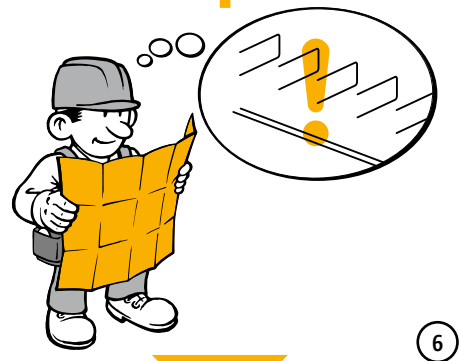
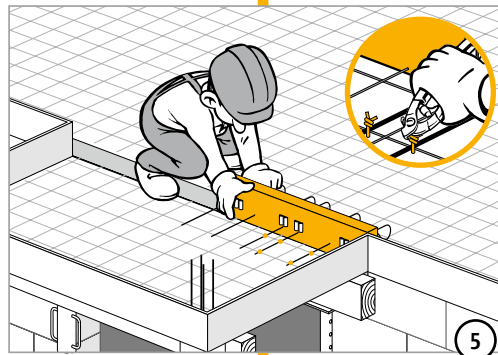
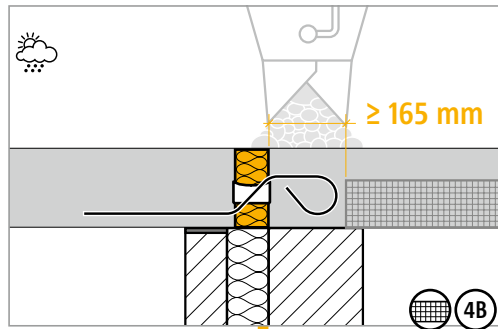
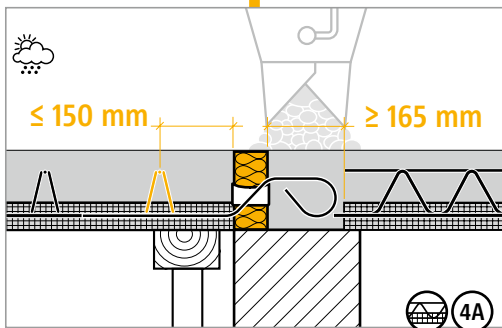
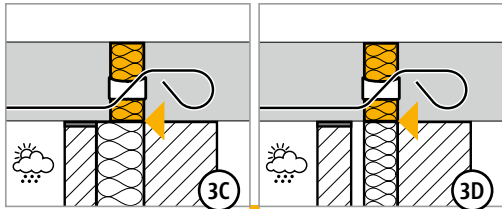
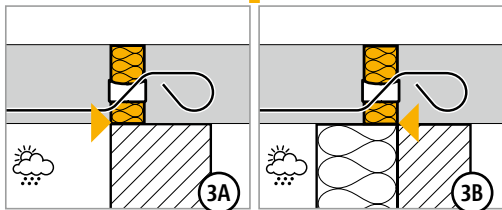
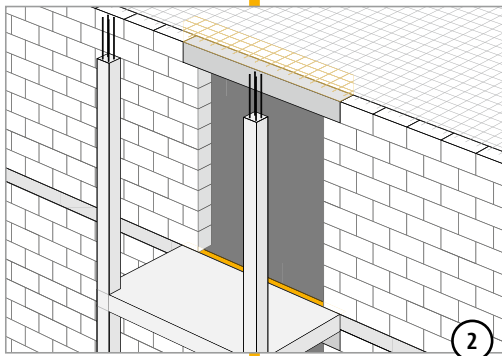
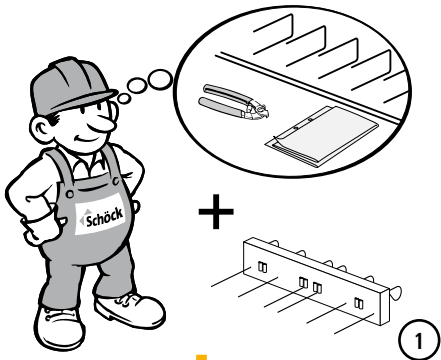

Schöck Isokorb® type Q

Method statement

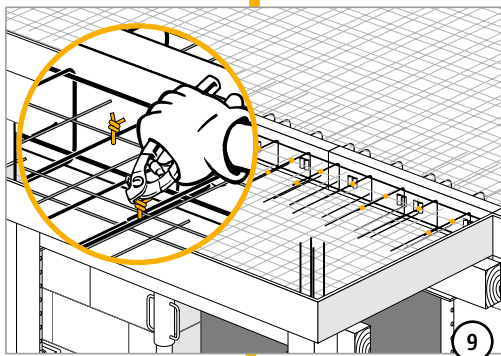
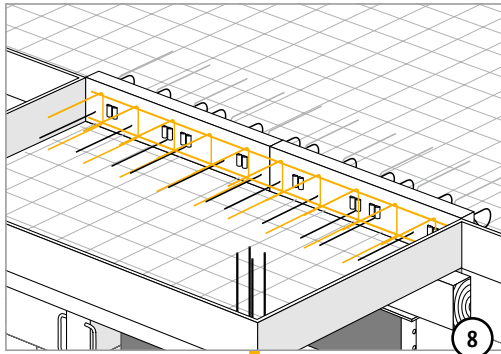

Schöck Isokorb®

Check list



- Have the member forces on the Isokorb® connection been determined at the design level?
- Was the cantilevered system length used in the process?
- Have the concrete cover and the appropriate concrete grade been taken into consideration according to the building regulations (see page 23)
- In case of precast planks will be used, is sufficient bond action between reinforced structural screed and precast planks guaranteed?
- Have the maximum permitted distances between expansion joints (= expansion joint spacing) been taken into account?
- Has the required on-site connection reinforcement been defined?
- If the balcony is supported on 2 or 3 sides, has the right type for a tension-free connection been chosen (possibly type V or type QPZ)?
- Has the relevant bearing limit of the slab been checked for shear forces according to EC2 clause 6.9.?
- In the case of a connection to an upstand or downstand beam, or a connection to a wall, is the required component geometry present?
- Have the fire safety requirements been clarified, and are they reflected in the chosen type designation (-F90)?
- In the case of F90 elements, has the increased minimum slab thickness been taken into account (type Q, type V)?
- Has horizontal loading been taken into consideration in the design (e.g. wind loads or earthquake loads)?

Q

Reinforced concrete-to-reinforced concrete

Schöck Isokorb® type V

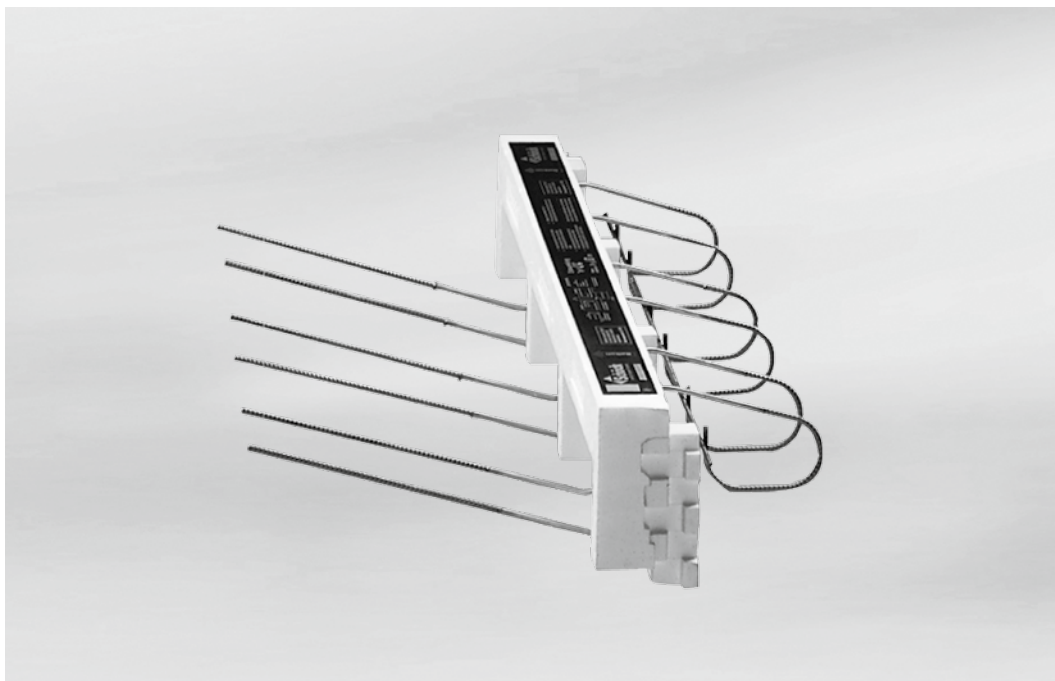

Schöck Isokorb® type V

V

Reinforced concrete-to-reinforced concrete

Contents	Page
Examples of element arrangements/Cross-sections	82
Capacity table/Plan views	83
Application examples	84
On-site reinforcement/Notes	85
Expansion joint spacing/Notes	86
Method statement	87 - 88
Check list	89
Fire resistance	16 - 17

Schöck Isokorb® type V

Examples of element arrangements/Cross-sections

V

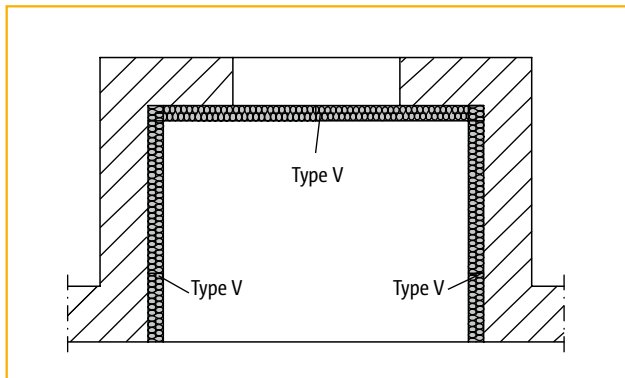

Figure 1: Balcony supported on three sides

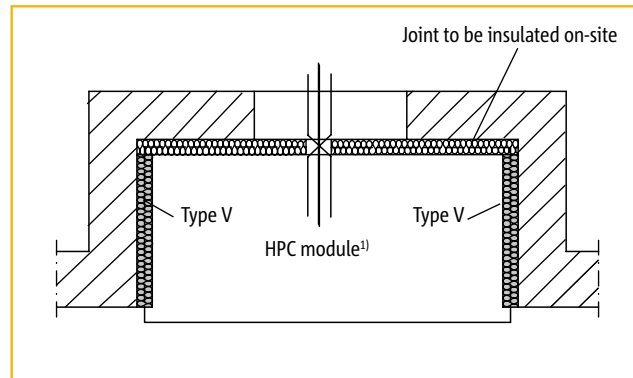

Figure 2: Balcony supported on two sides

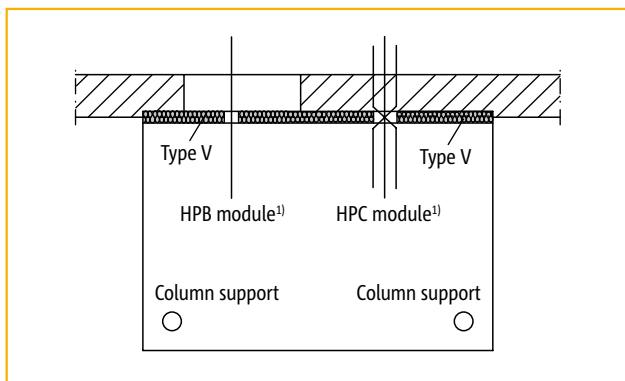

Figure 3: Balcony with column support

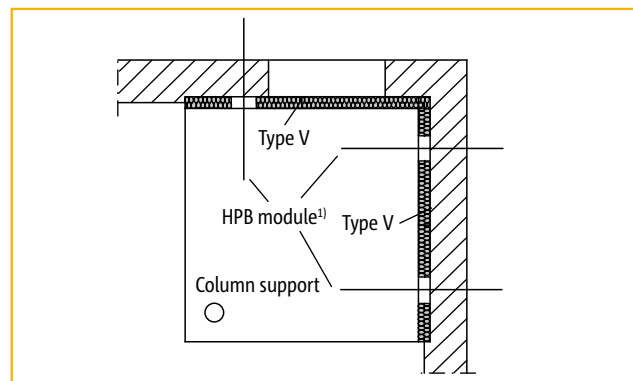

Figure 4: Balcony supported on two sides with column support

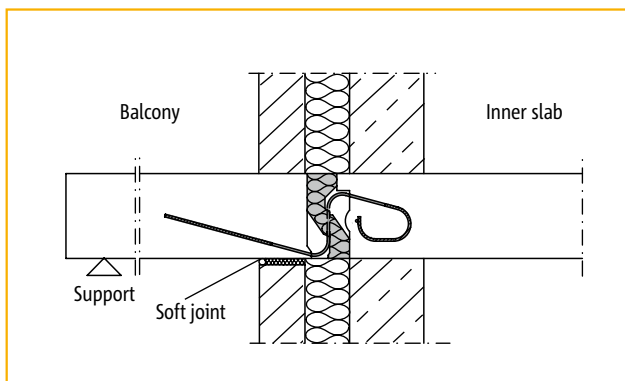

Figure 5: Cavity wall with a balcony at inner slab level

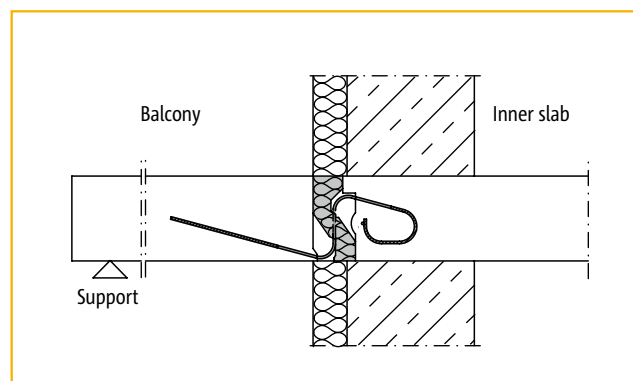

Figure 6: Brickwork with external insulation and a balcony at inner slab level

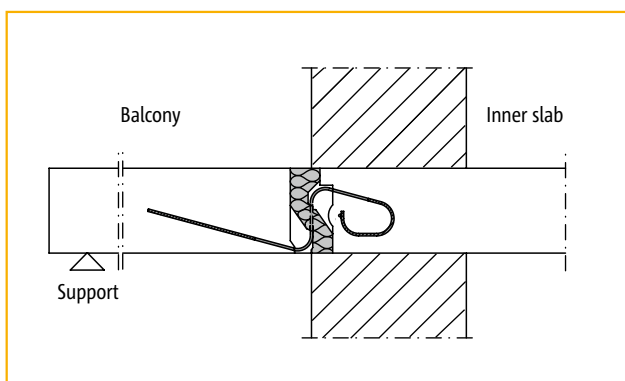

Figure 7: Single-leaf brickwork with a balcony at inner slab level

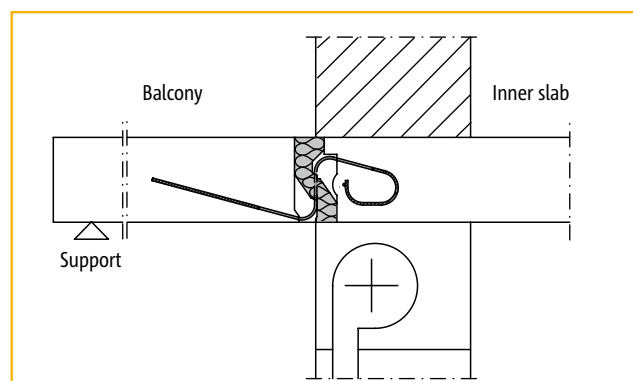

Figure 8: Single-leaf brickwork with blind box and a balcony at inner slab level

¹⁾ Only required if horizontal forces are present. Horizontal force modules HPA, HPB or HPC (see pages 91 - 95).

Schöck Isokorb® type V

Capacity table/Plan views

Type V with F 90 from H = 180 mm

Table: Rated shear forces for height of Schöck Isokorb®: H = 160 - 250 mm

Schöck Isokorb® type	Reinforcement	Isokorb® length [m]	$\geq C25/30$ V_{Rd} [kN/m]
V6/4	4 ϕ 6	1.00	+47.3
V6/6	6 ϕ 6	1.00	+70.9
V6/8	8 ϕ 6	1.00	+94,6
V6/10	10 ϕ 6	1.00	+118.2

Concrete grade for outside components at least C32/40 (see page 23).

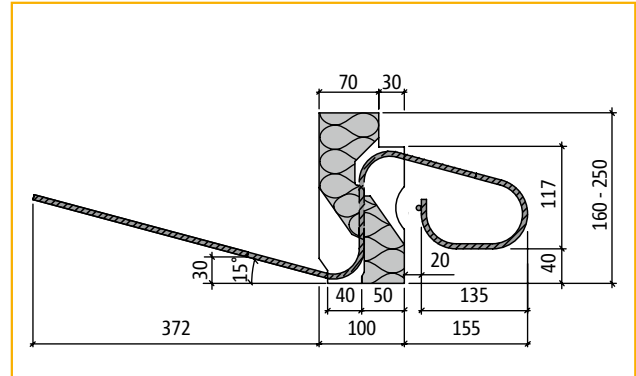

Cross-section: Schöck Isokorb® type V6/4 to V6/10

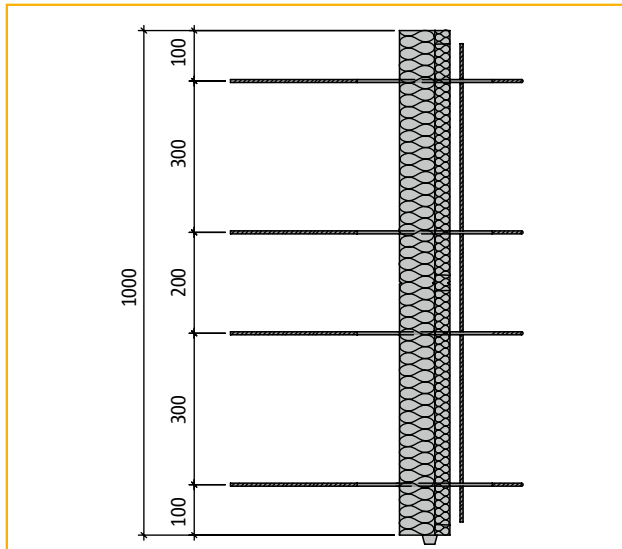

Plan view: Schöck Isokorb® type V6/4

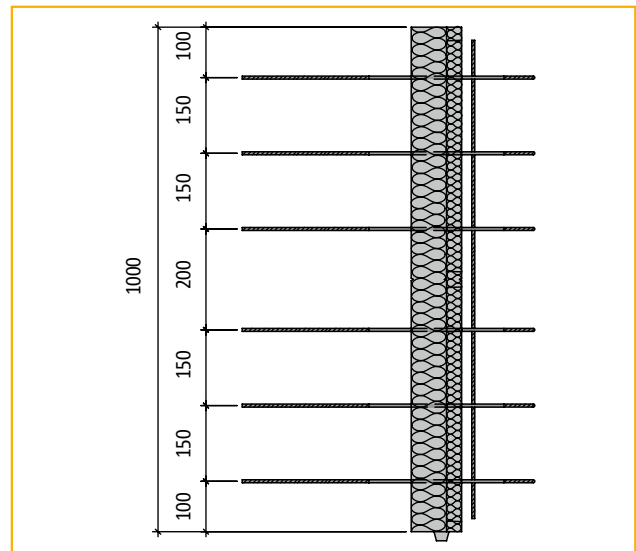

Plan view: Schöck Isokorb® type V6/6

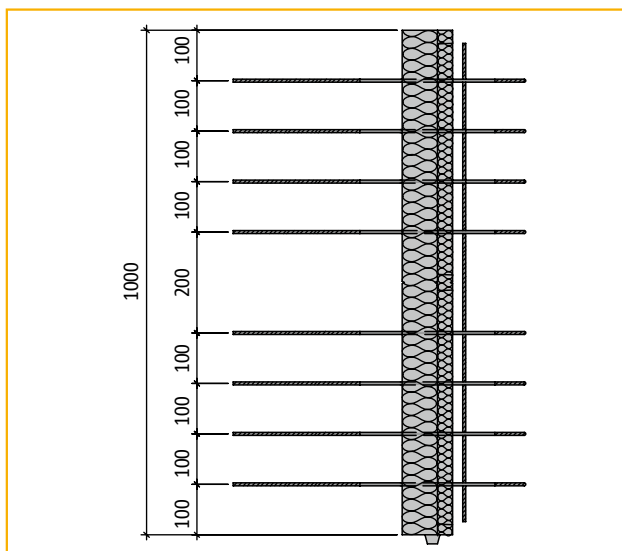

Plan view: Schöck Isokorb® type V6/8

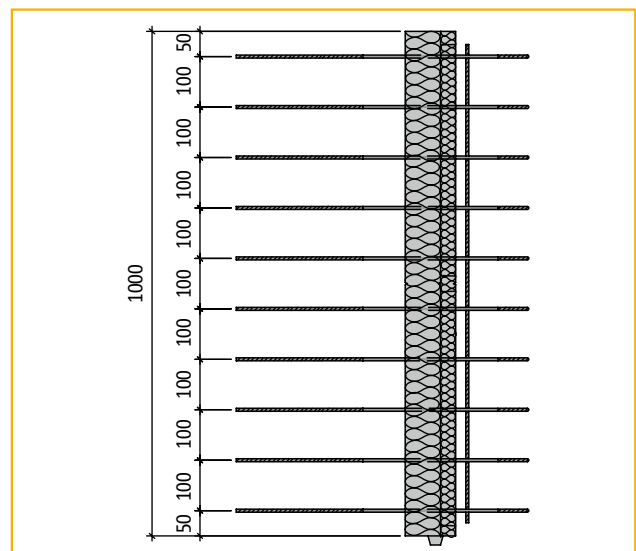

Plan view: Schöck Isokorb® type V6/10

V

Reinforced concrete-to-reinforced concrete

Schöck Isokorb® type V

Application examples

V

Reinforced concrete-to-reinforced concrete

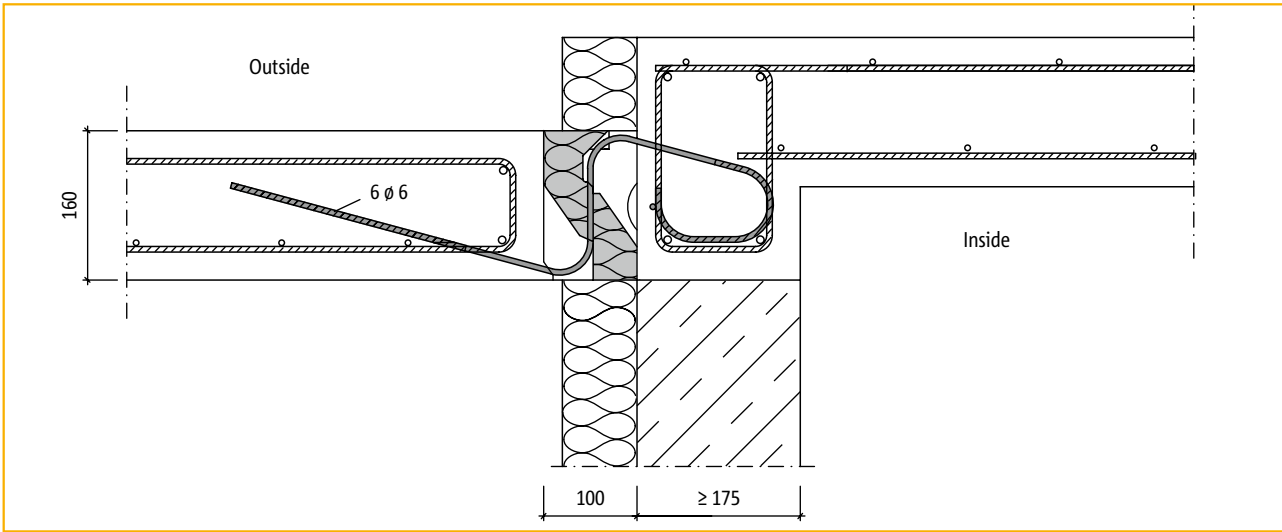

Figure 1: Cross-section of a "vertical offset" installation with Schöck Isokorb® type V6/6-H160

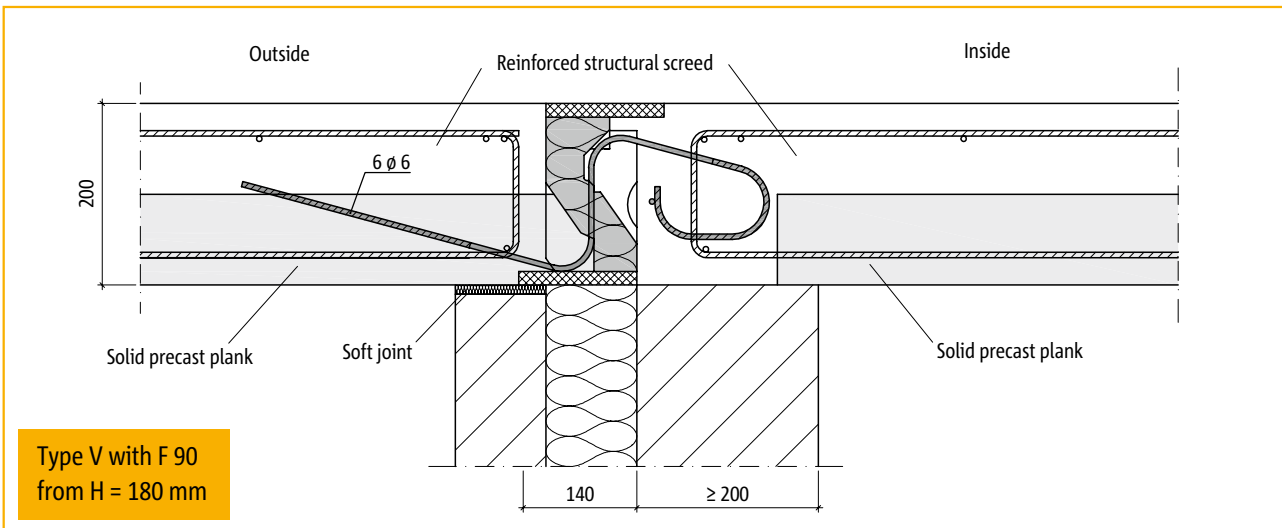

Figure 2: Cross-section of a "semi-precast balcony slab" installation with Schöck Isokorb® type V6/6-H200-F90

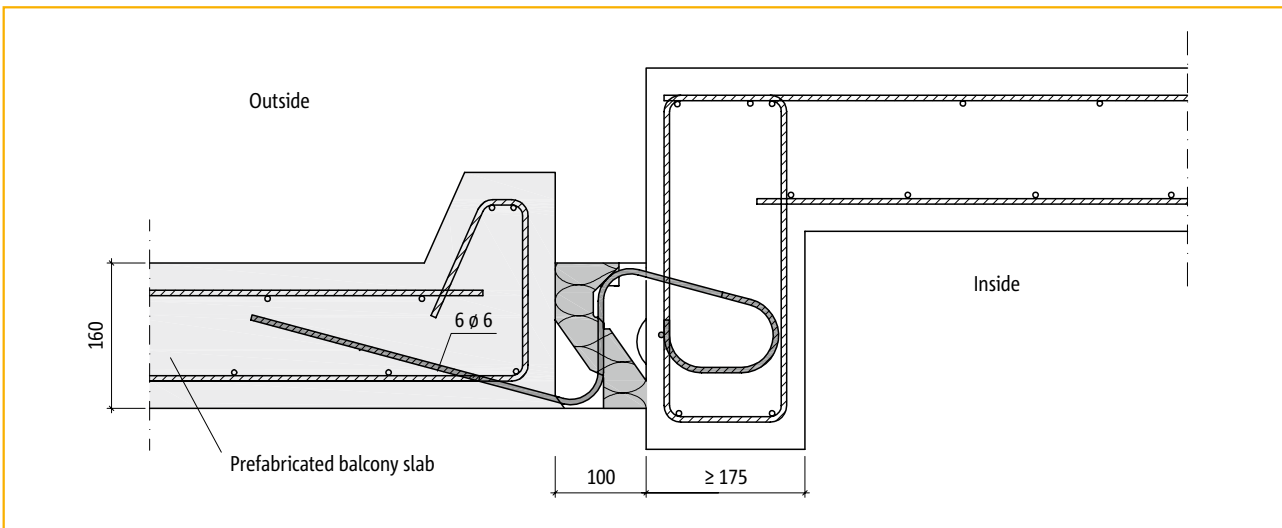
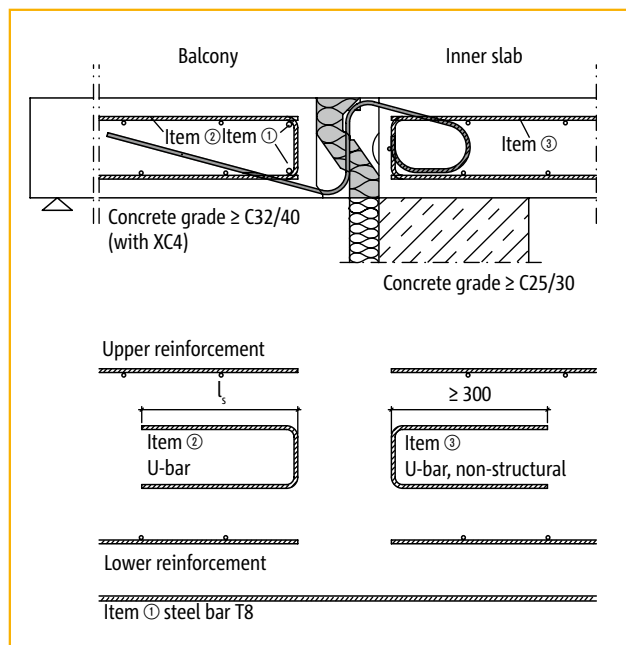

Figure 3: Cross-section of a "prefabricated balcony slab" installation with Schöck Isokorb® type V6/6-H160

Schöck Isokorb® type V

On-site reinforcement/Notes

Connection with U-bars



Schöck Isokorb® type	U-bar (item 2) req. a_s [mm ² /element]
V6/4	109
V6/6	163
V6/8	217
V6/10	272

V

Reinforced concrete-to-reinforced concrete

Notes

- ▶ Concrete grade for outside components \geq C32/40.
- ▶ The range of potential applications for Schöck Isokorb® type V elements extends only to inner slab and balcony slabs with predominantly static and evenly distributed live loads.
- ▶ Static proof must be presented for the adjacent slabs on both sides of the Schöck Isokorb®. Here, when calculating the reinforcement for the inner slab and balcony slabs which are adjacent to the Schöck Isokorb® element, it should be assumed that the barring is free, as the Schöck Isokorb® type V can only transmit shear forces.
- ▶ Minimum edge distance of 100 mm for the Schöck Isokorb® shear force bars has to be considered.
- ▶ The verification of the shear force in slabs has to be provided by the structural designer according to EC2 clause 6.9..
- ▶ The upper and lower reinforcement of the adjacent slabs should be located as close as possible to the thermal insulation layer on both sides of the Schöck Isokorb®, with appropriate allowances for the required concrete cover.
- ▶ A bearing reinforcement which has been designed to accommodate the maximum occurring shear force is to be located on the edge of the slab at the connection of the concrete slab to the Schöck Isokorb®. Both U-bars and meshes can be used for this purpose.

Schöck Isokorb® type V

Expansion joint spacing/Notes

Expansion joint spacing

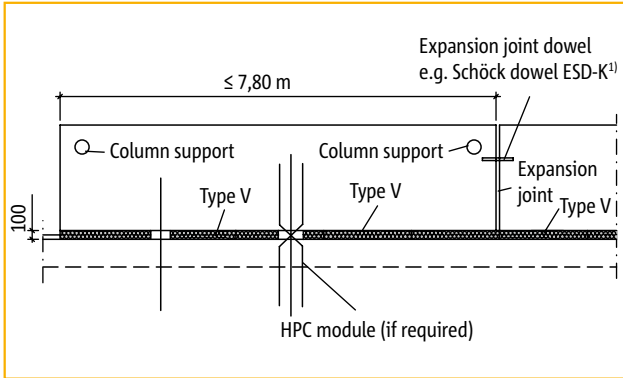

Figure 1: Plan view

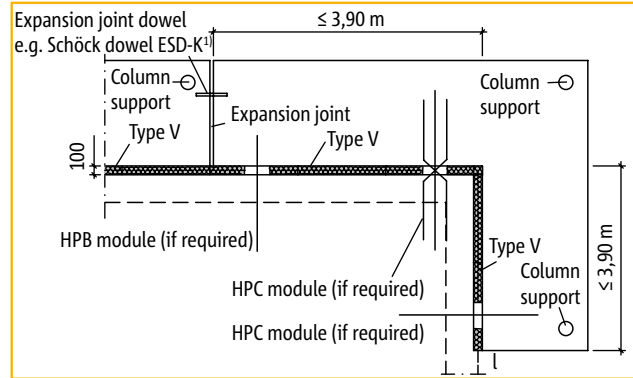

Figure 2: Plan view

The expansion joint spacing (e) is generally 7.80 m.

In the case of layouts which go around a corner the maximum element length is $e/2 = 3.90$ m.

If HP modules are chosen to absorb horizontal forces which are perpendicular or parallel to the insulating layer (see pages 91 - 95), then care must be taken when planning the layout that no additional fixed points are created which would cause the maximum expansion joint spacing to be exceeded.

Notes

- ▶ If it is planned for horizontal forces to be transmitted in the connection area of the Schöck Isokorb® type V, additional intermittent horizontal force modules (HP modules, see pages 91 - 95) will be required for each balcony slab.

¹⁾ made from stainless steel

Schöck Isokorb® type V

Method statement

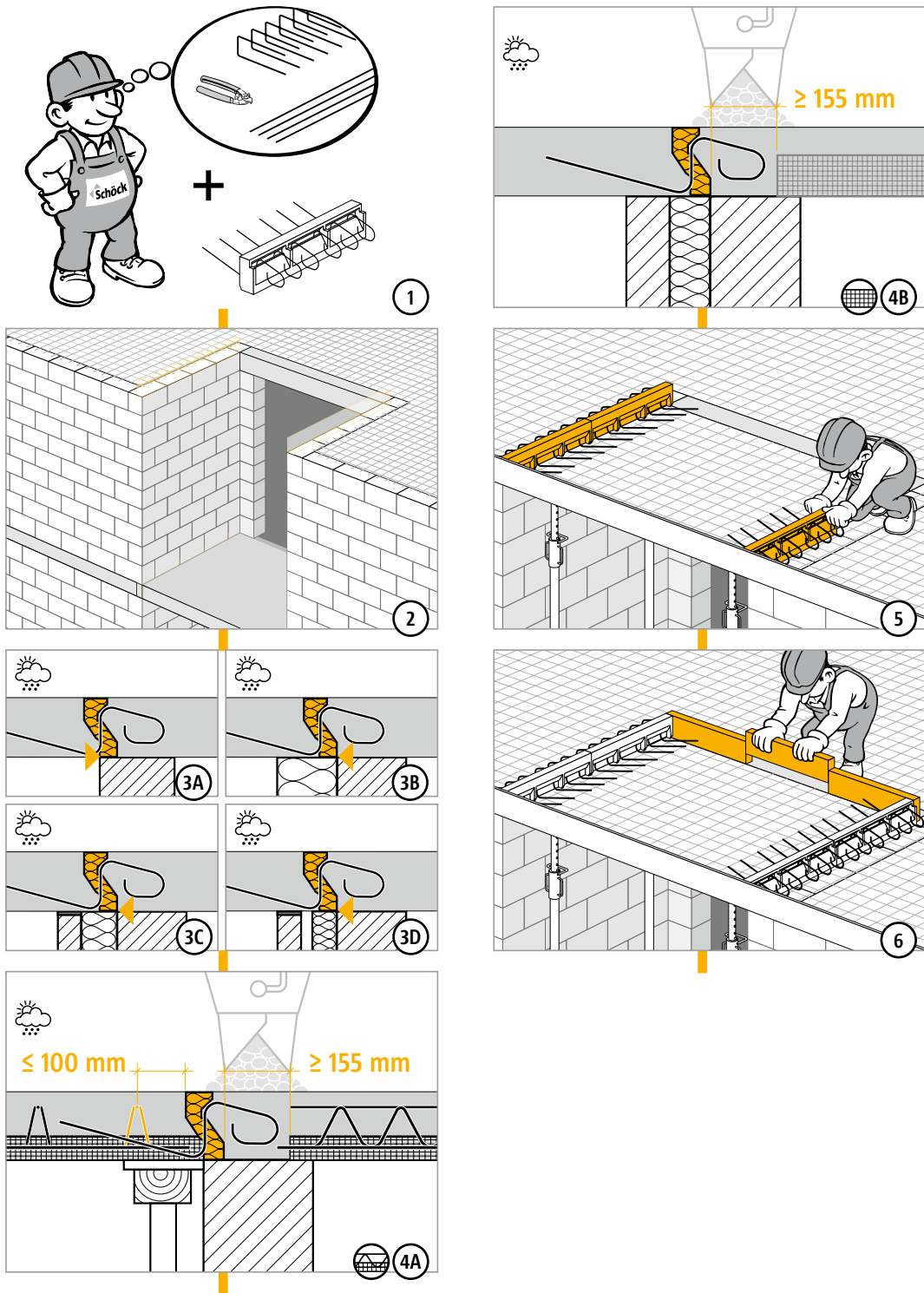

Schöck Isokorb® type V

Method statement

V

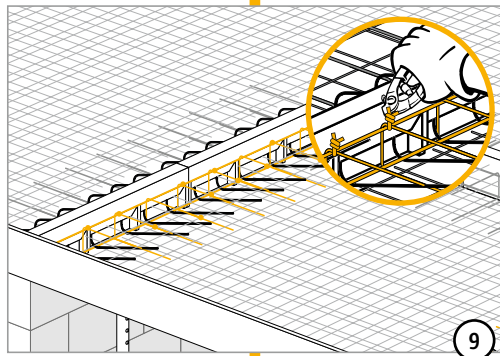
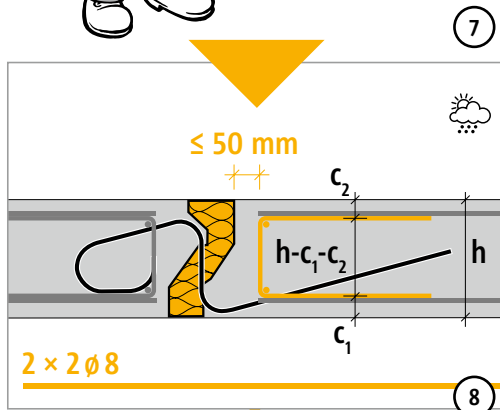

Reinforced concrete-to-reinforced concrete

Schöck Isokorb®

Check list



- Have the member forces on the Isokorb® connection been determined at the design level?
- Was the cantilevered system length used in the process?
- Have the concrete cover and the appropriate concrete grade been taken into consideration according to the building regulations (see page 23)
- In case of precast planks will be used, is sufficient bond action between reinforced structural screed and precast planks guaranteed?
- Have the maximum permitted distances between expansion joints (= expansion joint spacing) been taken into account?
- Has the required on-site connection reinforcement been defined?
- Has the relevant bearing limit of the slab been checked for shear forces according to EC2 clause 6.9.?
- In the case of a connection to an upstand or downstand beam, or a connection to a wall, is the required component geometry present?
- Have the fire safety requirements been clarified, and are they reflected in the chosen type designation (-F90)?
- In the case of F90 elements, has the increased minimum slab thickness been taken into account (type Q, type V)?

V

Reinforced concrete-to-reinforced concrete

Schöck Isokorb® type HP module

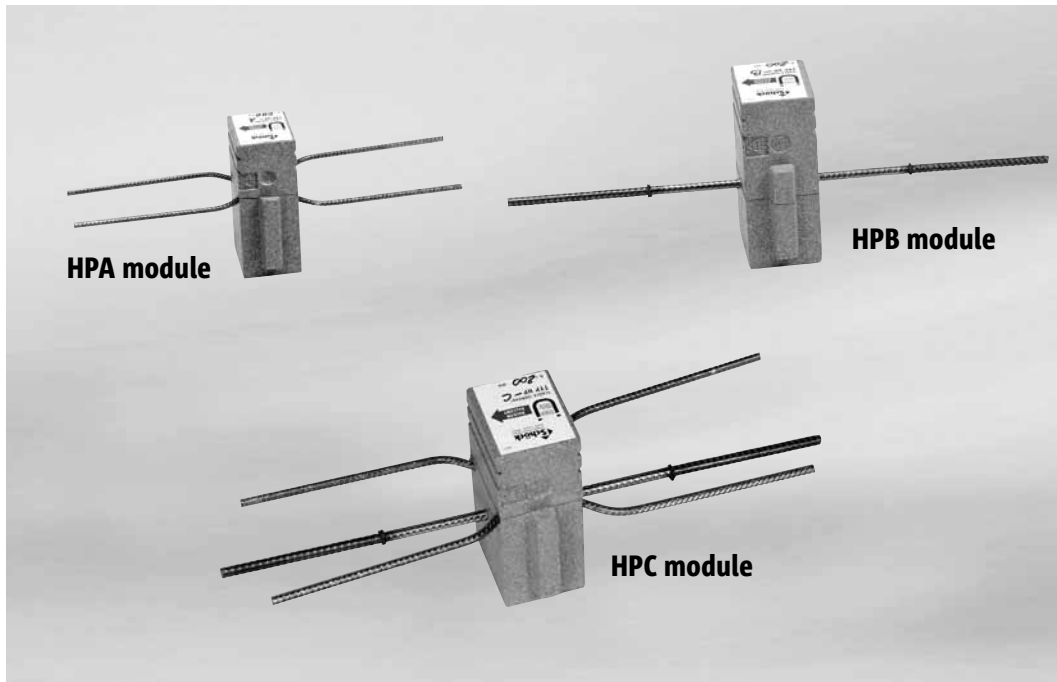

Schöck Isokorb® type HP module

HP
Module

Reinforced concrete-to-
reinforced concrete

Contents	Page
Examples of element arrangements/Cross-sections	92
Capacity tables/Cross-sections/Plan views	93
Notes/Example	94
Method statement	95
Fire resistance	16 - 17

Schöck Isokorb® type HP module

Examples of element arrangements/Cross-sections

Only required in load cases with the H-forces parallel and/or perpendicular to the insulating layer.

HP Module

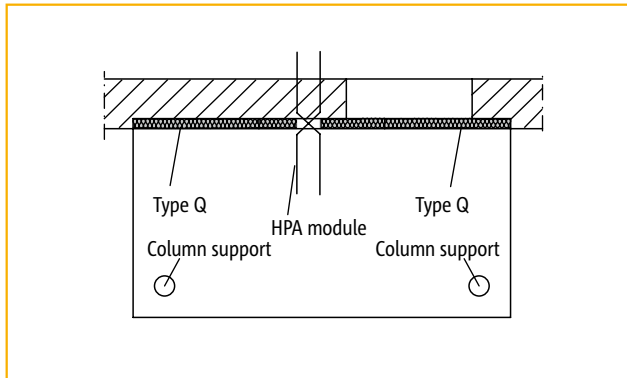

Figure 1: Balcony with column support + type Q + type HPA module

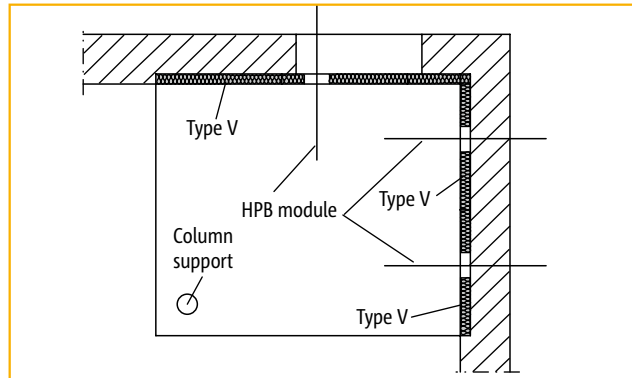

Figure 2: Balcony supported on two sides with column support + type V + type HPB module

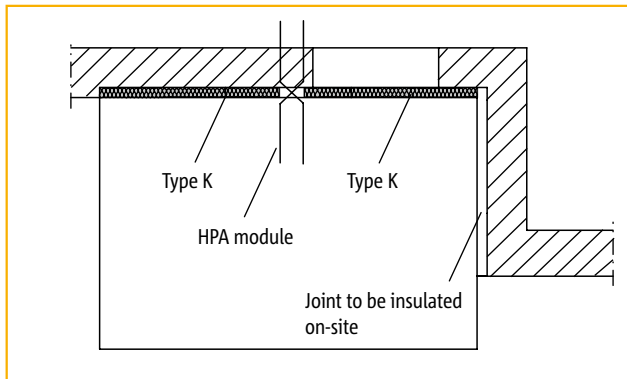

Figure 3: Free cantilever balcony + type K + type HPA module

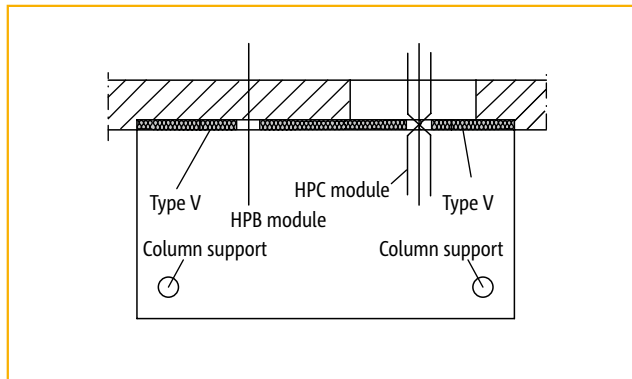

Figure 4: Balcony with column support + type V + type HPC module

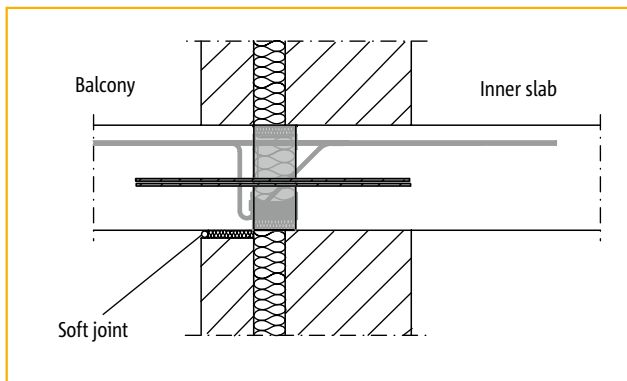

Figure 5: Cavity wall with a balcony at inner slab level + type K + type HPA module

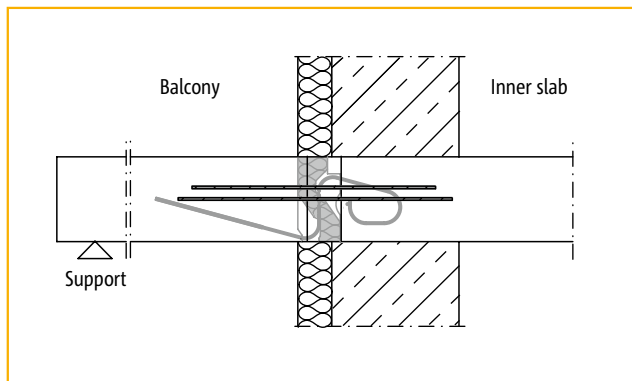

Figure 6: Brickwork with external insulation and a balcony at inner slab level + type V + type HPC module

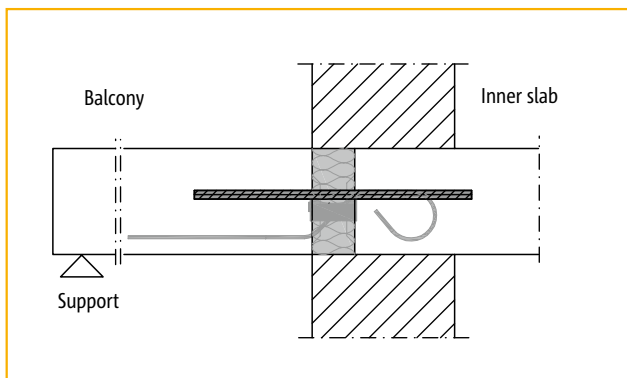

Figure 7: Single-leaf brickwork with a balcony at inner slab level + type Q + type HPA module

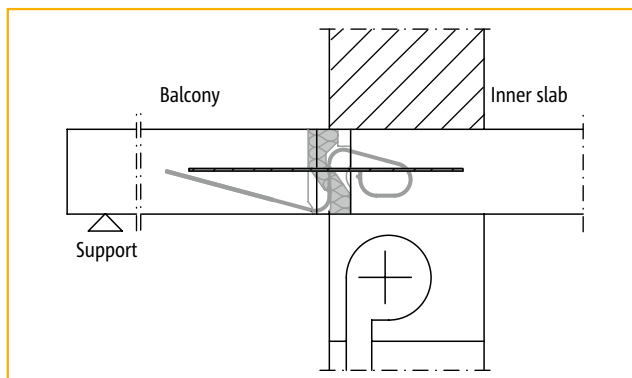

Figure 8: Single-leaf brickwork with blind box and a balcony at inner slab level + type V + type HPB module

Reinforced concrete-to-reinforced concrete

Schöck Isokorb® type HP module

Capacity tables/Cross-sections/Plan views

Schöck Isokorb® type	HPA module		HPB module		HPC module	
Design values for	$H_{Rd,II}$ [kN]	$H_{Rd,I}$ [kN]	$H_{Rd,II}$ [kN]	$H_{Rd,I}$ [kN]	$H_{Rd,II}$ [kN]	$H_{Rd,I}$ [kN]
Concrete grade C25/30	±8.6	0	0	±20.9	±8.6	±20.9
Shear force bar	2 x 1 ϕ 8		-		2 x 1 ϕ 8	
H-anchor	-		1 ϕ 10		1 ϕ 10	
Element length [mm]	100		100		100	
Height of Isokorb® [mm]	160 - 250		160 - 250		160 - 250	

- ▶ $H_{Rd,II}$: Design values for Member forces per element, taken parallel to the insulating layer.
- ▶ $H_{Rd,I}$: Design values for Member forces per element, taken perpendicular to the insulating layer.
- ▶ Concrete grade for outside components \geq C32/40.

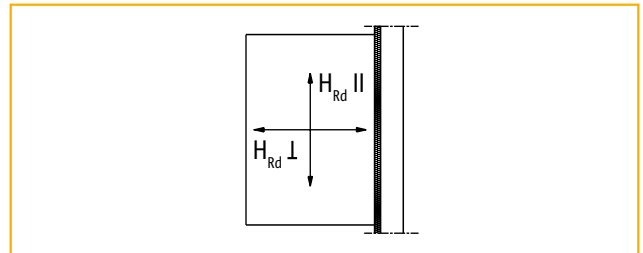

$H_{Rd,II}$ -forces II and $H_{Rd,I}$ -forces I to the insulating layer

Schöck Isokorb® type HPA module for member forces acting parallel to the insulating layer

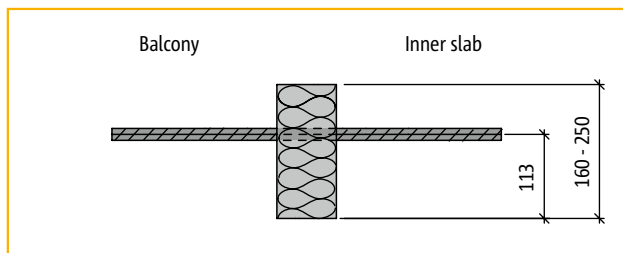

Cross-section: type HPA module

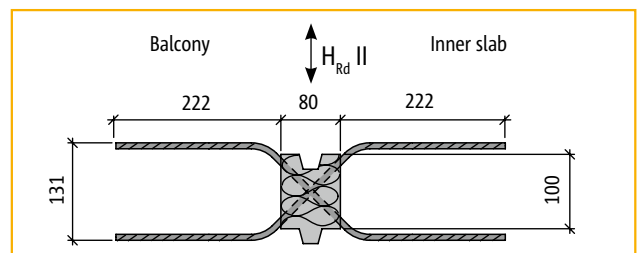

Plan view: type HPA module

Schöck Isokorb® type HPB module for member forces acting perpendicular to the insulating layer

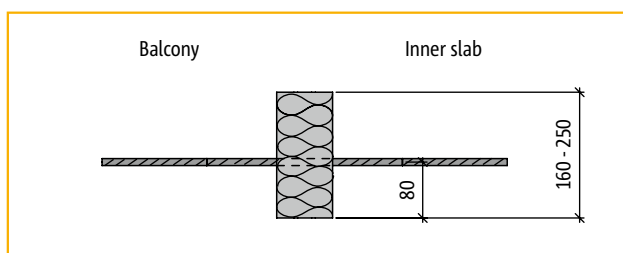

Cross-section: type HPB module

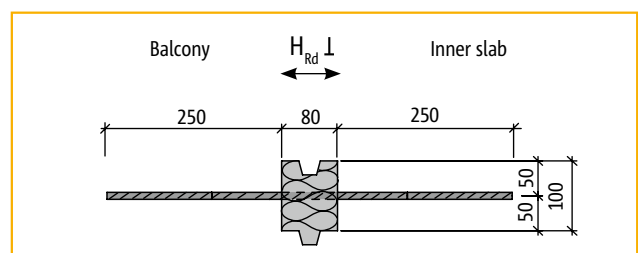

Plan view: type HPB module

Schöck Isokorb® type HPC module for member forces acting parallel or perpendicular to the insulating layer

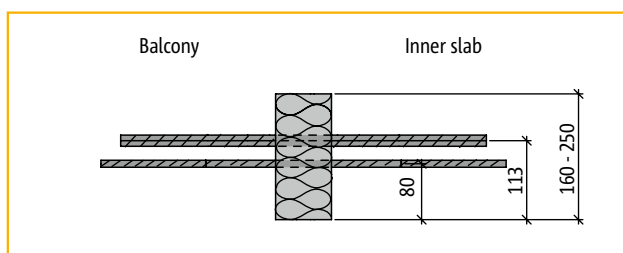

Cross-section: type HPC module

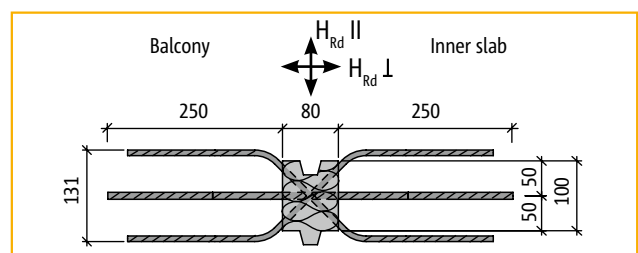

Plan view: type HPC module

HP
Module

Reinforced concrete-to-
reinforced concrete

Schöck Isokorb® type HP module

Notes/Example

Notes

- ▶ The type HP module is to be incorporated in your plans only if horizontal forces are present in the design, and then only in conjunction with a Schöck Isokorb® basic type for straight line or pointwise connections (e.g. type K, type Q, type QP, type V).
- ▶ When choosing the correct type (type HPA module, HPB module or HPC module) and its arrangement, care must be taken to ensure that no unnecessary fixed points are created and that the maximum expansion joint spacings (for e.g. type K, type Q, type V) are satisfied in the process.
- ▶ The required quantity of HP modules is determined by the engineer in charge of the planning of the structure in accordance with the static requirements.
- ▶ When calculating the straight line connection, it should be noted that the use of a module of type HP can lead to a reduction of the resistance member forces of the straight line connection (e.g. the use of a type V with $L = 1.0$ m and a type HP module with $L = 0.1$ m (alternating regularly) means a reduction of v_{rd} of the straight line connection with type V by around 9 %).

Example

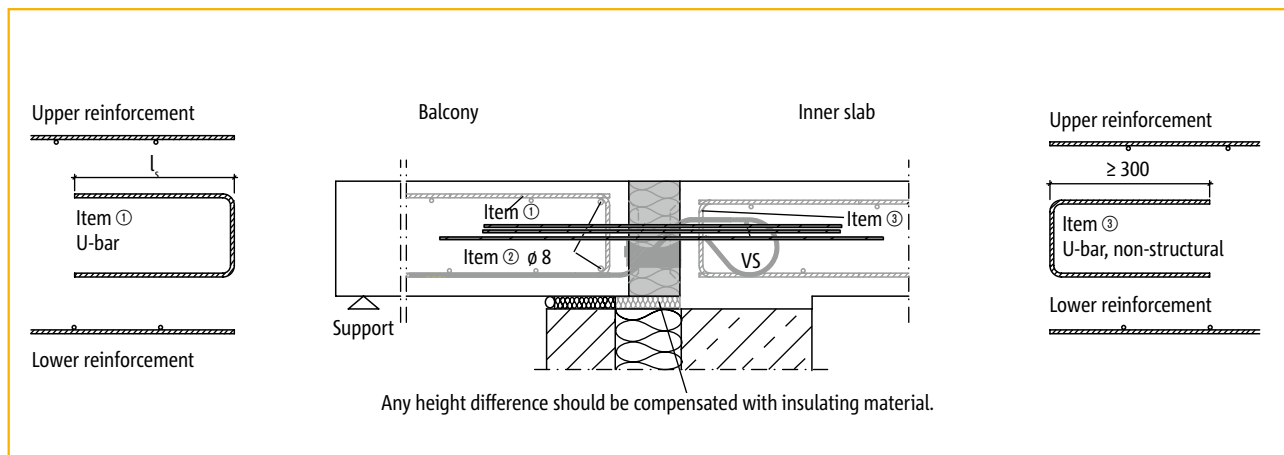

Schöck Isokorb® type HP module

Method statement

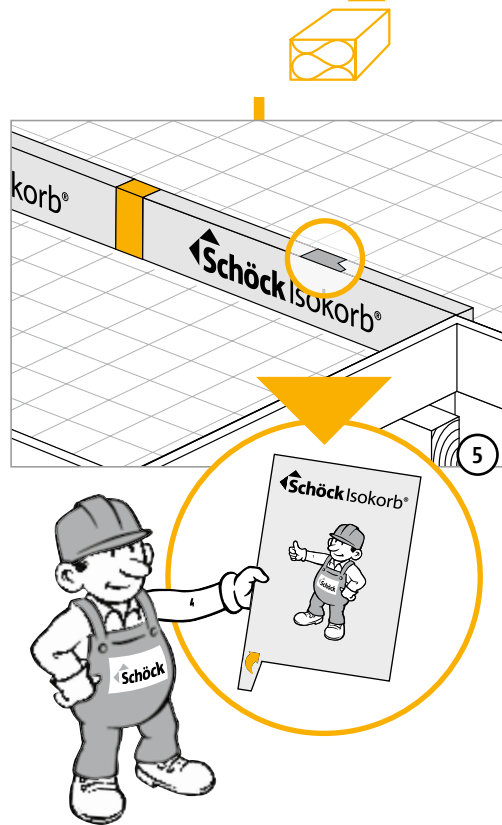
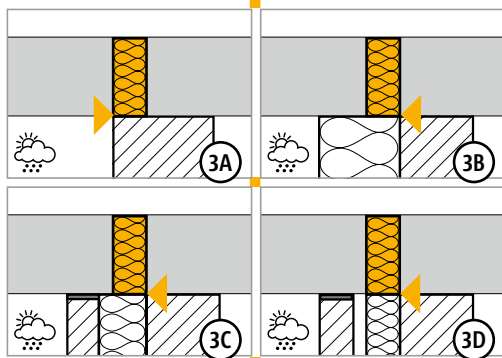
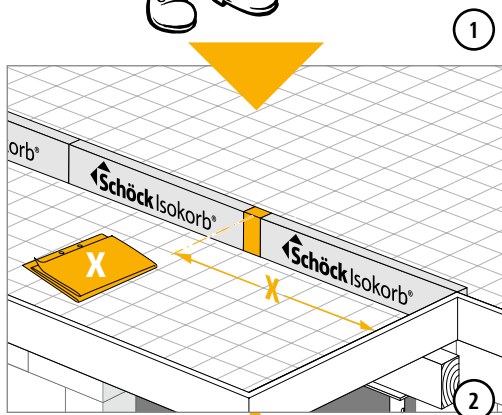
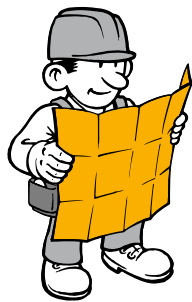
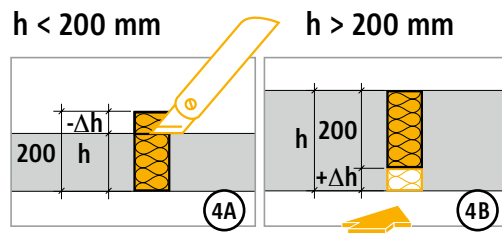
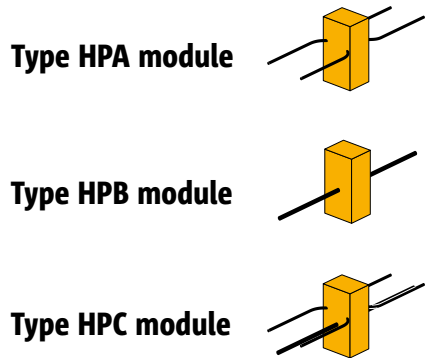

HP
Module

Reinforced concrete-to-
reinforced concrete

Schöck Isokorb® type D

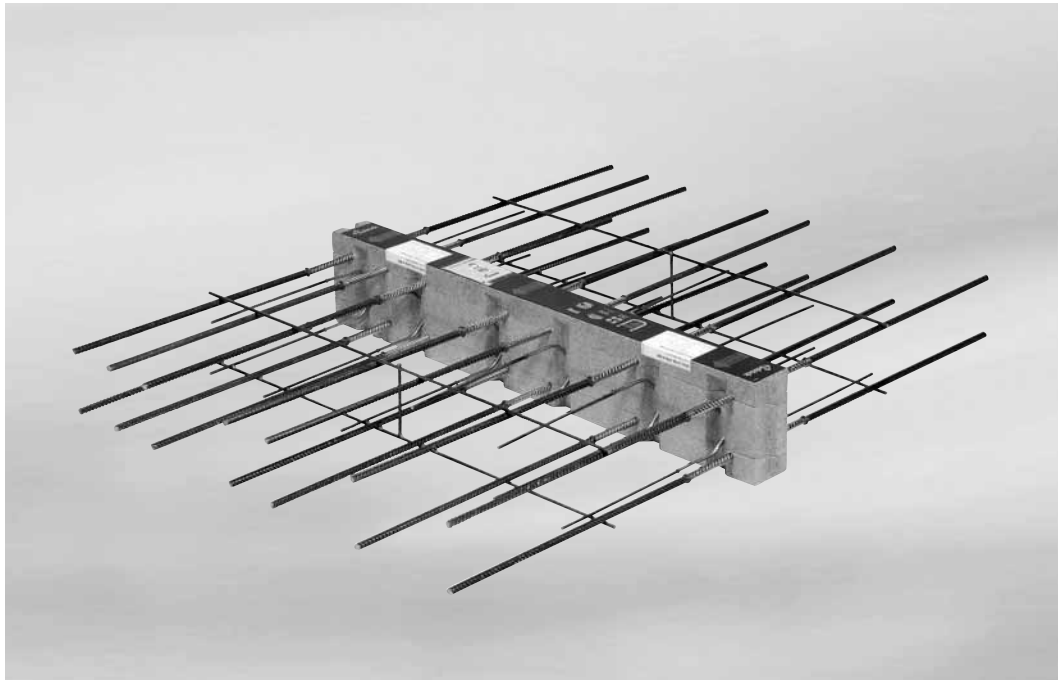

Schöck Isokorb® type D

D

Reinforced concrete-to-reinforced concrete

Contents	Page
Capacity tables/Examples of element arrangements	98 - 99
Plan views	100
Lap splice design/Notes/Expansion joint spacing	101
Method statement	102 - 103
Check list	104
Fire resistance	16 - 17

Schöck Isokorb® type D

Capacity tables for C25/30 / Examples of element arrangements

D

Reinforced concrete-to-reinforced concrete

Schöck Isokorb® type			D30-...-VV6	D30-...-VV8	D30-...-VV10	D50-...-VV6	D50-...-VV8	D50-...-VV10
Design values for	Concrete cover CV [mm]		Concrete grade ≥ C25/30					
	CV30	CV35	CV50 ¹⁾	Moment capacity m_{Rd} [kNm/m]				
Height of Isokorb® H [mm]		160	±18.3	–	–	±26.5	–	–
	160		±19.4	–	–	±28.1	–	–
		170	±20.5	±18.6	–	±29.7	±27.8	–
	170		±21.6	±19.6	–	±31.3	±29.3	–
		180	±22.7	±20.6	±18.5	±32.9	±30.8	±28.6
	180		±23.8	±21.6	±19.4	±34.5	±32.3	±30.0
		190	±24.9	±22.6	±20.3	±36.1	±33.8	±31.4
	190		±26.0	±23.6	±21.2	±37.6	±35.3	±32.8
		200	±27.1	±24.6	±22.1	±39.2	±36.7	±34.2
	200		±28.2	±25.6	±23.0	±40.8	±38.2	±35.6
		210	±29.3	±26.6	±23.9	±42.4	±39.7	±37.0
	210		±30.4	±27.6	±24.8	±44.0	±41.2	±38.4
		220	±31.5	±28.6	±25.6	±45.6	±42.7	±39.7
	220		±32.6	±29.6	±26.5	±47.2	±44.2	±41.1
		230	±33.7	±30.6	±27.4	±48.8	±45.7	±42.5
	230		±34.8	±31.6	±28.3	±50.4	±47.2	±43.9
		240	±35.9	±32.6	±29.2	±52.0	±48.7	±45.3
240		±37.0	±33.6	±30.1	±53.6	±50.2	±46.7	
	250	±38.1	±34.6	±31.0	±55.2	±51.7	±48.1	
250		±39.2	±35.6	±31.9	±56.8	±53.2	±49.5	
Shear force variants			Shear force capacity v_{Rd} [kN/m]					
	VV6-VV10 ²⁾		±52.2	±92.7	±134.4	±52.2	±92.7	±134.4

Schöck Isokorb® type			D30-...-VV6	D30-...-VV8	D30-...-VV10	D50-...-VV6	D50-...-VV8	D50-...-VV10
Product description	Isokorb® length [m]	1.00			1.00			
	Tension/Compression bars	2 x 5 ϕ 12			2 x 7 ϕ 12			
	Shear force bars	2 x 6 ϕ 6	2 x 6 ϕ 8	2 x 6 ϕ 10	2 x 6 ϕ 6	2 x 6 ϕ 8	2 x 6 ϕ 10	

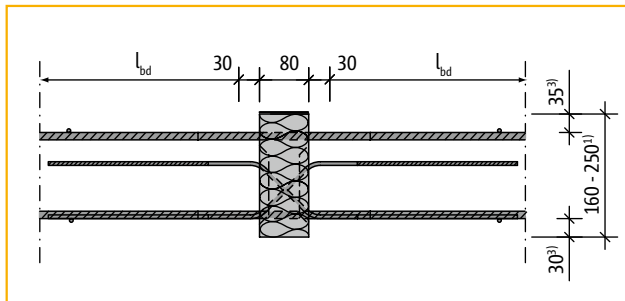

Cross-section: Schöck Isokorb® type D-CV35

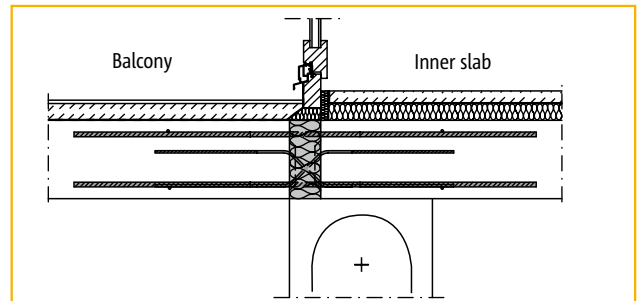

Figure 2: Cross-section through balcony and inner slab

Designations used in planning documents: e.g. D50-CV35-VV8-H180-F90

Type+load range-Concrete cover-Shear force variant-Height of Isokorb-Fire protection class

¹⁾ Min. slab height, $h \geq 200$ mm, due to this the type D CV50 (2nd layer) has 40 mm smaller internal lever arm and therefore reduced m_{Rd}

²⁾ The verification of the shear force in slabs has to be provided by the structural designer according to EC2 clause 6.9..

³⁾ 50 mm for CV50 (= 2nd layer), 30 mm for CV30

Schöck Isokorb® type D

Capacity tables for C25/30 / Examples of element arrangements

Schöck Isokorb® type			D70-...-VV6	D70-...-VV8	D70-...-VV10	D90-...-VV6	D90-...-VV8	D90-...-VV10	
Design values for	Concrete cover CV [mm]		Concrete grade \geq C25/30						
	CV30	CV35	CV50 ¹⁾	Moment capacity m_{rd} [kNm/m]					
Height of Isokorb® H [mm]		160		±38.8	–	–	±46.9	–	–
	160		200	±41.1	–	–	±49.8	–	–
		170		±43.4	±41.5	–	±52.6	±50.7	–
	170		210	±45.8	±43.8	–	±55.4	±53.4	–
		180		±48.1	±46.0	±43.9	±58.3	±56.2	±54.0
	180		220	±50.4	±48.2	±46.0	±61.1	±58.9	±56.6
		190		±52.8	±50.5	±48.1	±63.9	±61.6	±59.3
	190		230	±55.1	±52.7	±50.3	±66.7	±64.3	±61.9
		200		±57.4	±54.9	±52.4	±69.6	±67.1	±64.5
	200		240	±59.8	±57.2	±54.5	±72.4	±69.8	±67.1
		210		±62.1	±59.4	±56.6	±75.2	±72.5	±69.8
	210		250	±64.4	±61.6	±58.8	±78.0	±75.2	±72.4
		220		±66.8	±63.9	±60.9	±80.9	±78.0	±75.0
	220			±69.1	±66.1	±63.0	±83.7	±80.7	±77.6
		230		±71.4	±68.3	±65.2	±86.5	±83.4	±80.2
	230			±73.8	±70.6	±67.3	±89.4	±86.2	±82.9
		240		±76.1	±72.8	±69.4	±92.2	±88.9	±85.5
240			±78.4	±75.0	±71.5	±95.0	±91.6	±88.1	
	250		±80.8	±77.3	±73.7	±97.8	±94.3	±90.7	
250			±83.1	±79.5	±75.8	±100.7	±97.1	±93.4	
Shear force variants			Shear force capacity v_{rd} [kN/m]						
	VV6-VV10 ²⁾		±52.2	±92.7	±134.4	±52.2	±92.7	±134.4	

Schöck Isokorb® type		D70-...-VV6	D70-...-VV8	D70-...-VV10	D90-...-VV6	D90-...-VV8	D90-...-VV10
Product description	Isokorb® length [m]	1.00			1.00		
	Tension/Compression bars	2 x 10 ϕ 12			2 x 12 ϕ 12		
	Shear force bars	2 x 6 ϕ 6	2 x 6 ϕ 8	2 x 6 ϕ 10	2 x 6 ϕ 6	2 x 6 ϕ 8	2 x 6 ϕ 10

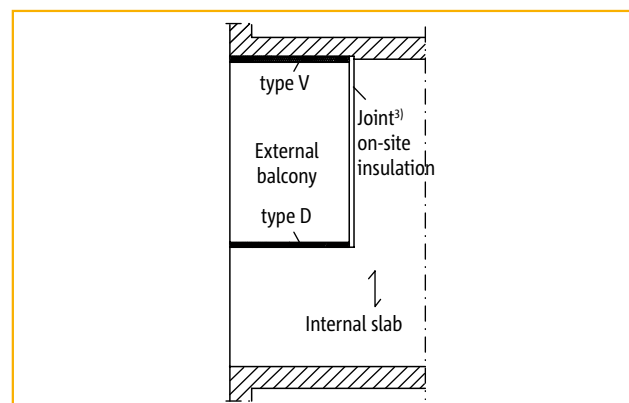

Figure 1: One-way spanning internal slab

Note

Load bearing thermal break elements (Isokorb units), generally used as balcony connectors, can only resist uni-axial bending moments. Concrete-to-concrete thermal break connectors cannot transmit any torsional moments. For this reason the use of a D type in a RC slab supported by 4 columns is not appropriate.

¹⁾ Min. slab height, $h \geq 200$ mm, due to this the type D CV50 (2nd layer) has 40 mm smaller internal lever arm and therefore reduced m_{rd}

²⁾ The verification of the shear force in slabs has to be provided by the structural designer according to EC2 clause 6.9..

³⁾ A non-structural shear force connection should be provided if required, e.g. type Q+Q.

Schöck Isokorb® type D

Plan views

D

Reinforced concrete-to-reinforced concrete

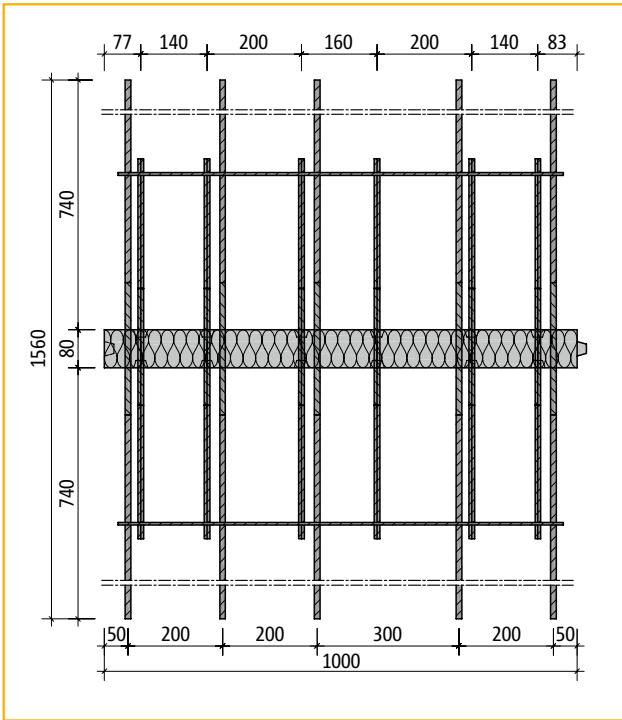

Plan view: Schöck Isokorb® type D30-CV35

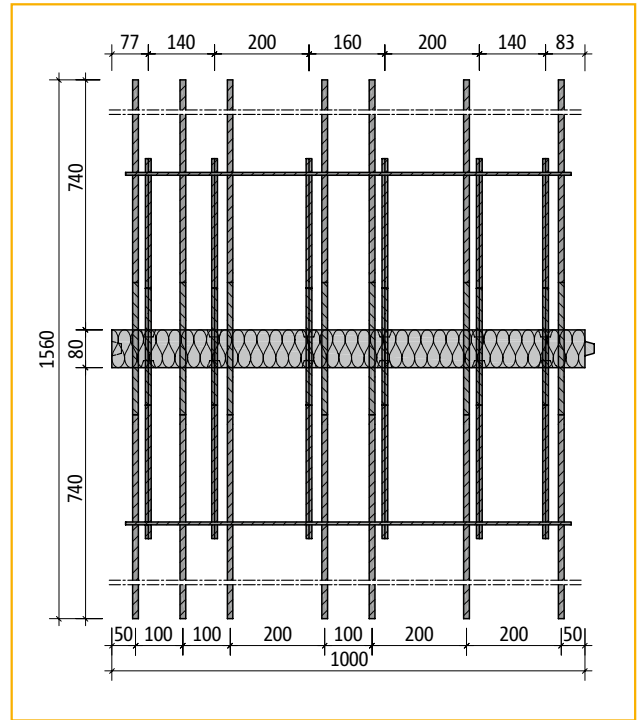

Plan view: Schöck Isokorb® type D50-CV35

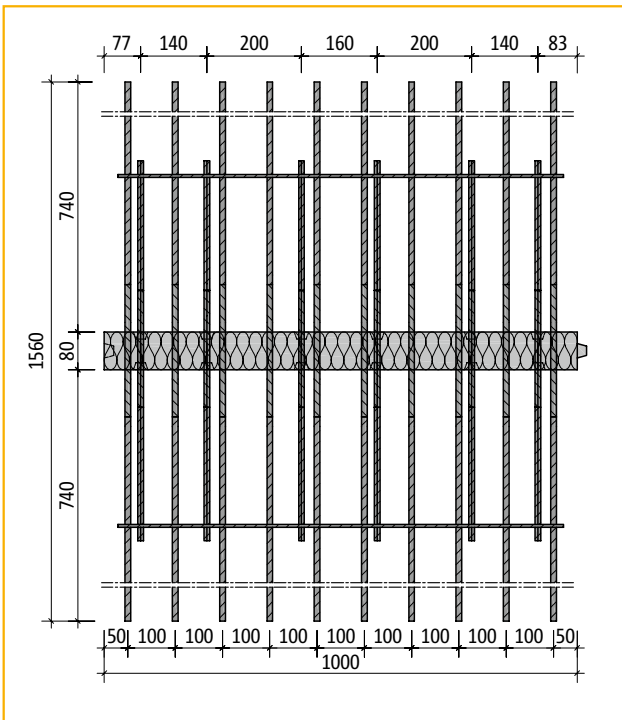

Plan view: Schöck Isokorb® type D70-CV35

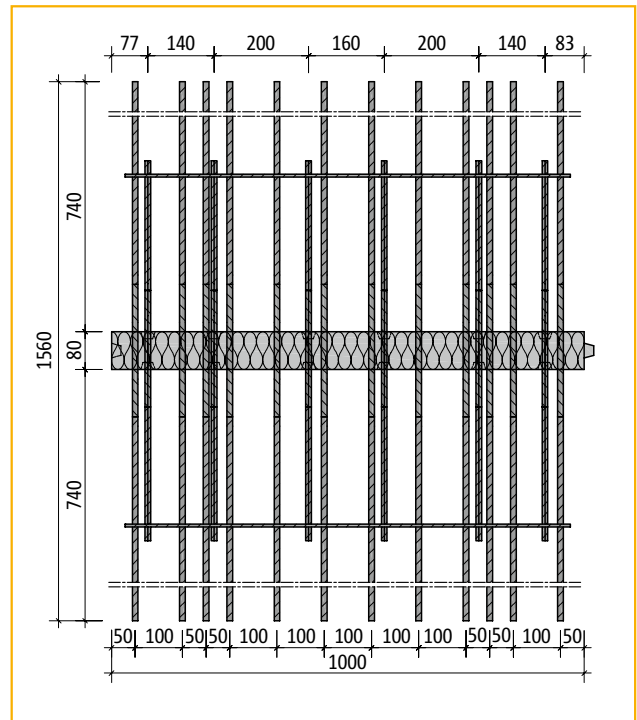

Plan view: Schöck Isokorb® type D90-CV35

Schöck Isokorb® type D

Lap splice design/Notes/Expansion joint spacing

Additional lap splice reinforcement

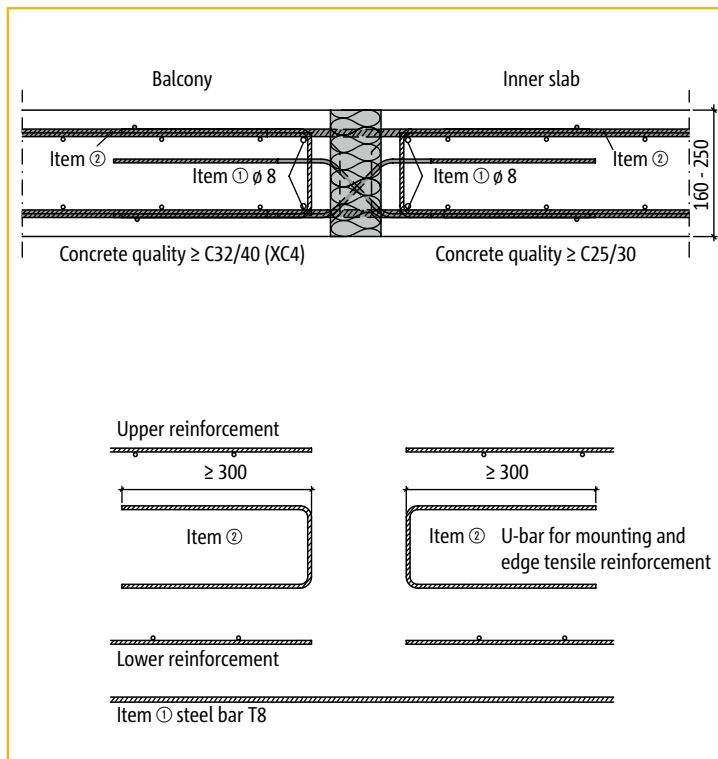

Schöck Isokorb® type	Reinforcement, item ②
D30-CV35-VV6	T8@150 mm c/c
D30-CV35-VV8	T8@150 mm c/c
D30-CV35-VV10	T8@150 mm c/c
D50-CV35-VV6	T8@150 mm c/c
D50-CV35-VV8	T8@150 mm c/c
D50-CV35-VV10	T8@150 mm c/c
D70-CV35-VV6	T8@150 mm c/c
D70-CV35-VV8	T8@150 mm c/c
D70-CV35-VV10	T8@150 mm c/c
D90-CV35-VV6	T8@150 mm c/c
D90-CV35-VV8	T8@150 mm c/c
D90-CV35-VV10	T8@150 mm c/c

Reinforced concrete-to-reinforced concrete

Notes

- ▶ Concrete strength class for outside components at least C32/40 (see page 23).
- ▶ In the case of a combination of different concrete grades (e.g. balcony C32/40, inner slab C25/30), the weaker concrete is critical in terms of the Isokorb® calculations.
- ▶ Static proof must be presented for the adjacent slabs on both sides of the Schöck Isokorb®.
- ▶ The upper and lower lap splice reinforcement should be located as close as possible to the thermal insulation layer on both sides of the Schöck Isokorb®, with appropriate allowances for the required concrete cover.
- ▶ All free unsupported edges are to be bound with a non-structural reinforcement (U-bars).
- ▶ The verification of the shear force in slabs has to be provided by the structural designer according to EC2 clause 6.9..

Expansion joint spacing

Maximum expansion joint spacing e [m]

Insulation material thickness [mm]	Schöck Isokorb® type	
	D30, D50, D70, D90 at VV6 and VV8	D30, D50, D70, D90 at VV10
80	11.30 m	10.58 m

Schöck Isokorb® type D

Method statement

D

Reinforced concrete-to-reinforced concrete

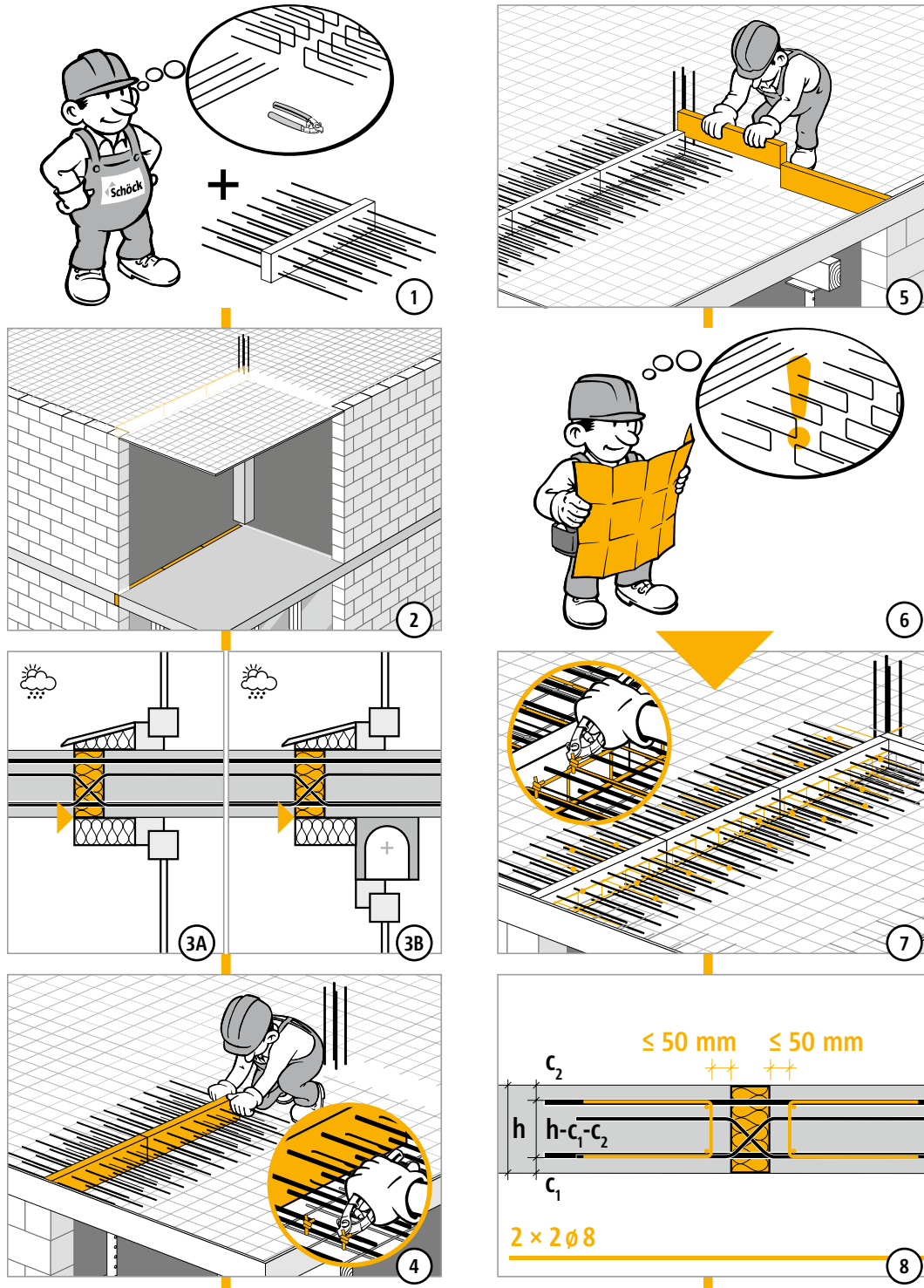

Schöck Isokorb® type D

Method statement

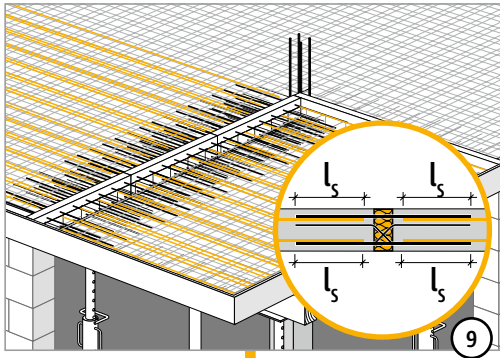

D

Reinforced concrete-to-reinforced concrete

Schöck Isokorb® type D

Check list



D

- Have the member forces on the Isokorb® connection been determined at the design level?
- Was the cantilevered system length used in the process?
- Have the concrete cover and the appropriate concrete grade been taken into consideration according to the building regulations (see page 23)
- In case of precast planks will be used, is sufficient bond action between reinforced structural screed and precast planks guaranteed?
- Have the maximum permitted distances between expansion joints (= expansion joint spacing) been taken into account?
- Has the required lap splice reinforcement been defined?
- Have the fire safety requirements been clarified, and are they reflected in the chosen type designation (-F90)?
- In the case of F90 elements, has the increased minimum slab thickness been taken into account (type Q, type V)?
- Has the relevant bearing limit of the slab been checked for shear forces according to EC2 clause 6.9.

Reinforced concrete-to-reinforced concrete

Schöck Isokorb® type 0

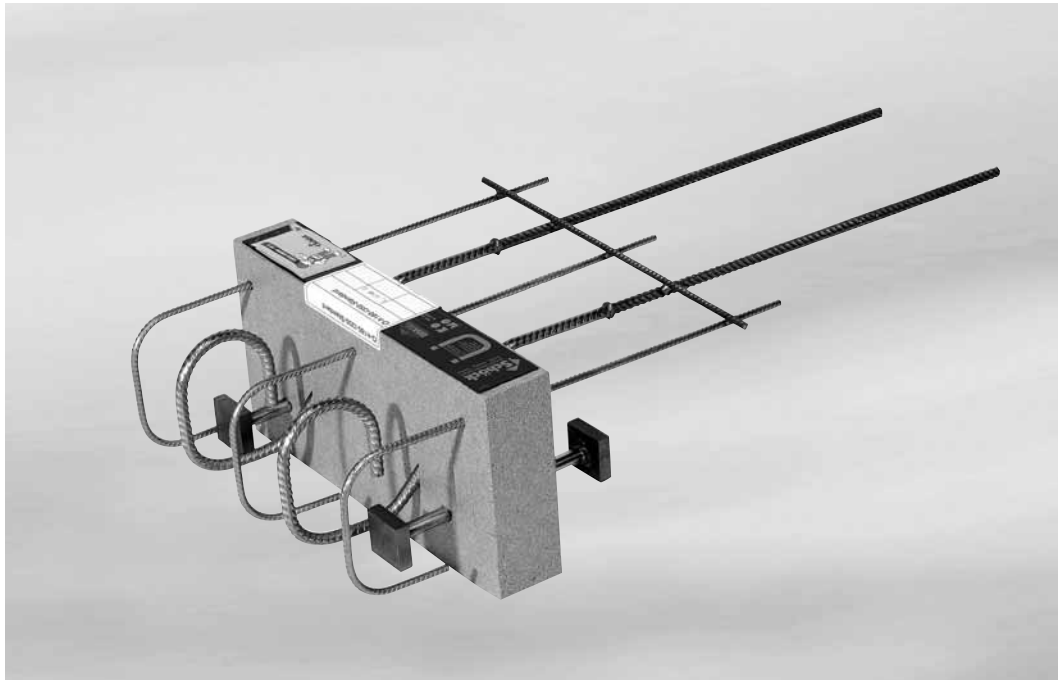

Schöck Isokorb® type 0

0

Reinforced concrete-to-reinforced concrete

Contents	Page
Element arrangement/Cross-section/Design values	106
On-site reinforcement/Expansion joint spacing/Notes	107
Connection layout	108
Method statement	109 - 110
Fire resistance	16 - 17

Schöck Isokorb® type O

Element arrangement/Cross-section/Design values

Dimensions

Isokorb® thickness	180 - 250 mm
Isokorb® length	350 mm
Insulating material thickness	60 mm

Reinforcement

Tension bars	3 ϕ 6 mm
Pressure bearings	2 ϕ 12 mm
Shear force bars	2 ϕ 10 mm

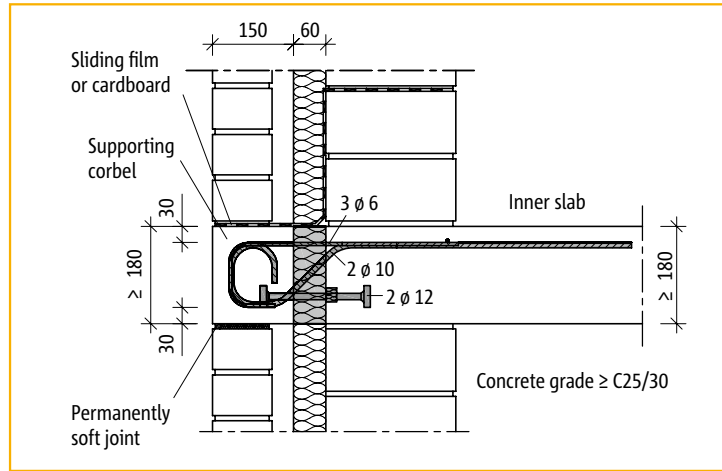

Cross-section through inner slab console and clinker mounting

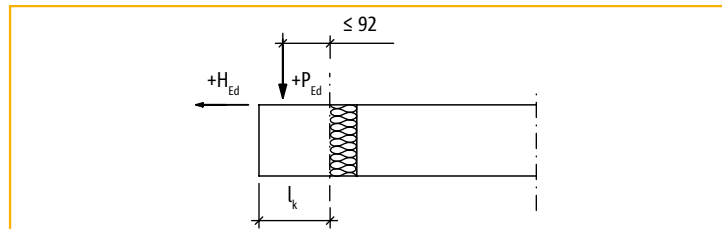

Static system

Design values for C25/30		
for	[kN/element]	
Wind-pressure	$-3.14 \leq H_{Ed} \leq 0$	$P_{Rd} = 22.56$
		at $P_{Ed} \geq +2.06 \times H_{Ed}$
Wind-suction	$0 < H_{Ed} \leq 2.26$	$P_{Rd} = 0.38 \times (59.77 - H_{Ed})$
		at $P_{Ed} \geq 10 \times H_{Ed}$

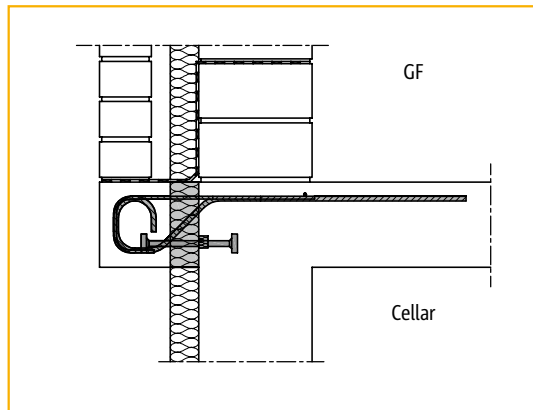

Cross-section between clinker mounting and cellar wall

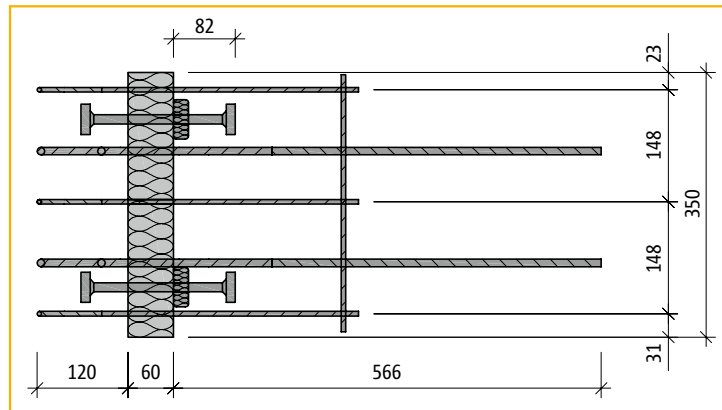

Plan view: Schöck Isokorb® type O

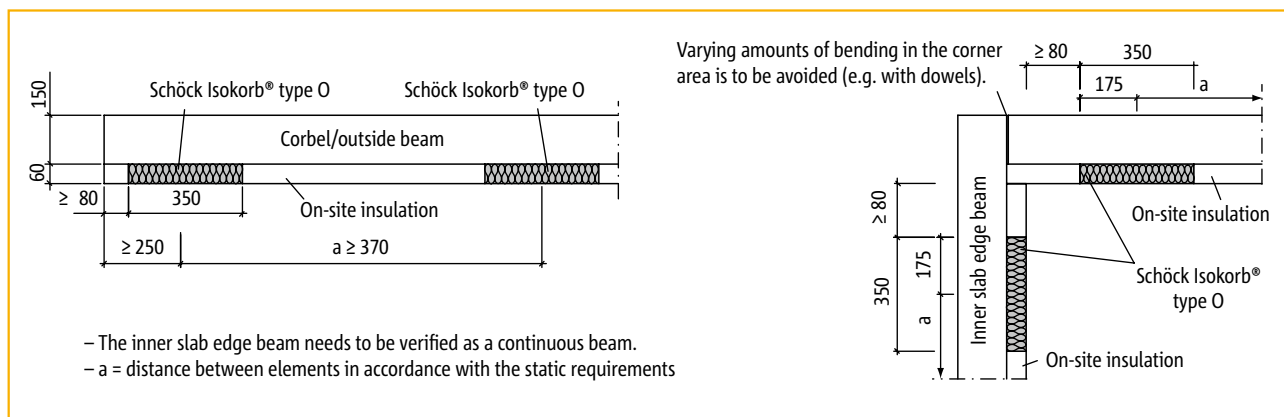

- The inner slab edge beam needs to be verified as a continuous beam.
- a = distance between elements in accordance with the static requirements

Distance between elements

Schöck Isokorb® type O

On-site reinforcement/Expansion joint spacing/Notes

On-site reinforcement

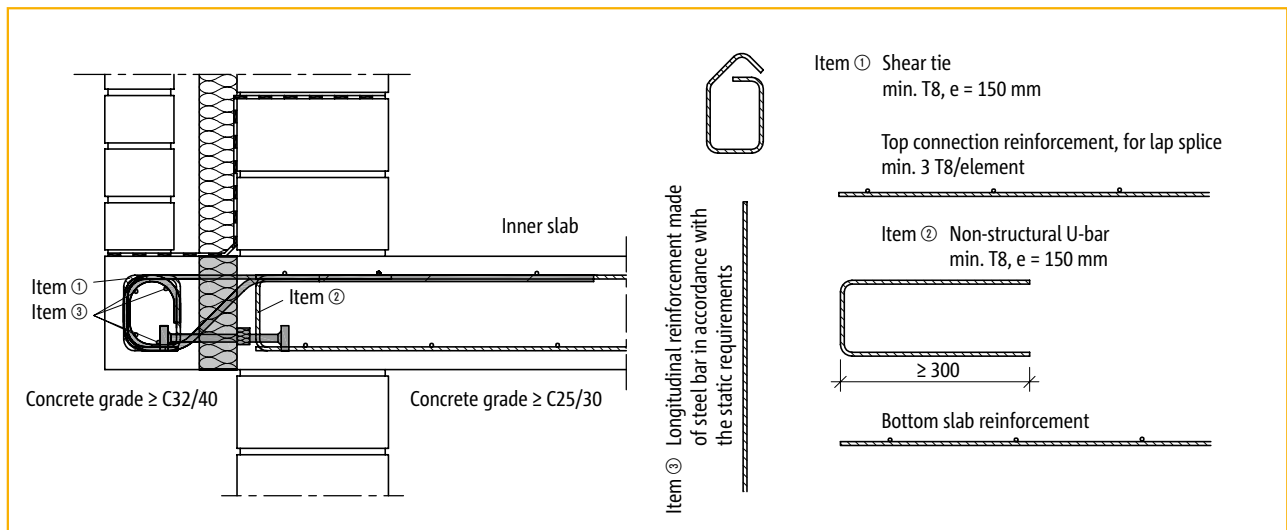

Sliding foil should be used for the bearing of the facing brickwork on the inner slab edge beam in order to prevent variations in stress. In comparison to a purely monolithic layout of the console, much greater vertical deformation takes place. This should be taken into account as required in the design and calculations of the facing brickwork.

Expansion joint spacing

The expansion joint spacing e within the edge beam, when supported by type O, is generally 7.80 m. In the case of layouts which go around a corner the max. element length is $e/2 = 3.90$ m.

Notes

- ▶ Concrete strength class for outside components at least C32/40 (see page 23).
- ▶ The inner slab edge beam needs to be verified as a continuous beam by the engineer in charge of the planning of the load-bearing structure.
- ▶ The verification of the shear force in slabs has to be provided by the structural designer according to EC2 clause 6.9.

Schöck Isokorb® type O

Connection layout

O

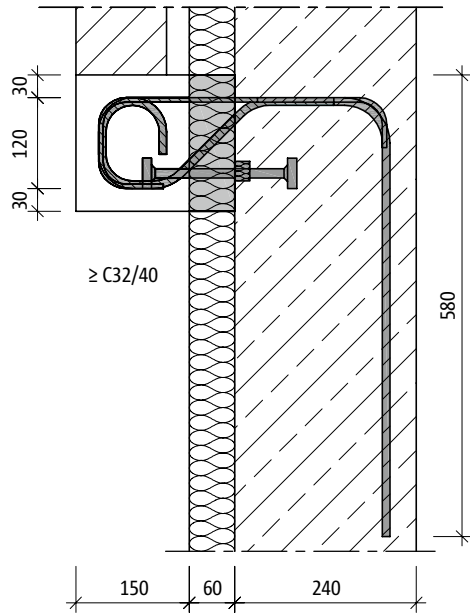

**Other special designs are available on request.
Please call us on 0845 241 3390.**

Connection of Schöck Isokorb® type O-WU 24 in the wall area without adjacent inner slab - special design

Reinforced concrete-to-reinforced concrete

Schöck Isokorb® type 0

Method statement

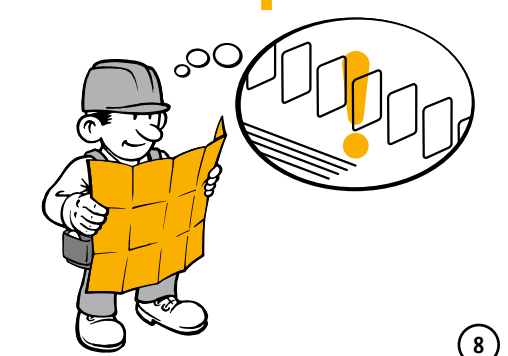
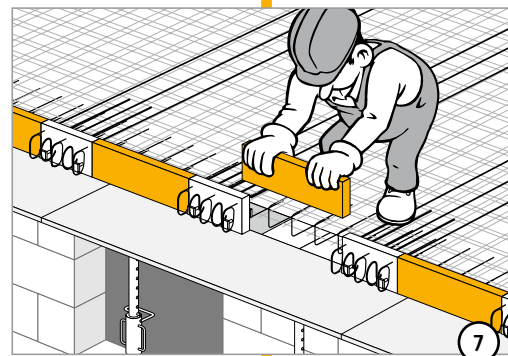
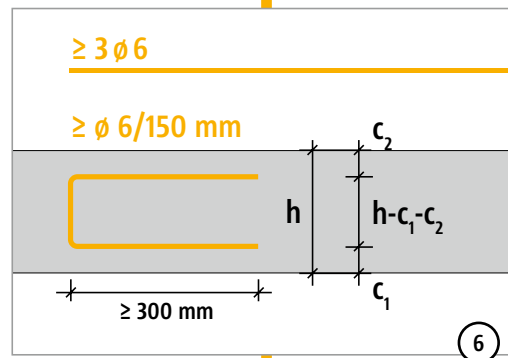
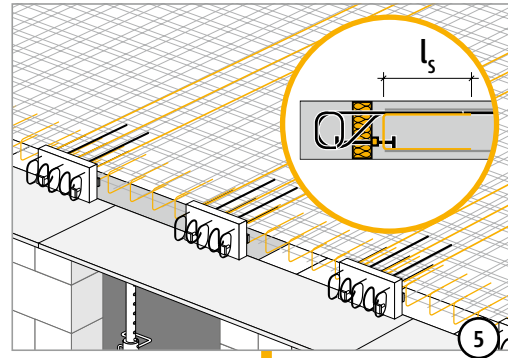
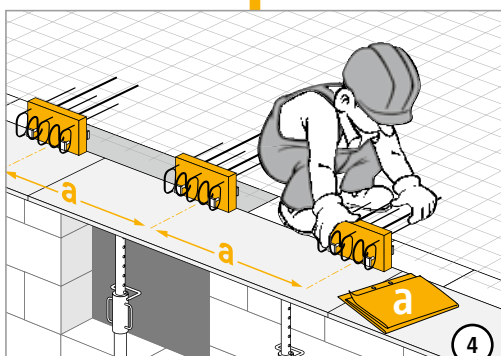
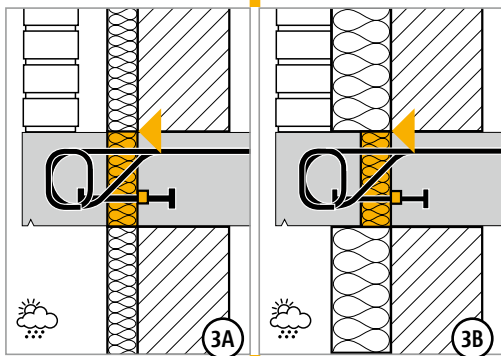
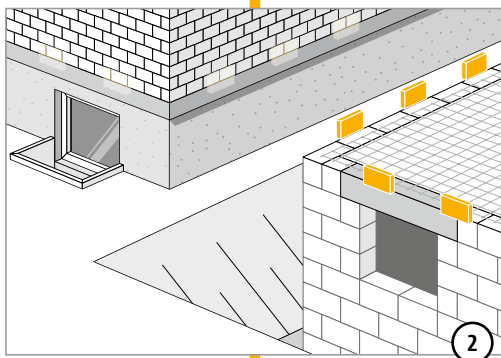
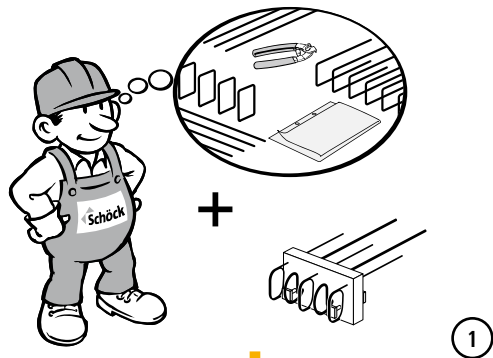

0

Reinforced concrete-to-reinforced concrete

Schöck Isokorb® type 0

Method statement

0

Reinforced concrete-to-reinforced concrete

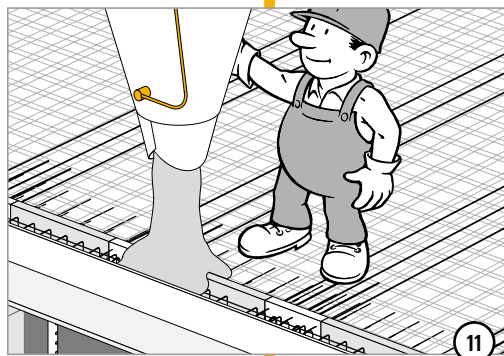
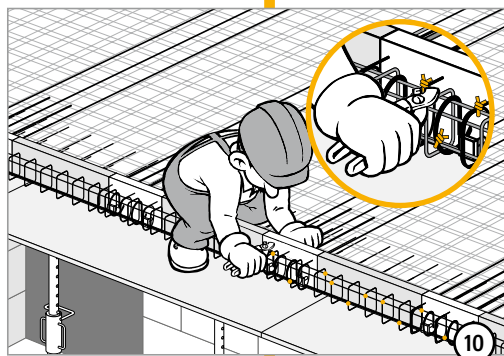
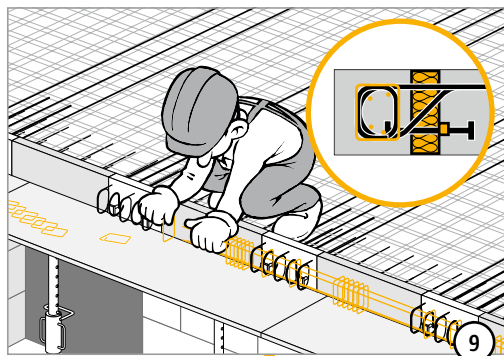

Schöck Isokorb® type F

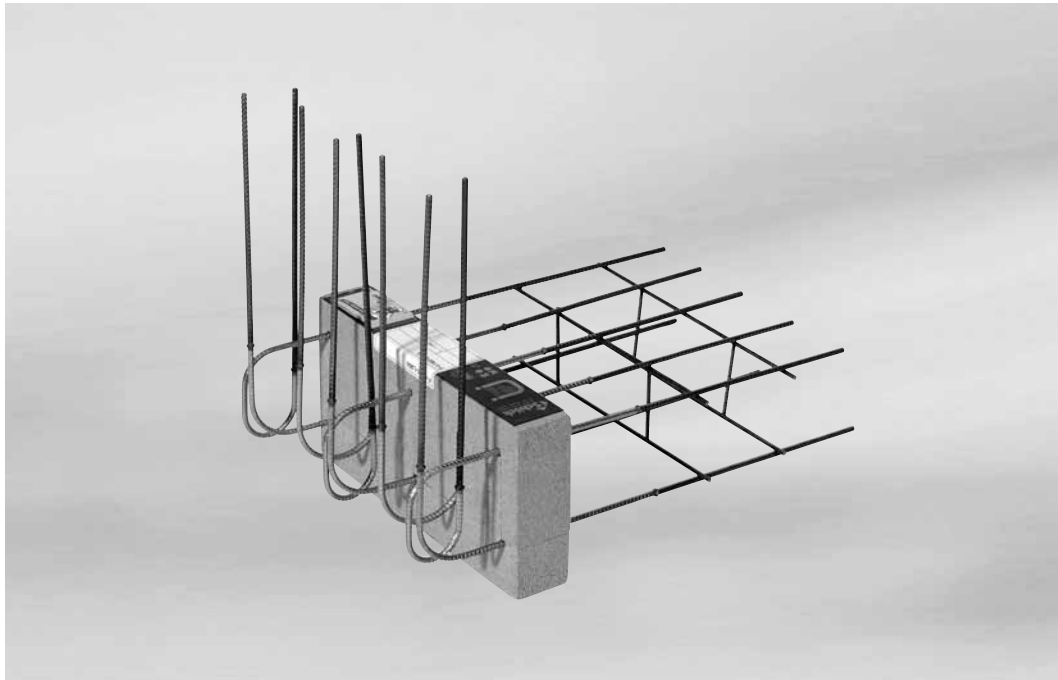

Schöck Isokorb® type F

F

Reinforced concrete-to-reinforced concrete

Contents	Page
Element arrangement/Design values/Cross-section	112
On-site reinforcement/Expansion joint spacing/Note	113
Method statement	114 - 115
Fire resistance	16 - 17

Schöck Isokorb® type F

Element arrangement/Design values/Cross-section

Dimensions

Isokorb® height	160 - 250 mm
Isokorb® length	350 mm
Insulation material thickness	60 mm

F

Reinforcement

Tension bars	3 \varnothing 6 mm
Compression bars	3 \varnothing 6 mm
Shear force bars	2 \varnothing 6 mm

Design values for \geq C25/30

V_{Rd}	= +16.0 kN per Isokorb®
M_{Rd}	$\leq \pm 2.0$ kNm per Isokorb®

Reinforced concrete-to-reinforced concrete

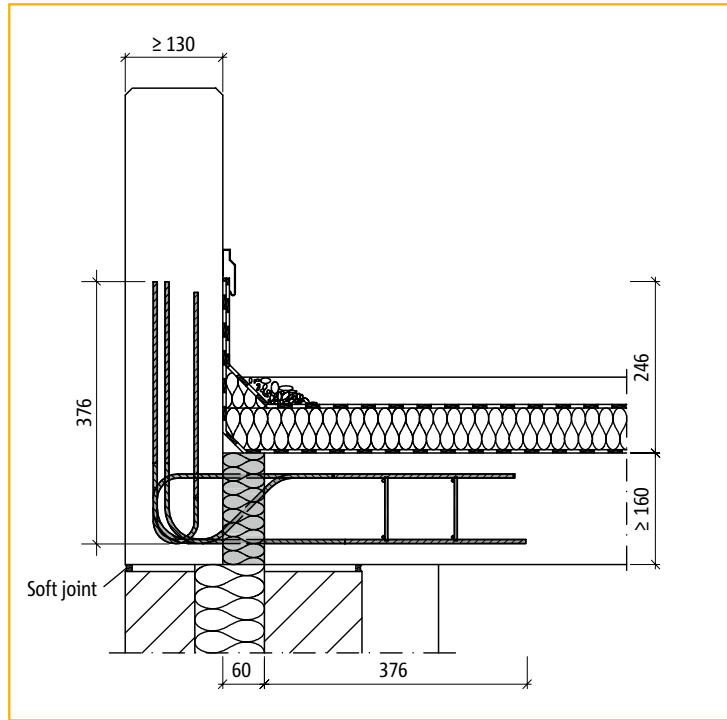

Cross-section through attic slab

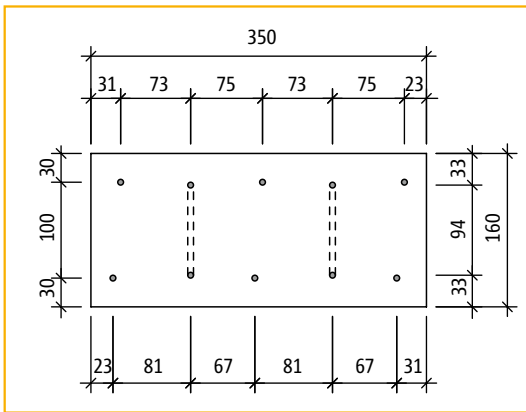

Section A - A

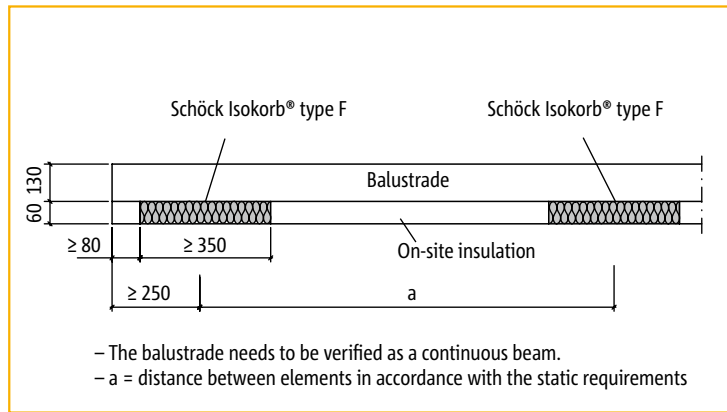

Distance between elements

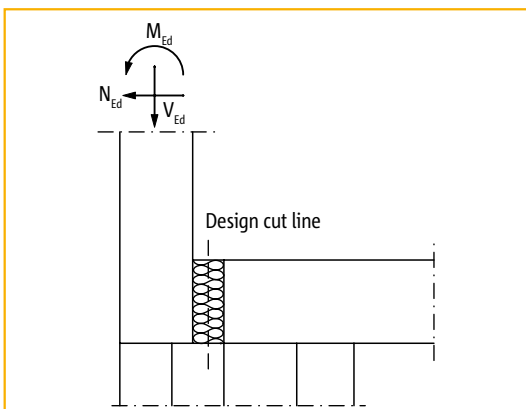

Structural system

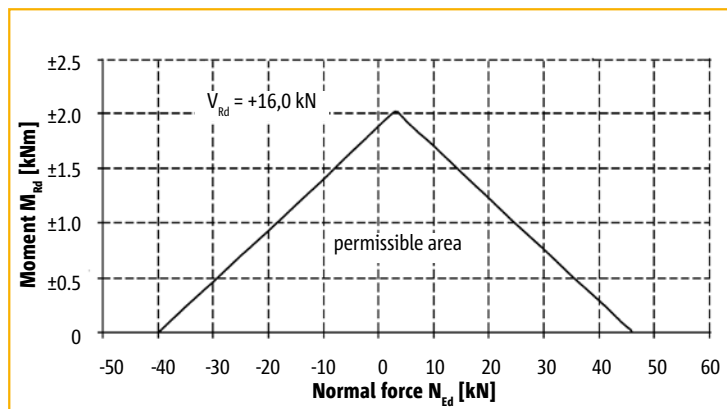

Interaction diagram for Schöck Isokorb® type F

Schöck Isokorb® type F

On-site reinforcement/Expansion joint spacing/Note

Additional on-site reinforcement

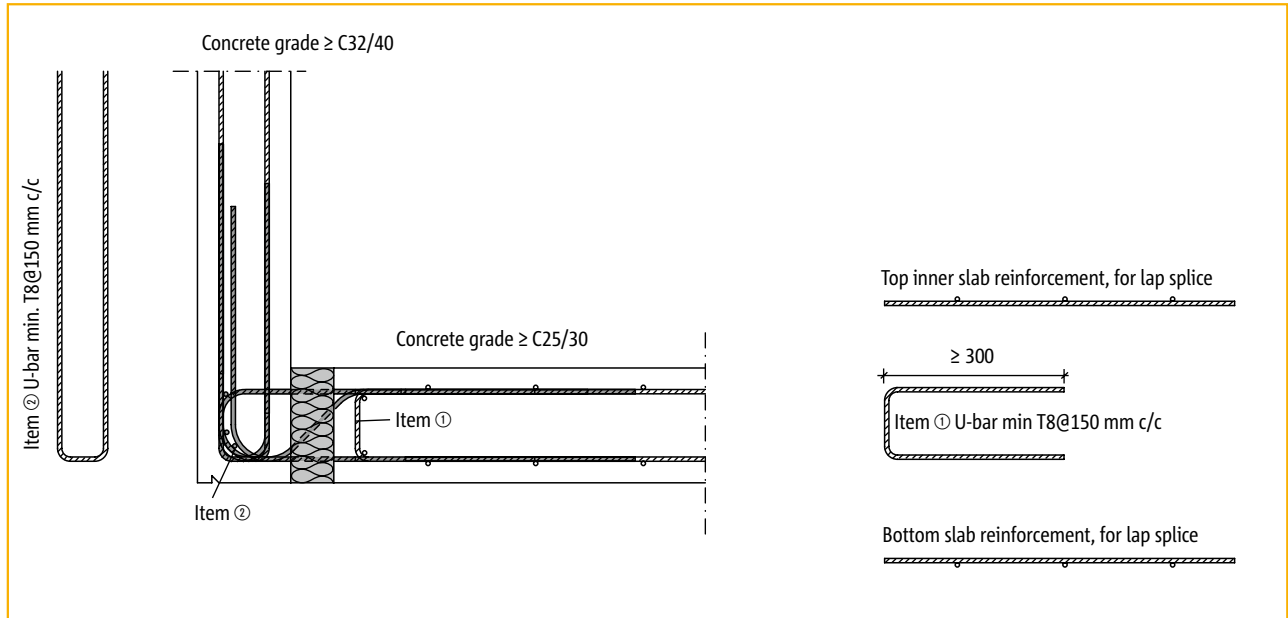

Expansion joint spacing

The expansion joint spacing e within the balustrade, when supported by type F, is generally 7.80 m. In the case of layouts which go around a corner the max. element length is $e/2 = 3.90$ m.

Note

- ▶ The verification of the shear force in slabs has to be provided by the structural designer according to EC2 clause 6.9.

F

Reinforced concrete-to-reinforced concrete

Schöck Isokorb® type F

Method statement

F

Reinforced concrete-to-reinforced concrete

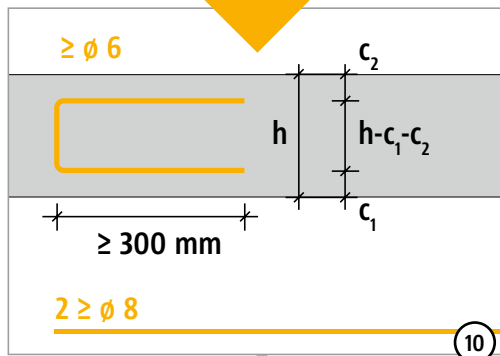
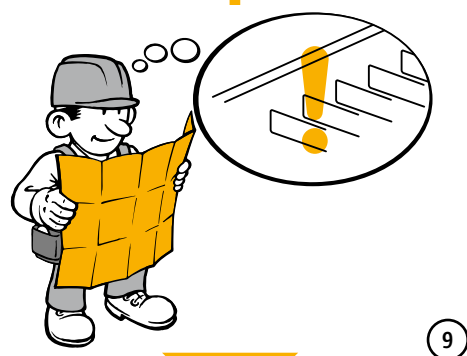
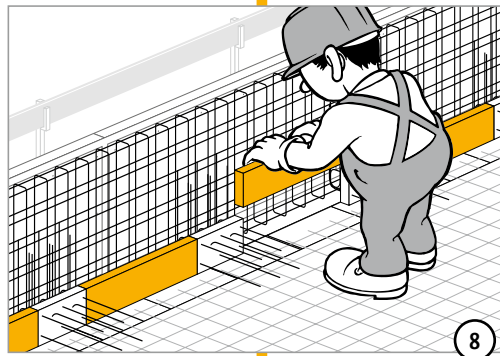
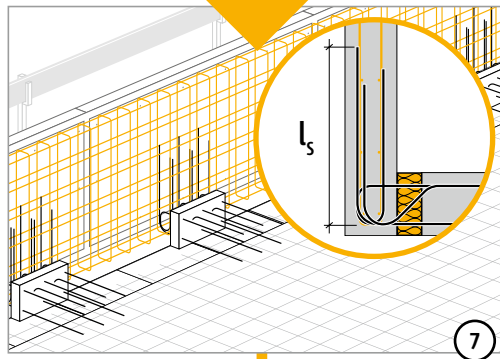
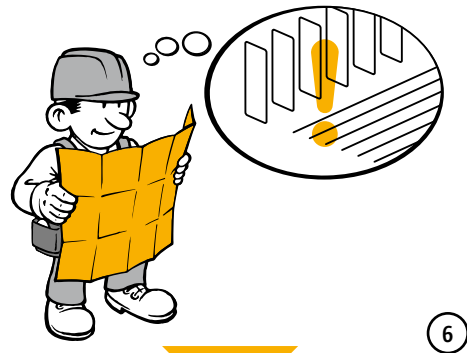
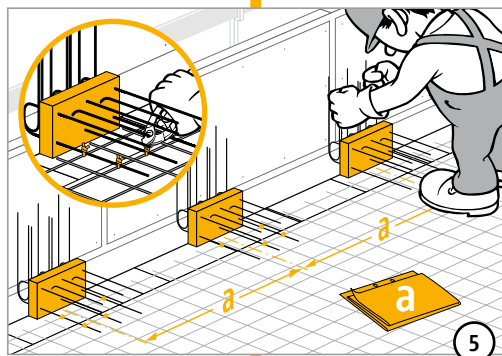
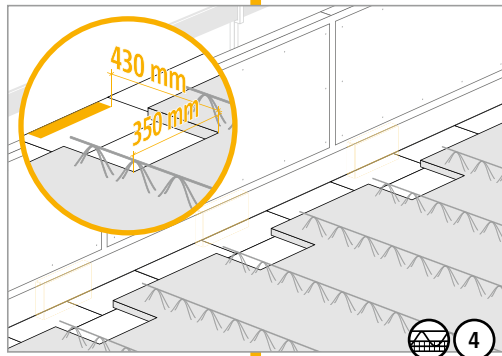
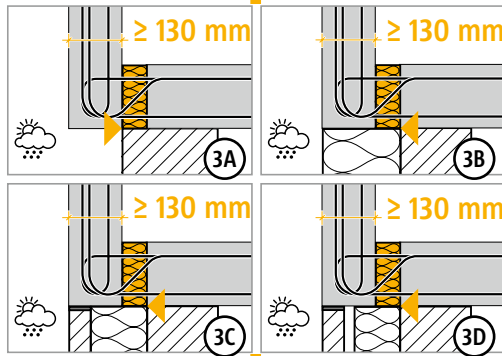
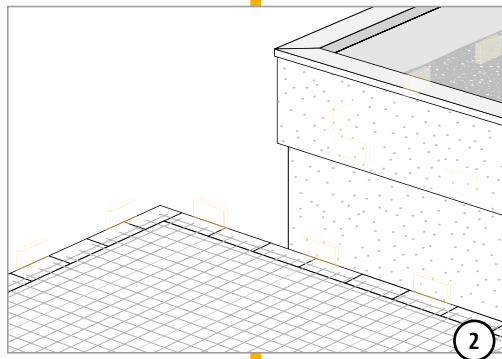
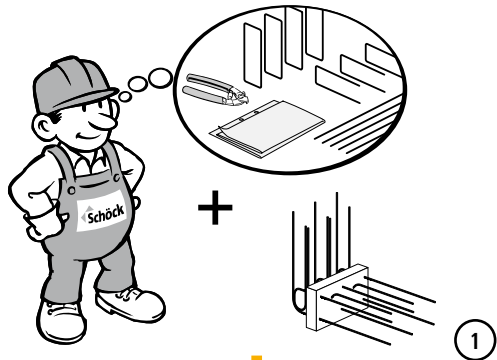

Schöck Isokorb® type F

Method statement

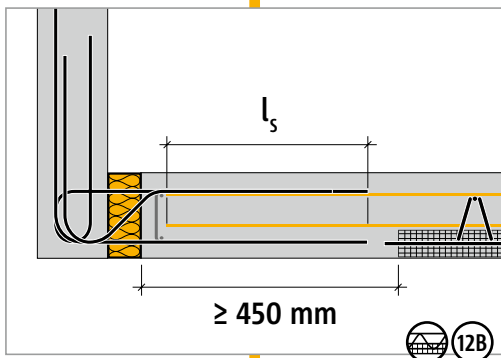
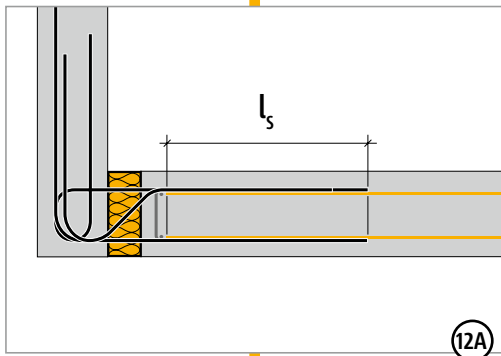
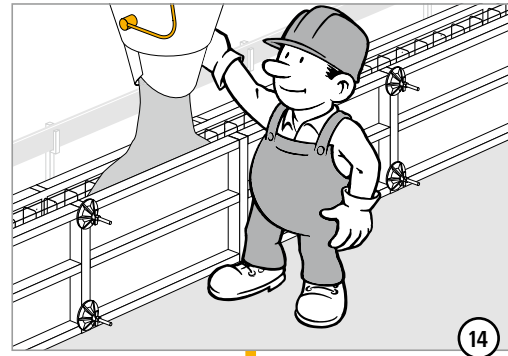
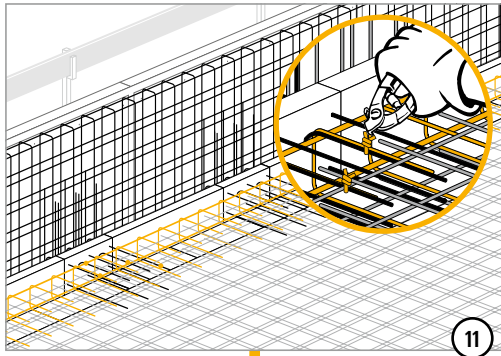

F

Reinforced concrete-to-reinforced concrete

Schöck Isokorb® type A

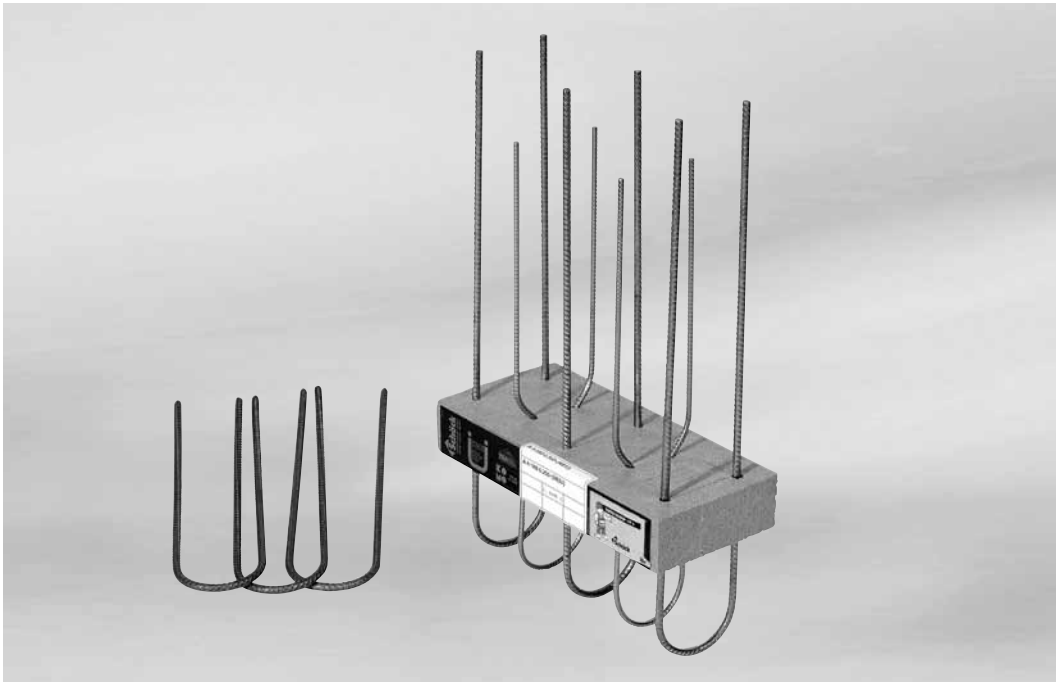

Schöck Isokorb® type A

A

Reinforced concrete-to-reinforced concrete

Contents	Page
Element arrangement/Design values/Cross-section	118
On-site reinforcement/Expansion joint spacing/Note	119
Method statement	120 - 121
Fire resistance	16 - 17

Schöck Isokorb® type A

On-site reinforcement/Expansion joint spacing/Note

Additional on-site reinforcement

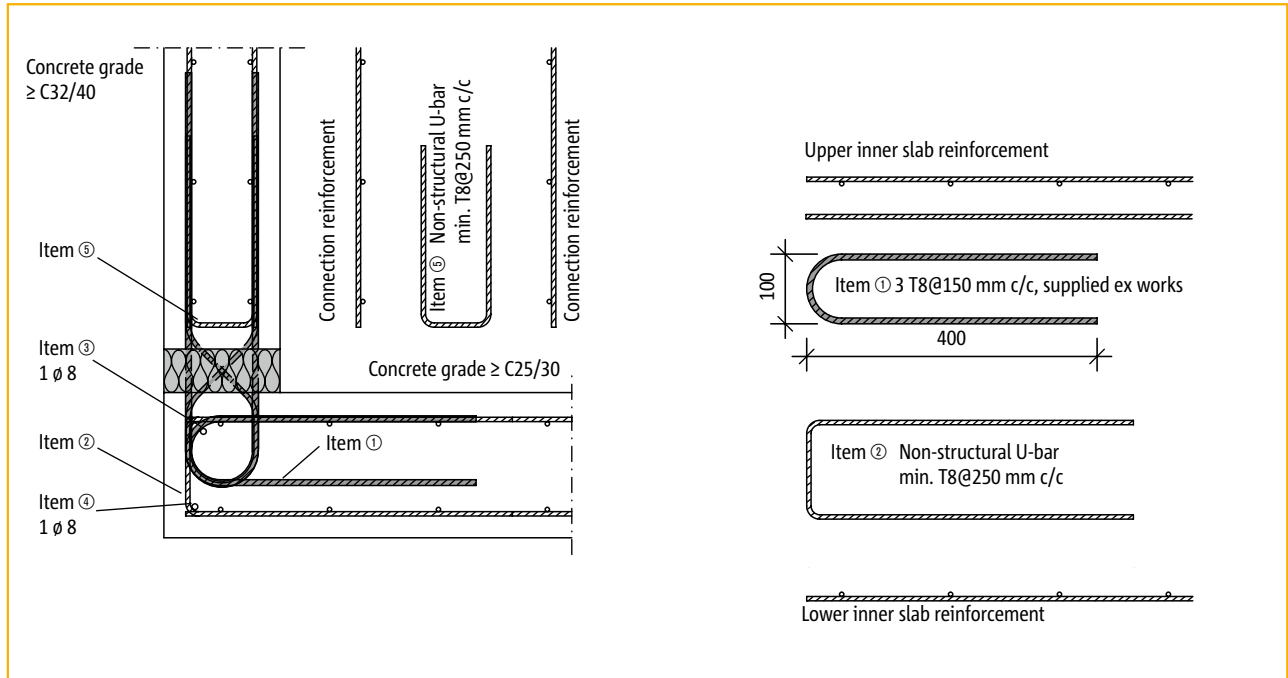

Expansion joint spacing

The expansion joint spacing e within the balustrade, when supported by type A, is generally 7.80 m. In the case of layouts which go around a corner the max. element length is $e/2 = 3.90$ m.

Note

- ▶ The verification of the shear force in slabs has to be provided by the structural designer according to EC2 clause 6.9.

A

Reinforced concrete-to-reinforced concrete

Schöck Isokorb® type A

Method statement

A

Reinforced concrete-to-reinforced concrete

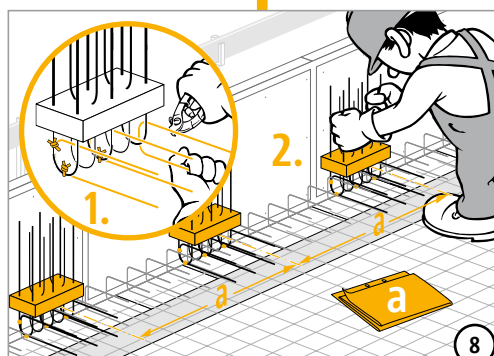
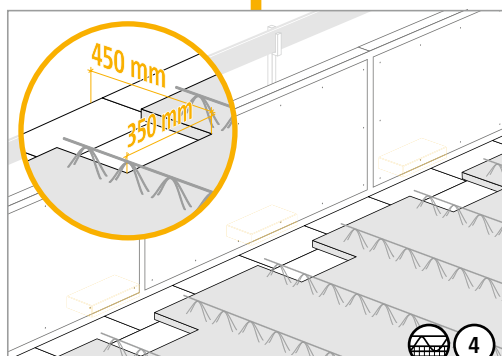
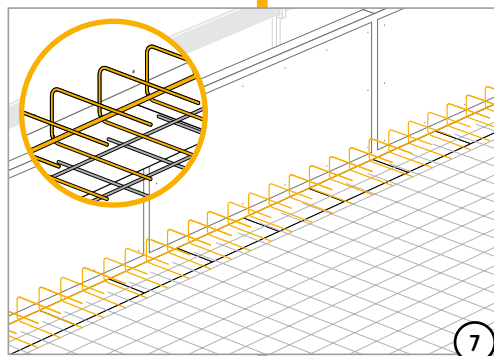
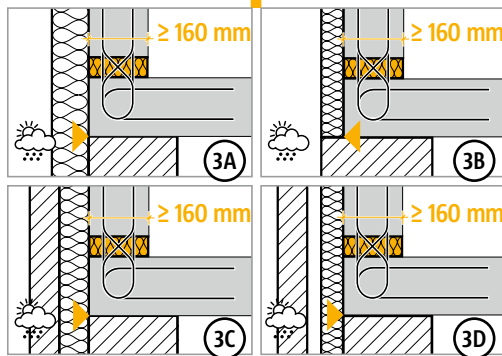
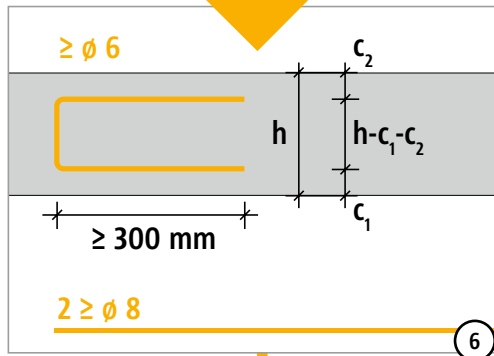
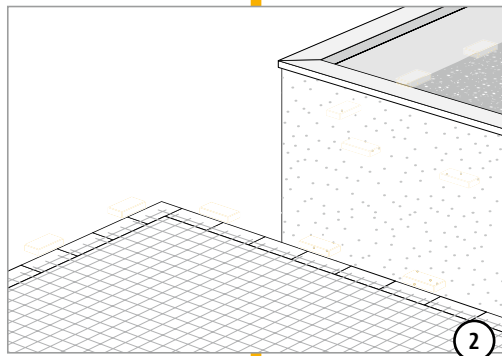
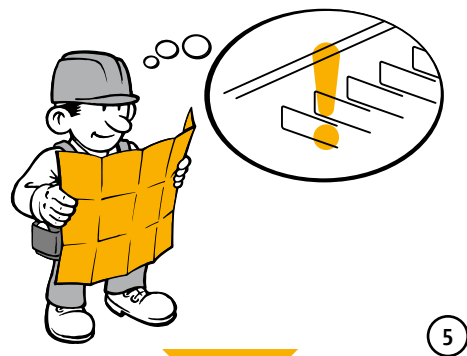
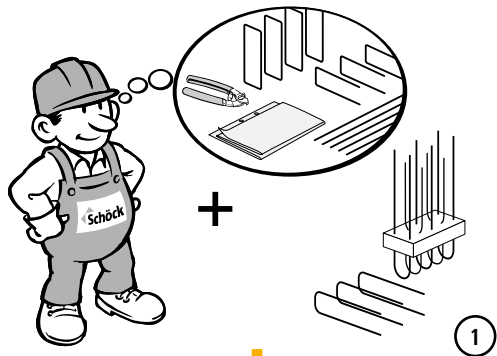

Schöck Isokorb® type A

Method statement

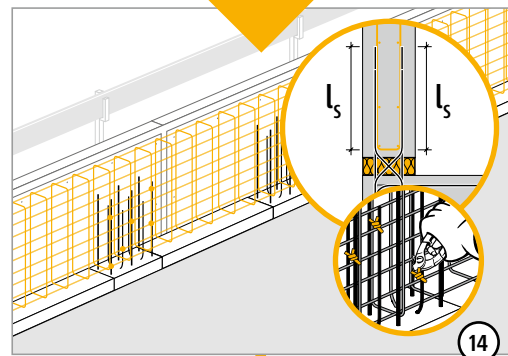
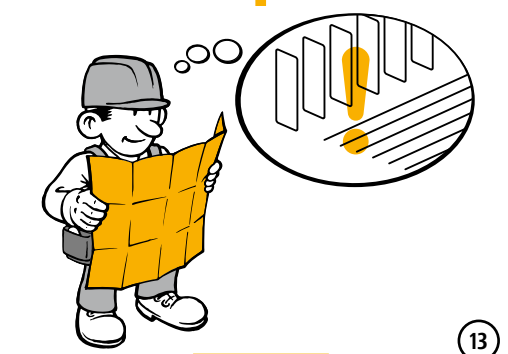
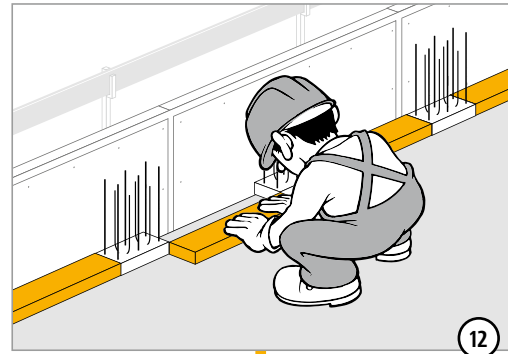
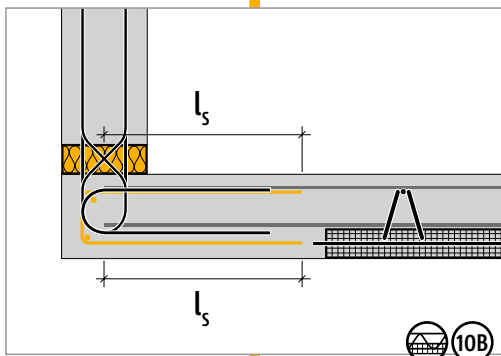
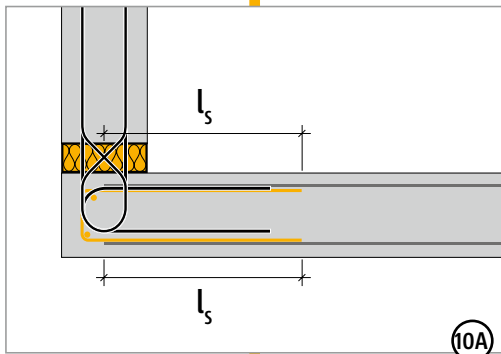
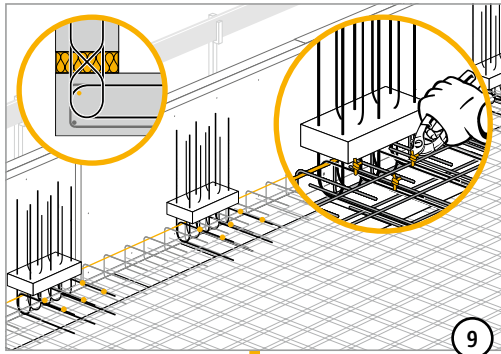

A

Reinforced concrete-to-reinforced concrete

Schöck Isokorb® type S

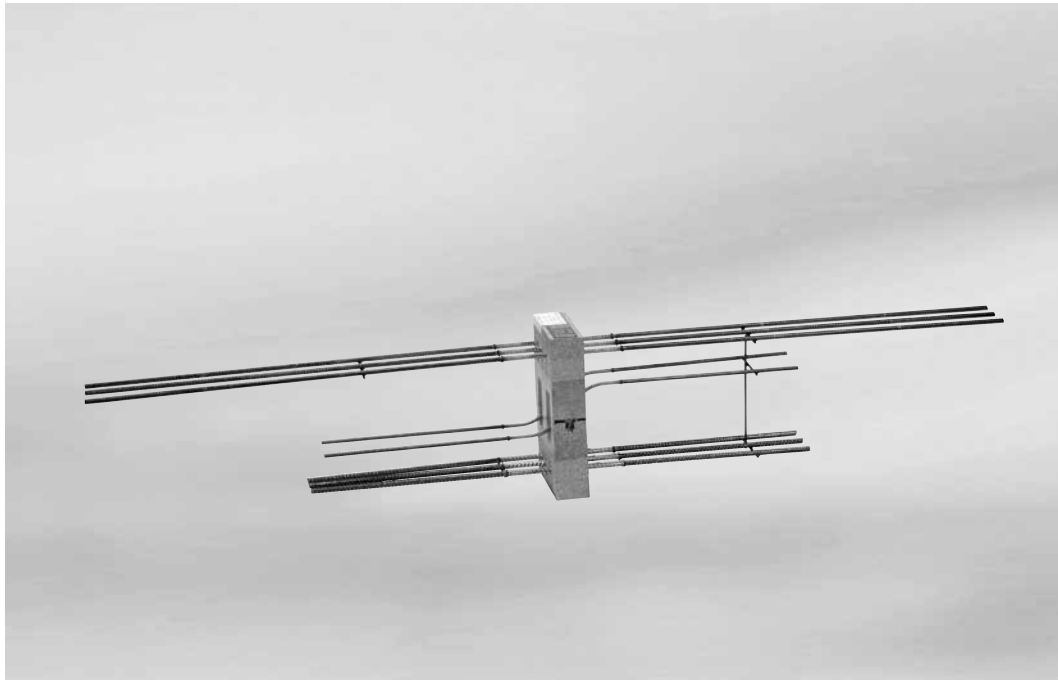

Schöck Isokorb® type S

S

Reinforced concrete-to-reinforced concrete

Contents	Page
Cross-section/Element arrangement/Capacity table	124
On-site reinforcement/Expansion joint spacing/Note	125
Method statement	126 - 127
Fire resistance	16 - 17

Schöck Isokorb® type S

Cross-section/Element arrangement/Capacity table

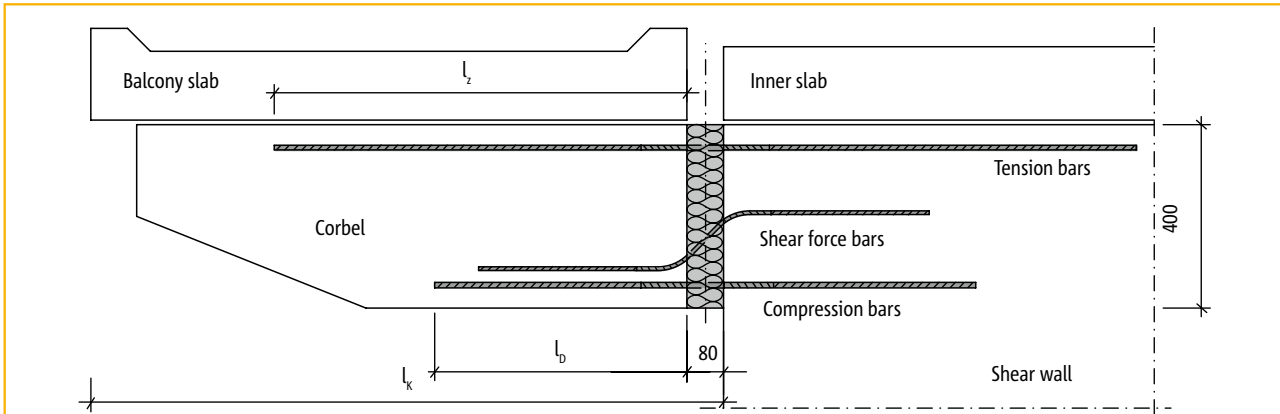

Cross-section

Dimensions

Isokorb® width $B = 220$ mm
 Isokorb® height $H = 400$ mm
 Insulation material thickness $T = 80$ mm

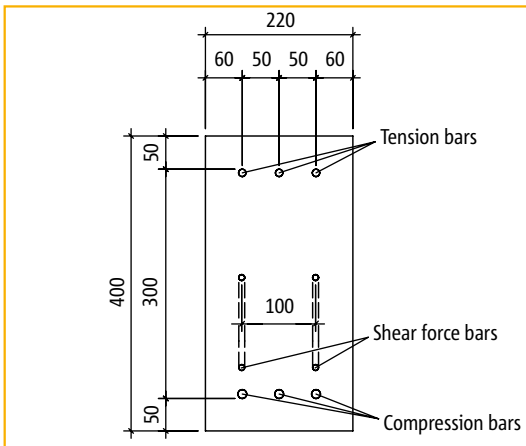

View

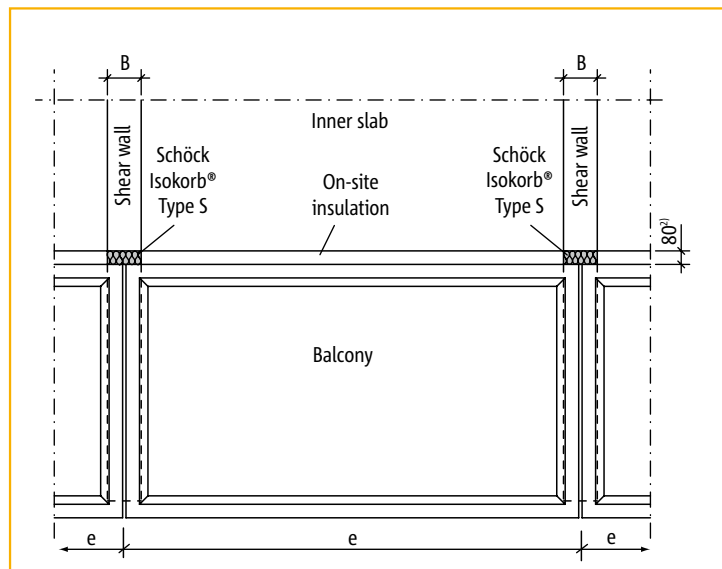

Plan view: Element arrangement

Capacity table for $\geq C25/30$. Concrete grade for outside components $\geq C32/40$.

Schöck Isokorb® type	Reinforcement	High bond condition (standard version)		Low bond condition area II		M_{Rd} [kNm]	V_{Rd} [kN]	Mounting reinf. item ③ req. A_s [mm ²]
		l_z [mm]	l_b [mm]	l_z [mm]	l_b [mm]			
S1	3 ϕ 10 tension bars 2 ϕ 8 Q-bars 3 ϕ 12 compression bars	595	595	905	595	-27.5	+24.9	57
S2	3 ϕ 12 tension bars 2 ϕ 10 Q-bars 3 ϕ 14 compression bars	740	565	1060	565	-37.0	+38.9	89
S3	3 ϕ 14 tension bars 2 ϕ 12 Q-bars 3 ϕ 16 compression bars	850	635	1220	635	-48.1	+56.0	129
S4	3 ϕ 16 tension bars 2 ϕ 14 Q-bars 3 ϕ 20 compression bars	1340	785	1870	785	-75.7	+76.2	175

The determination of the anchoring lengths is based on bond area I. The reinforcing bars can also be designed according to bond area II on request.

Schöck Isokorb® type S Standard is used as an example for a potential application. For other solutions please contact our Technical Design Department on 0845 241 3390.

Schöck Isokorb® type S

On-site reinforcement/Expansion joint spacing/Note

Additional on-site reinforcement

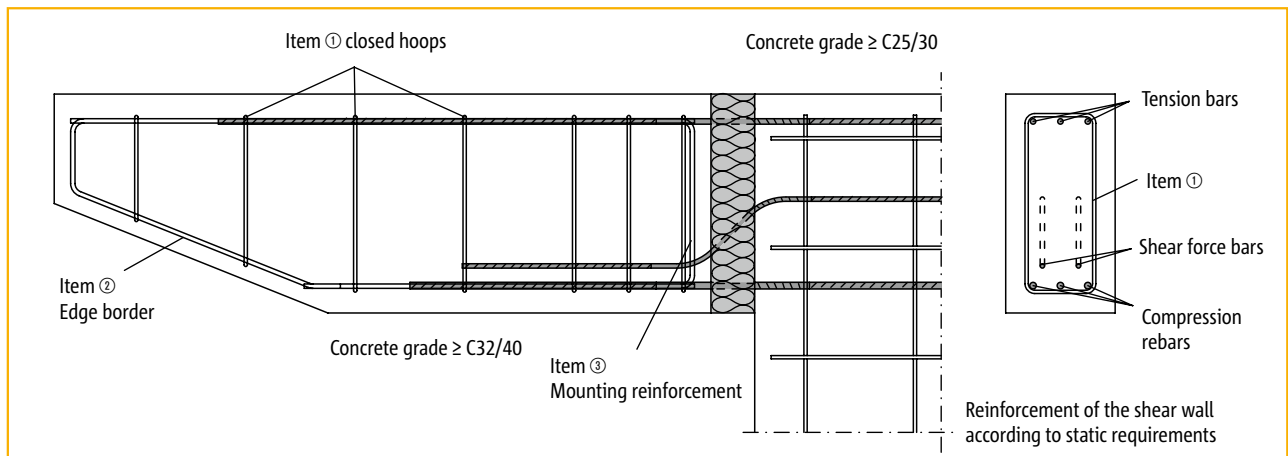

Expansion joint spacing e in [m]

Insulation material thickness [mm]	Schöck Isokorb® type			
	S1	S2	S3	S4
80	11.3 m	10.1 m	9.2 m	8.0 m

In the case of layouts which go around a corner the max. spacing between corner and edge of balcony slab is $e/2$.

The spacing between expansion joints can be increased if there is no fixed connection between balcony slab and cantilever beam, e.g. by inserting a sliding foil.

Note

- The verification of the shear force in slabs has to be provided by the structural designer according to EC2 clause 6.9.

Schöck Isokorb® type S

Method statement

S

Reinforced concrete-to-reinforced concrete

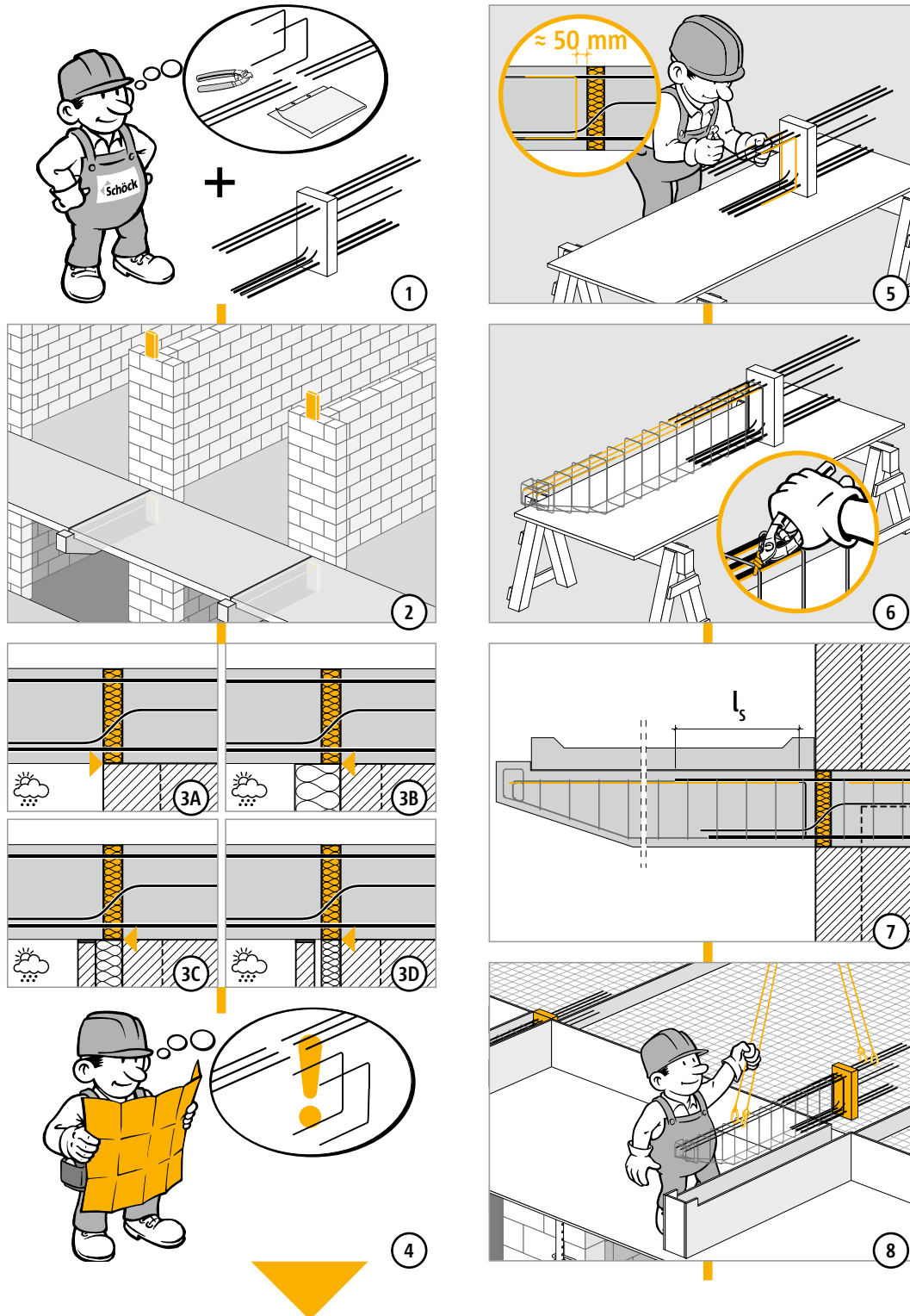

Schöck Isokorb® type S

Method statement

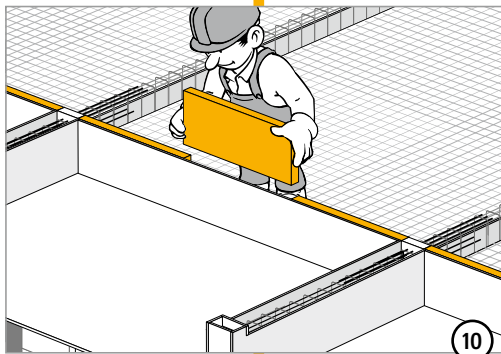
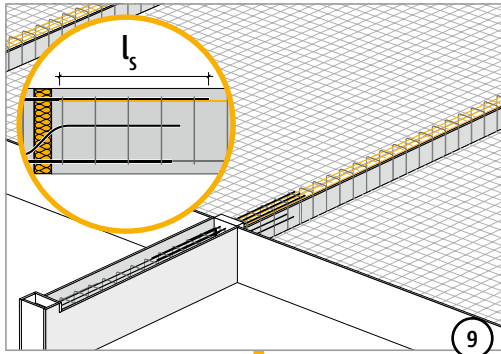

S

Reinforced concrete-to-reinforced concrete

Schöck Isokorb® type W

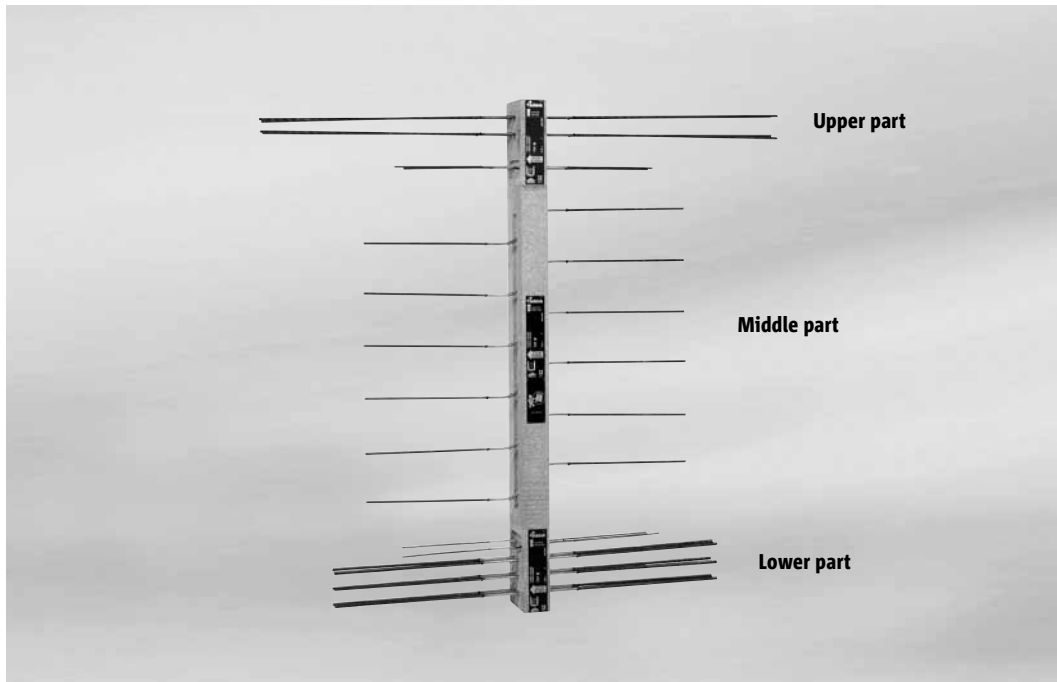

Schöck Isokorb® type W

W

Reinforced concrete-to-reinforced concrete

Contents	Page
Cross-section/Element arrangement/Capacity table	130
On-site reinforcement/Expansion joint spacing/Note	131
Method statement	132 - 133
Fire resistance	16 - 17

Schöck Isokorb® type W

Cross-section/Element arrangement/Capacity table

Dimensions

Available Isokorb® width
B = 150 - 250 mm

Available Isokorb® height
H = 1.5 - 3.5 m

Insulation material thickness
T = 80 mm

Please specify your required dimensions when placing an order. Other dimensions available on request.

Schöck Isokorb® type W comprises at least three partial elements: Lower part, middle part and upper part.

Depending on the structural requirements, 1 of 4 standard elements can be chosen (see table).

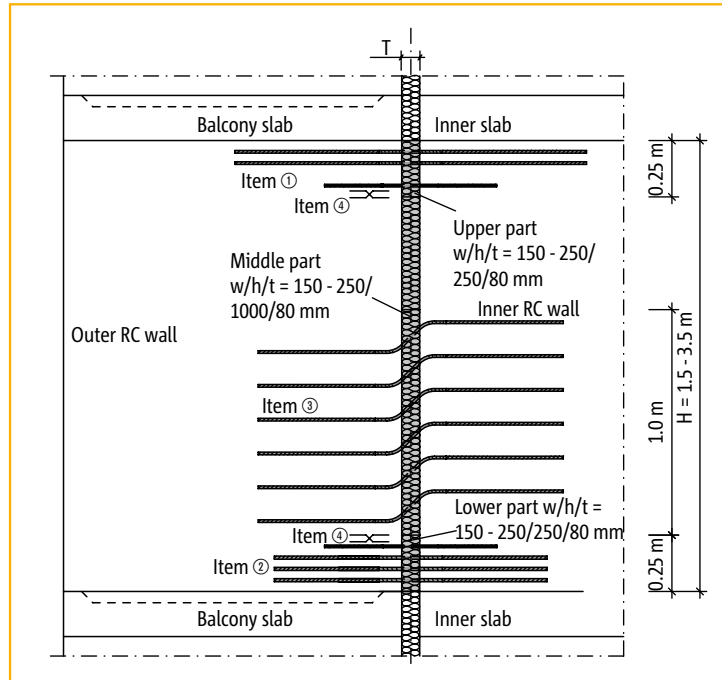

Cross-section

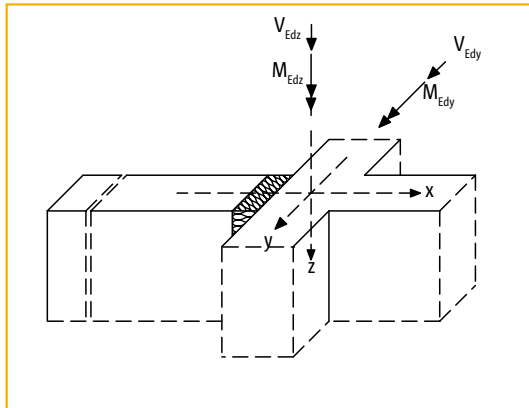

View

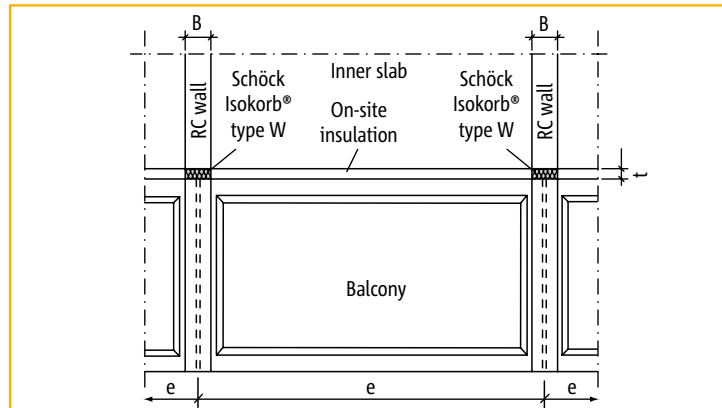

Plan view: Element arrangement

Capacity table for \geq C25/30. Concrete grade for outside components \geq C32/40.

Schöck Isokorb® type	Reinforcement			Design values					
	Tensile force	Compression	Shear force	M_{Rdy} [kNm]			V_{Rdz} [kN]	Mounting reinf. Item ① req. A_s [mm ²]	
	Item ①	Item ②	Item ③ + ④	Height 1.5 - 2.0 m	Height 2.0 - 2.5 m	Height > 2.5 m			
W1	4 ϕ 6	6 ϕ 8	6 ϕ 6 2 x 2 ϕ 6	-62.7	-86.3	-110.0	+42.0	97	
W2	4 ϕ 8	6 ϕ 10	6 ϕ 8 2 x 2 ϕ 6	-107.8	-148.5	-189.2	+74.6	172	
W3	4 ϕ 10	6 ϕ 12	6 ϕ 10 2 x 2 ϕ 6	-153.9	-212.0	-270.1	+116.6	268	
W4	4 ϕ 12	6 ϕ 14	6 ϕ 12 2 x 2 ϕ 6	-207.6	-285.9	-364.2	+143.1	386	
				$M_{Rdz} = 0$ $V_{Rdy} = \pm 14.0$ kN (resulting e.g. from wind loads)					

Moments arising as a result of wind loads are absorbed by the stiffening effect of the balcony slabs. The determination of the anchoring lengths is based on bond area II.

Schöck Isokorb® type W Standard is used as an example for a potential application. For other solutions please contact our Technical Design Department on 0845 241 3390.

Reinforced concrete-to-reinforced concrete

W

Schöck Isokorb® type W

On-site reinforcement/Expansion joint spacing/Note

Additional on-site reinforcement

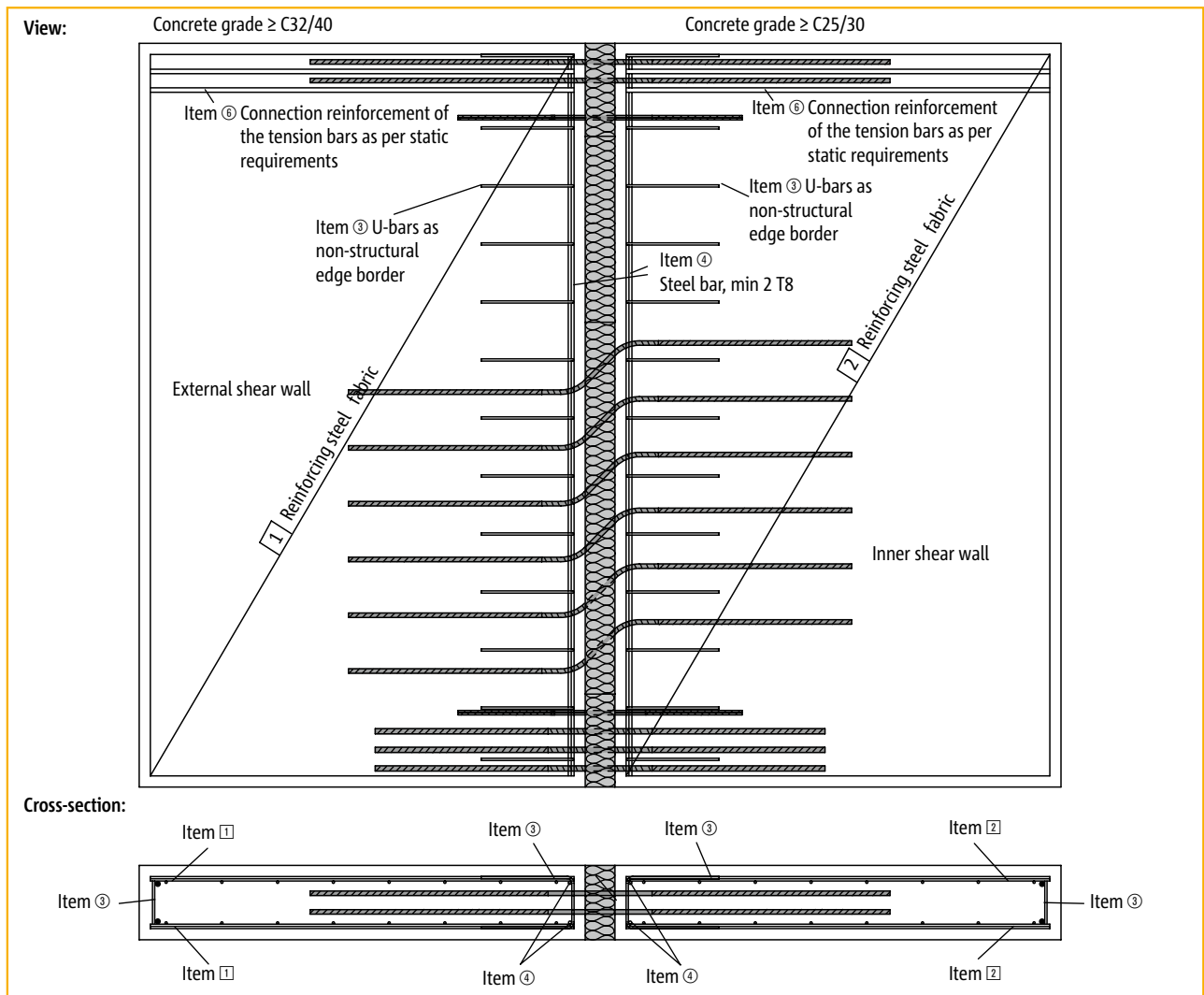

W

Reinforced concrete-to-reinforced concrete

Expansion joint spacing e in [m]

Insulation material thickness [mm]	Expansion joint spacing e [m]
80	10.1

The spacing between expansion joints can be increased if there is no fixed connection between balcony slab and shear wall, e.g. by inserting a sliding foil.

Note

- ▶ Concrete strength class for outside components at least C32/40 (see page 23).

Schöck Isokorb® type W

Method statement

W

Reinforced concrete-to-reinforced concrete

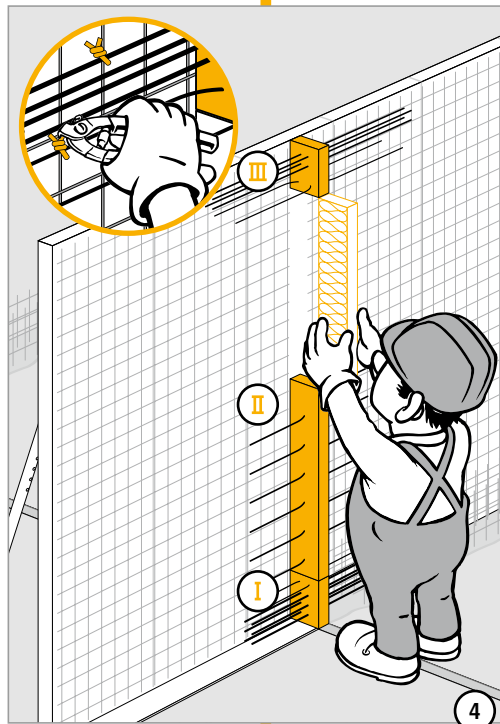
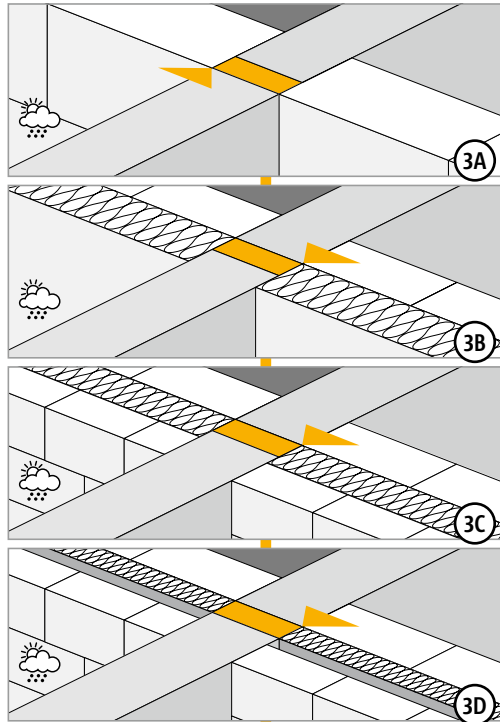
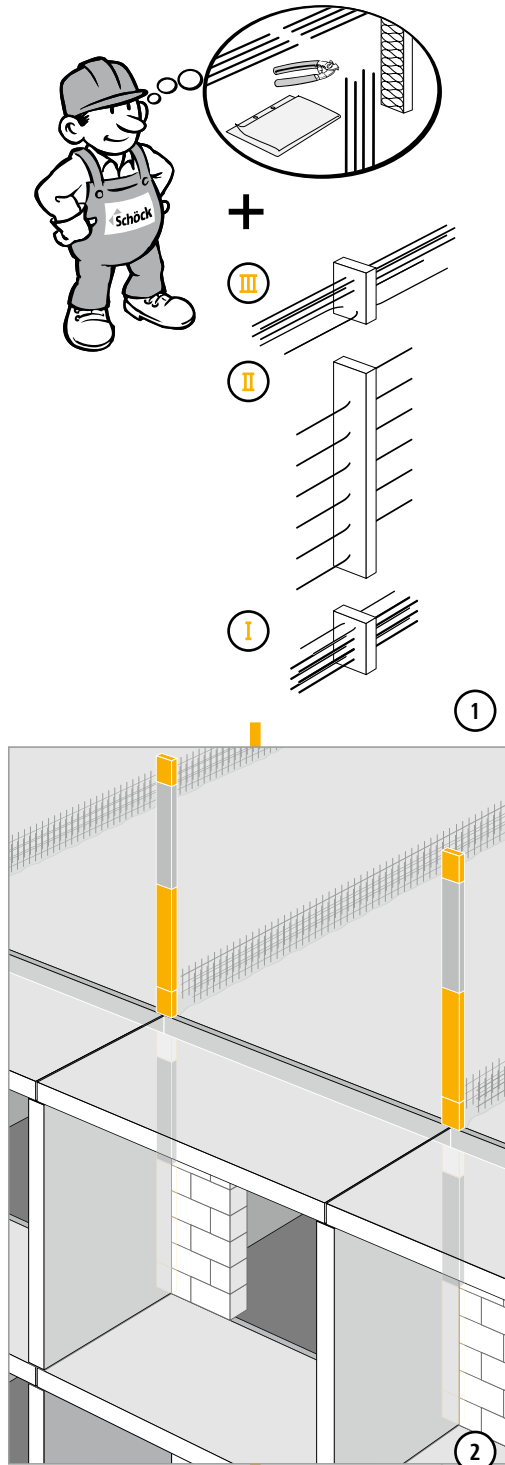

Schöck Isokorb® type W

Method statement

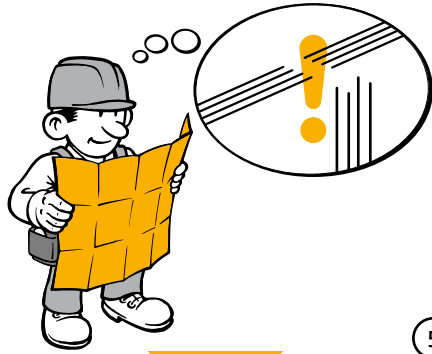

5

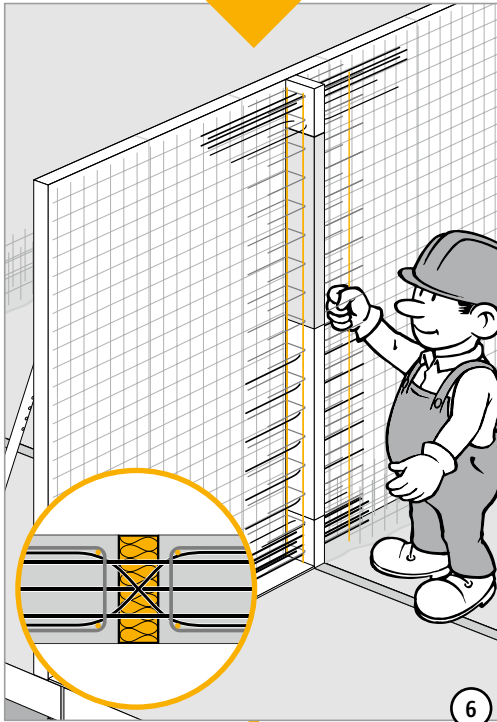

6

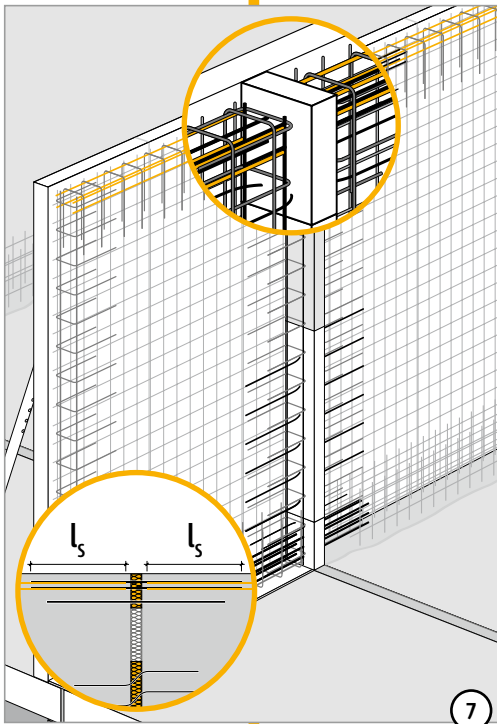

7



8



W

Reinforced concrete-to-reinforced concrete

Schöck Isokorb®

Construction details

Connection in the door area

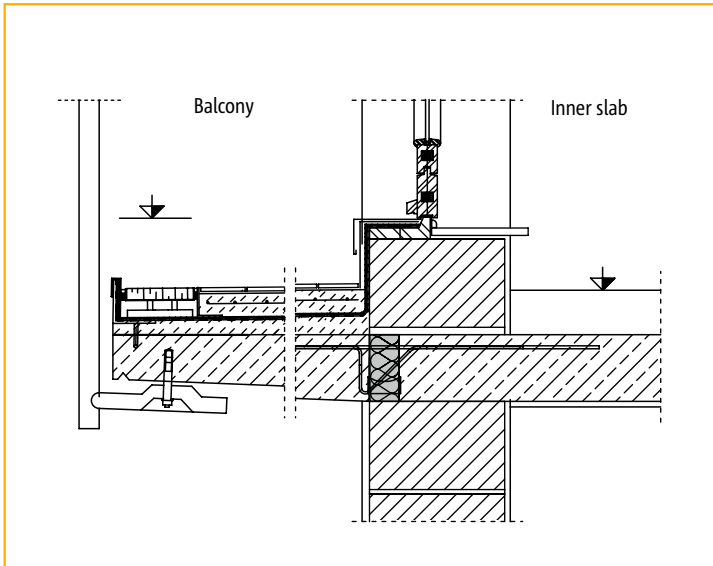

An additional insulating strip should be inserted in order to avoid thermal bridges in the area of the door.

Connection with a cavity wall structure

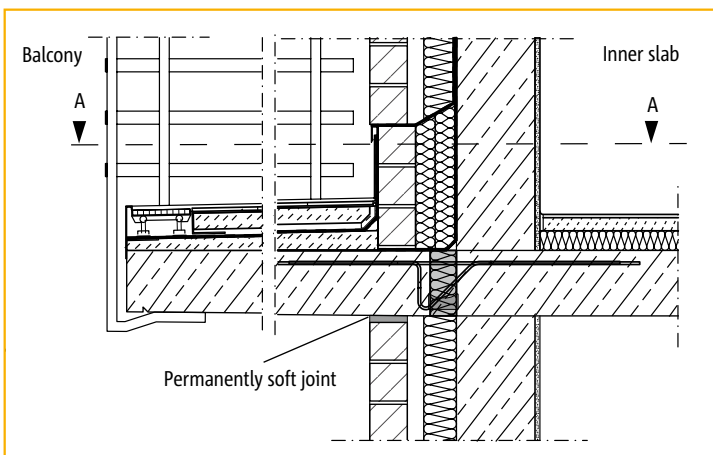

Continuous expansion joints should be arranged in order to prevent cracks in the facing shell.

Cross-section B – B

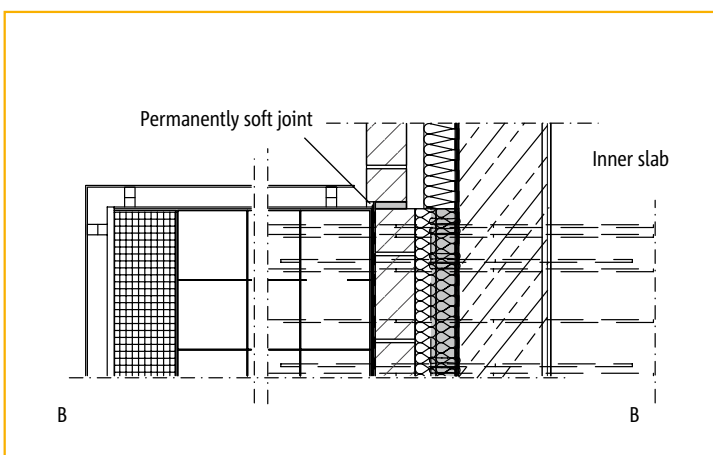

Cross-section A – A, plan view

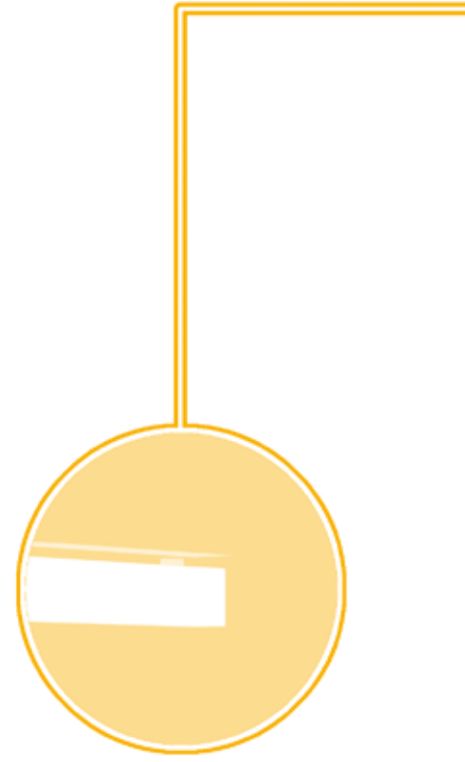

Schöck Isokorb® type KS

Page 139



for the connection of cantilevered steel beams
to reinforced concrete.

Schöck Isokorb® type QS

Page 159



for the connection of supported steel beams
to reinforced concrete.

Schöck Isokorb® type KS

Materials/Anti-corrosion protection/Fire protection/Designations

Schöck Isokorb® type KS - materials

Concrete	Minimum concrete grade C25/30 on the inner slab side
Reinforcing steel	B 500 B acc. to BS 4449, and BSt 500 NR
Pressure bearings in the concrete	S 235 JRG 2, S 355 JO
Stainless steel	Material no.: 1.4401, 1.4404, 1.4462 or 1.4571, S460 according to approval no.: Z-30.3-6 Components and connecting devices made of stainless steels
Pressure plate for external application	Material no.: 1.4404, 1.4362 and 1.4571 or higher grade, e.g. 1.4462, S 460
Spacer shims	Material no.: 1.4401, S 235, thickness 2 mm and 3 mm
Insulating material	Polystyrene hard foam (Neopor ^{®1)}), $\lambda = 0.031 \text{ W}/(\text{m} \times \text{K})$

Anti-corrosion protection

- ▶ The stainless steel used for Schöck Isokorb® type KS corresponds to the material no.: 1.4401, 1.4404, 1.4571 or 1.4462. So the KS unit components will have a typical corrosion resistance expected for Mo-Cr-Ni austenitic stainless steels. This can be more accurately quantified by reference to specialist literature such as SCI Publication P291 – Structural Design of Stainless Steel.
- ▶ Bimetallic corrosion
Using Schöck Isokorb® type KS in conjunction with a galvanised or paint treated end plate there is no concern regarding bimetallic corrosion. Since in this application the area of the galvanised steel is greater than the area of the stainless steel (bolts, washer and butt stop) bimetallic corrosion that could lead to failure can be excluded as far as this relates to the Schöck products.

Fire protection

The same on-site fire safety measures that apply to the overall load-bearing structure also apply to any freely accessible components of the Schöck Isokorb® type KS or to any components situated inside the insulating layer.
For more information please contact our design department on 0845 241 3390.

Designations used in planning documents

(structural calculations, specification documents, implementation, order), e.g. for H = 180 mm

Schöck Isokorb® type **KS14-H180**

Type + load range

Height of Isokorb

¹⁾ Neopor is a registered brand name of BASF

Schöck Isokorb® type KS

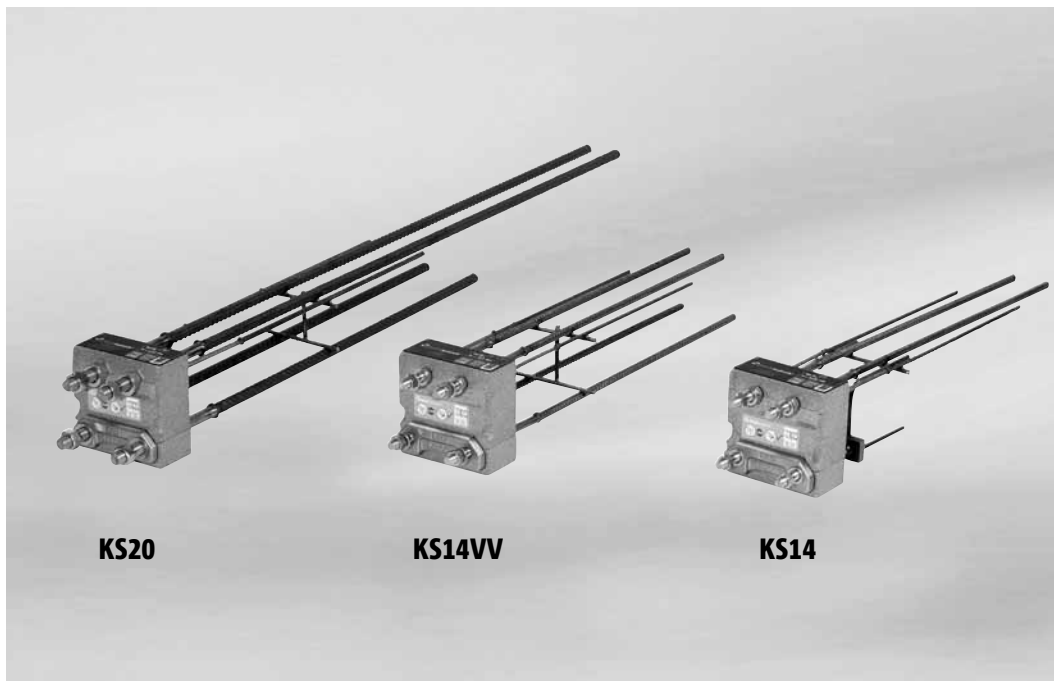

Schöck Isokorb® type KS

KS

Contents	Page
Connection layouts	140 - 141
Dimensions	142 - 143
Capacity table	144
Notes	145
Calculation example/Notes	146
Design considerations: Minimum distances – Steel member sizes	147
Lap splice reinforcement	148
Views/On-site end plates	149
Installation situation with on-site additional reinforcement	150
Important information	151
Method statement	152 - 157
Check list	158

Reinforced concrete-to-steel

Schöck Isokorb® type KS

Connection layouts

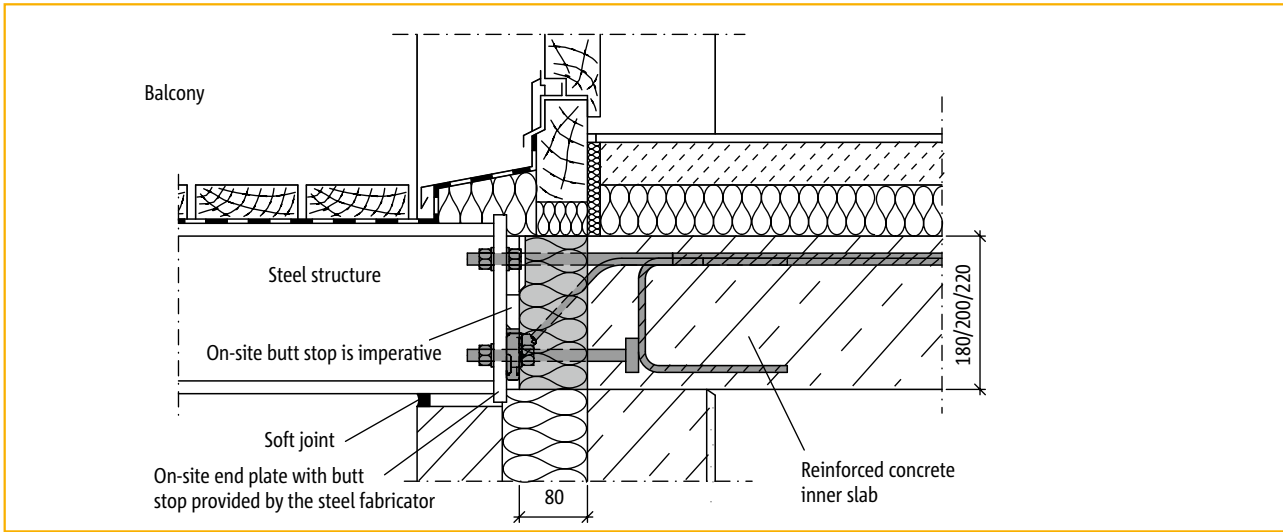

Connection with Schöck Isokorb® type KS 14 in a door area, cavity wall

KS

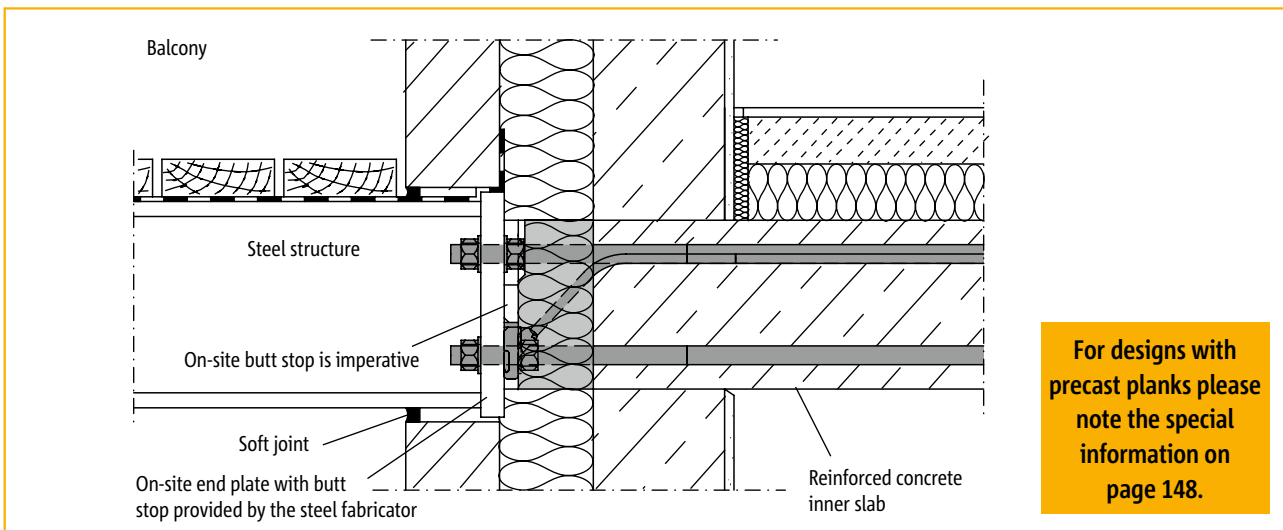

Connection with Schöck Isokorb® type KS 20 in a wall area, cavity wall

For designs with precast planks please note the special information on page 148.

Reinforced concrete-to-steel

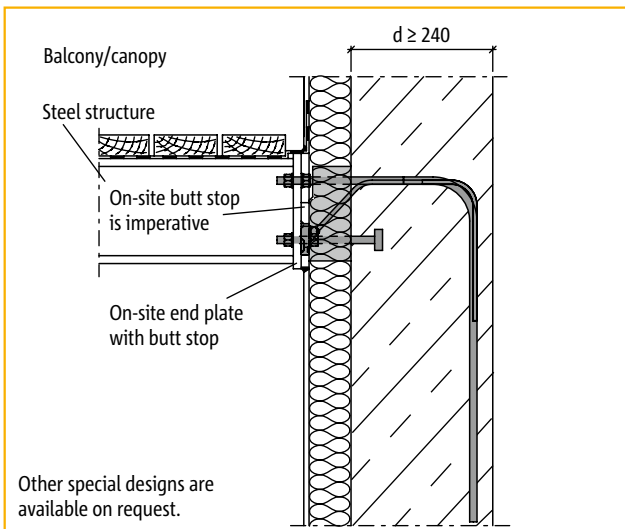

Connection with Schöck Isokorb® type KS 14 in a wall area without adjacent inner slab - special design

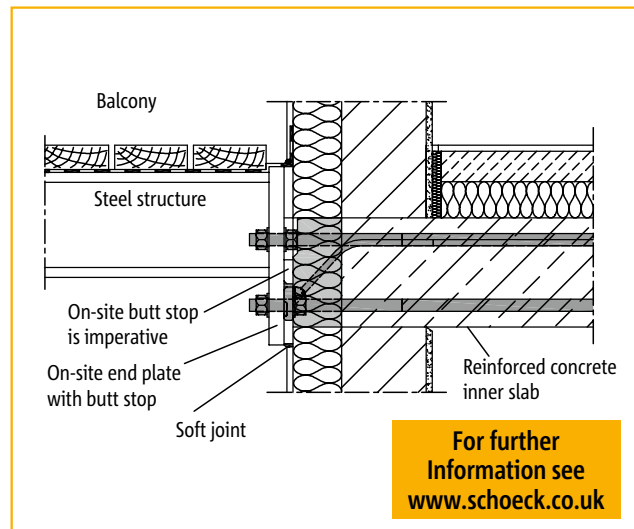

For further information see www.schoeck.co.uk

Raised connection detail for wheelchair access

Schöck Isokorb® type KS

Connection layouts

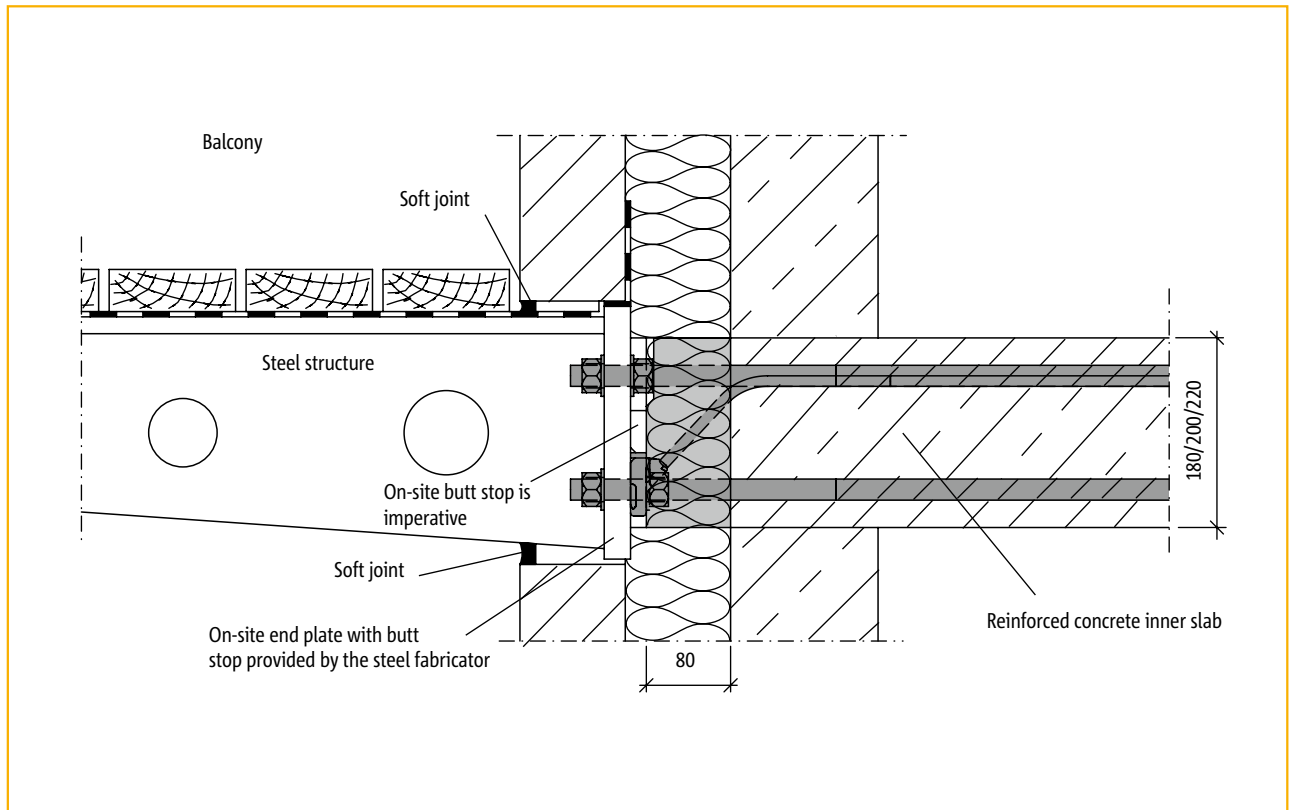

Side view: Connection with Schöck Isokorb® type KS 20, cavity wall

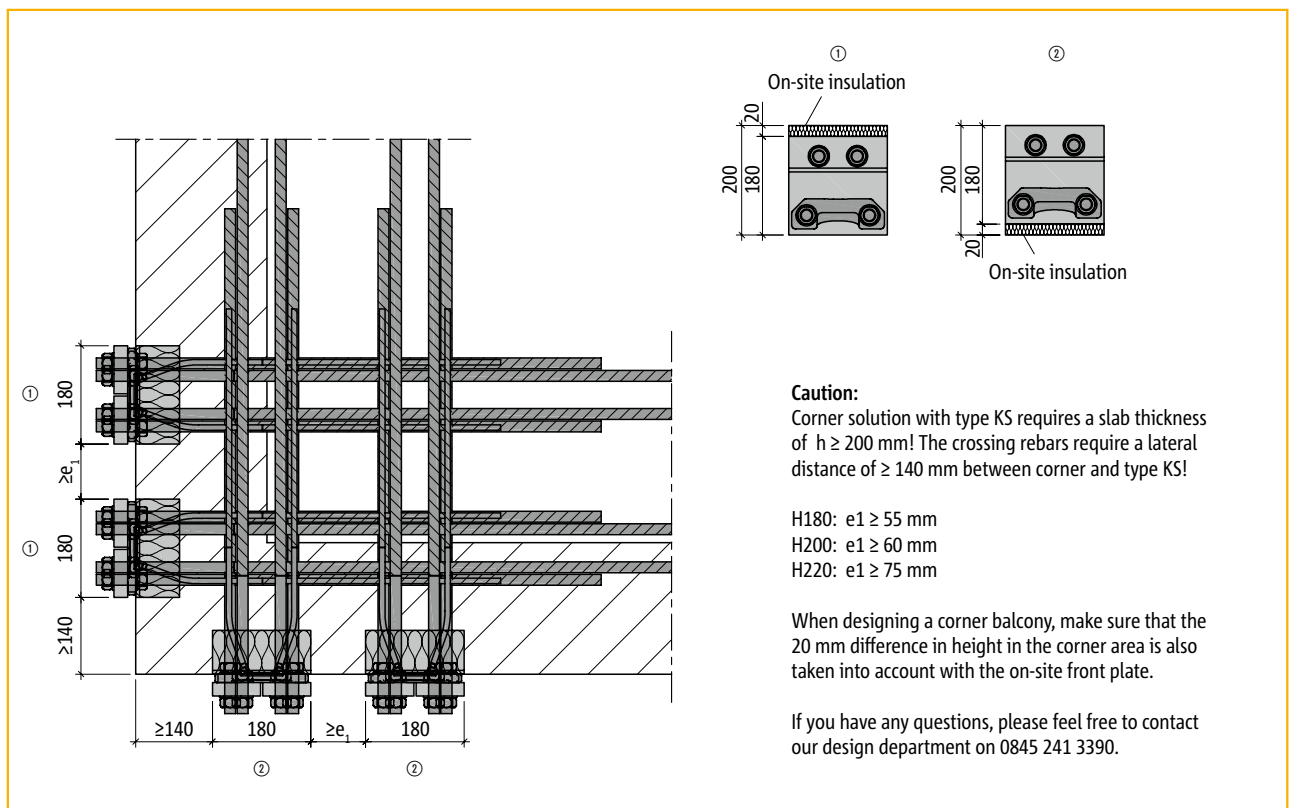

Plan view: Connection with Schöck Isokorb® type KS 20 in a corner area

KS

Reinforced concrete-to-steel

Caution:

Corner solution with type KS requires a slab thickness of $h \geq 200$ mm! The crossing rebars require a lateral distance of ≥ 140 mm between corner and type KS!

- H180: $e_1 \geq 55$ mm
- H200: $e_1 \geq 60$ mm
- H220: $e_1 \geq 75$ mm

When designing a corner balcony, make sure that the 20 mm difference in height in the corner area is also taken into account with the on-site front plate.

If you have any questions, please feel free to contact our design department on 0845 241 3390.

Schöck Isokorb® type KS

Dimensions

KS14

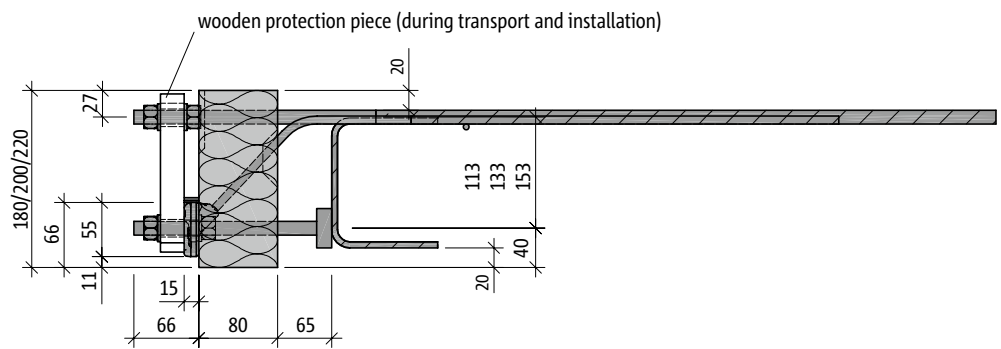

Side view: Schöck Isokorb® type KS14

KS14

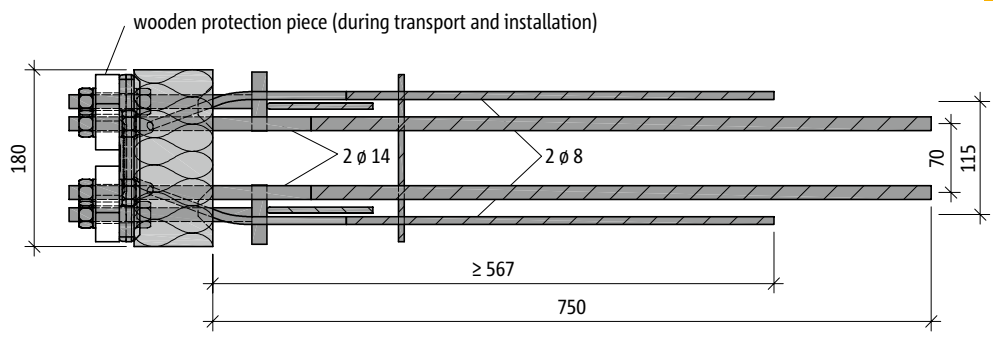

Plan view: Schöck Isokorb® type KS14

KS14-VV

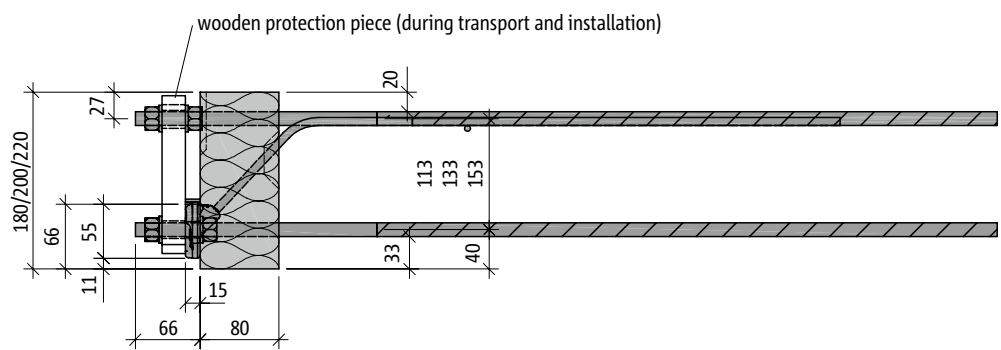

Side view: Schöck Isokorb® type KS14-VV

KS14-VV

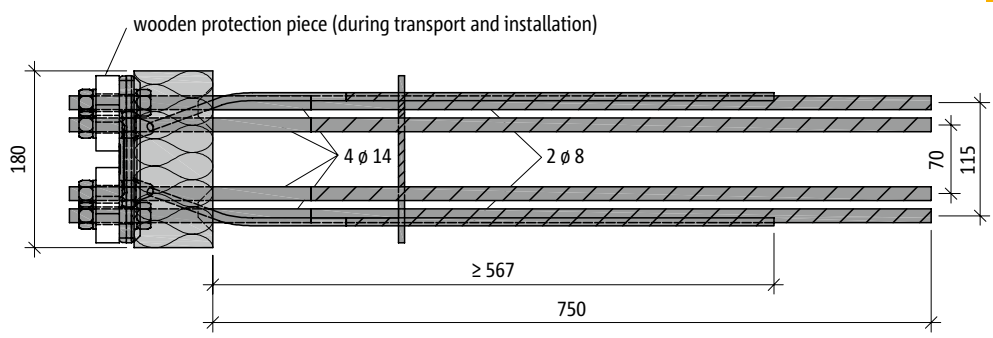

Plan view: Schöck Isokorb® type KS14-VV

KS

Reinforced concrete-to-steel

Schöck Isokorb® type KS

Dimensions

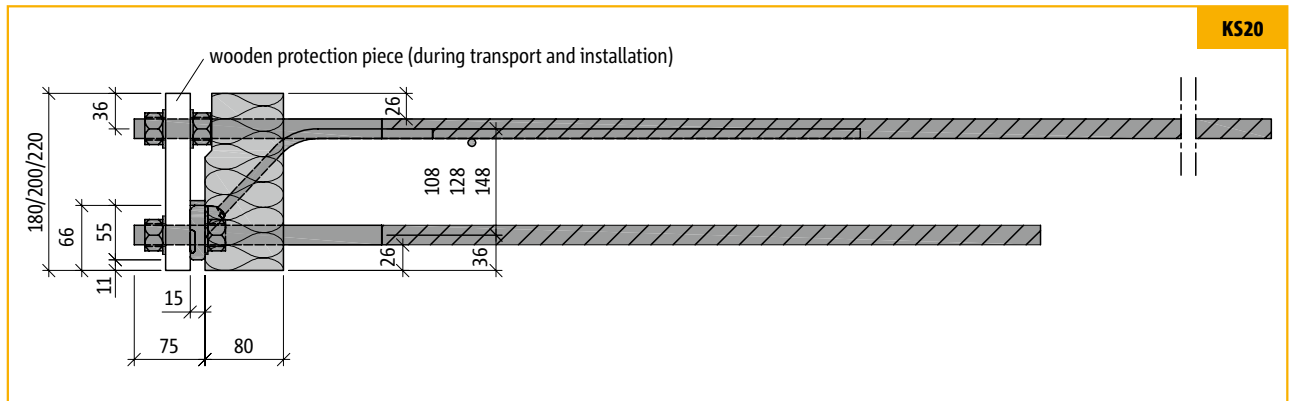

Side view: Schöck Isokorb® type KS20

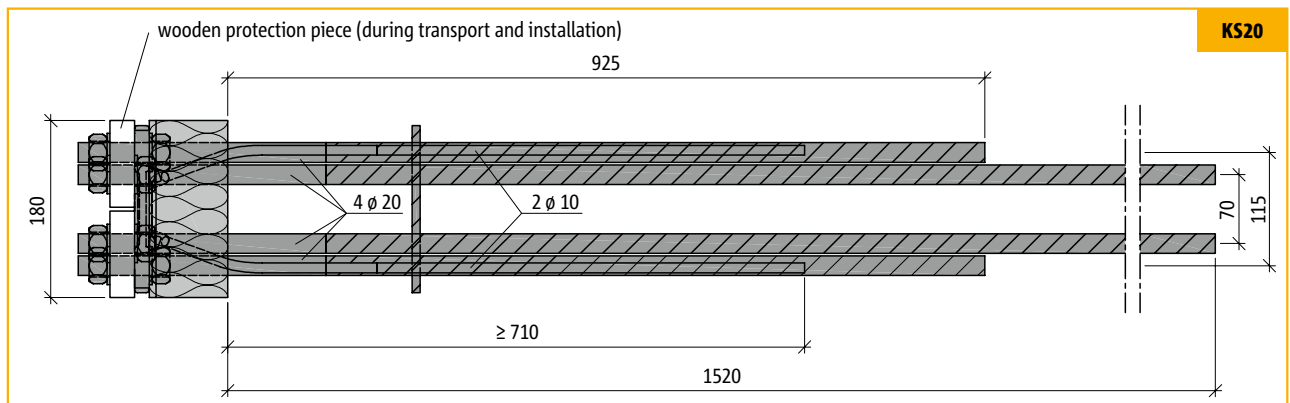

Plan view: Schöck Isokorb® type KS20

KS

Reinforced concrete-to-steel

Schöck Isokorb® type KS

Capacity table

The member forces are taken in relation to the rear edge of the front plate.

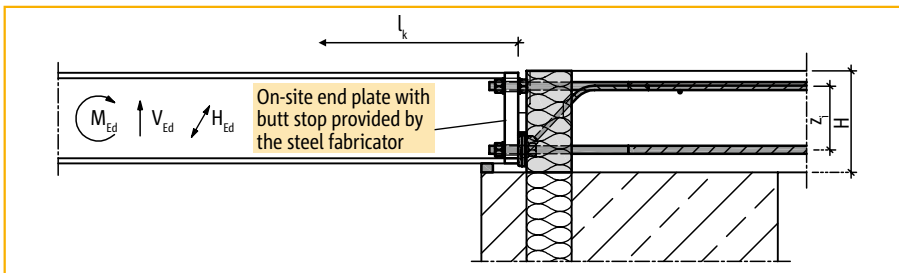
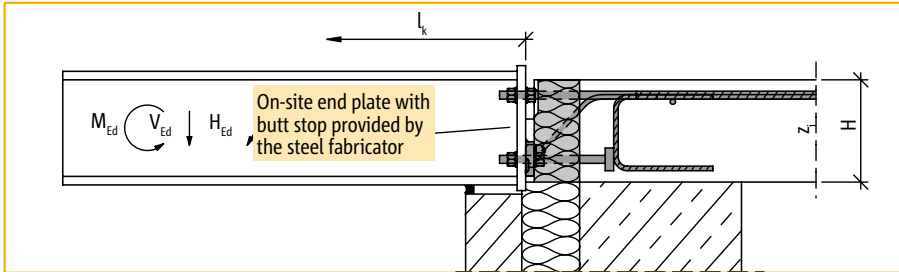

KS

► Check list on page 158 is to be observed!

Reinforced concrete-to-steel

Schöck Isokorb® type				KS14-V8	KS14-V10	KS14-VV	KS20-V10	KS20-V12			
Design values for concrete grade \geq C25/30				Moment capacity M_{Rd} [kNm]							
Height of Isokorb® H [mm]	180	Internal lever arm z_i [mm] (KS14 / KS20)	113 / 108	-10.1	-8.9	-10.1 +9.0	-22.1 +15.7	-20.6 +15.7			
	200		133 / 128	-11.9	-10.4	-12.1 +10.6	-26.2 +18.6	-24.4 +18.6			
	220		153 / 148	-13.7	-12.0	-14.0 +12.2	-30.3 +21.5	-28.2 +21.5			
Height of Isokorb® H [mm]				Shear force capacity V_{Rd} [kN] ¹⁾							
				180 - 220			+18.0	+30.0	+18.0 -12.0	+30.0 -12.0	+45.0 -12.0
				Horizontal shear force capacity H_{Rd} [kN] ²⁾							
				180 - 220			\pm 2.5	\pm 4.0	\pm 2.5	\pm 4.0	\pm 6.5
				Deflection factor $\tan \alpha$ [%]							
				180			0.8	0.7	1.2	1.5	1.5
				200			0.7	0.6	1.0	1.3	1.2
				220			0.6	0.5	0.9	1.1	1.1
				Torsional spring strength C [kNm/rad]							
				180			1300	1300	800	1500	1400
200			1700	1700	1200	2000	2000				
220			2300	2400	1500	2800	2500				
Max. expansion joint spacing [m]											
180 - 220			5.70			3.50					

¹⁾ If absorption of a greater shear force is necessary, please contact our design department under 0845 241 3390.

²⁾ In order to absorb the present horizontal force (H_{Ed}) parallel to the outside wall, a minimum shear force of $2.9 \times H_{Ed}$ must be ensured.

Schöck Isokorb® type KS

Notes

Notes regarding uplift loads

For uplift loads the KS14 VV and the KS20 V10/12 should be used. For the correct transfer of the shear loads (shear in the upwards direction). These shear loads are transferred through the direct contact between the bolts of the Schöck Isokorb® type KS and the end plate. There must be no play in the connection.

Notes for the design of the construction at lifting loads.

1. The on-site end plate must have round holes (no slots) in its lower region (see page 149).
As a consequence, vertical adjustment is no longer possible.
2. In many cases it is sufficient to assign the lifting forces to just two of several elements per connection layout.

Deflection

The deflection values shown in the calculation tables result solely from the deformation of the Schöck Isokorb® element. The final precamber of the balcony construction results from the calculation according to BS 8500, or according to EC 2, plus the precamber due to the Schöck Isokorb®.

The precamber of the balcony construction to be specified by the engineer in charge.

Deflection due to Schöck Isokorb®:

$$p \text{ [mm]} = \text{Table value} \times l_k \times 10 \times M_{Ed} / M_{Rd}$$

l_k length of projection [m]

M_{Ed} Bending Moment for calculation of the deflection; determined by the structural engineer; according to EC2: $M_{Ed,perm}$ based on DL + 0.3 LL [kNm]

M_{Rd} maximum rated moment of the Schöck Isokorb®

Note:

The above values give an approximation only. Depending on the specific design layout and construction, other values may need to be used.

Expansion joint spacing

The determination of the permissible expansion joint spacing (= distances between expansion joints) is based on a balcony slab made of reinforced concrete, in case of it is fixed to the cantilevered steel profiles.

If constructive measures are implemented to allow movement between the balcony slab and the individual steel profiles, then only the distances between the fixed connections are significant.

Installation tolerances

Due to its design, the Schöck Isokorb® type KS **only allows compensation of tolerances in a vertical direction**. The vertical tolerance is +10 mm; the horizontal tolerance is ± 0 mm. We recommend the use of an on-site template to ensure the correct position. The planning engineer should inform the **concrete frame contractor** about these details in the implementation plans.

In order to ensure that the shell and the finishings join together properly without the need for modification or reworking, the **site management** must check that the tolerances are met and **take this into account in the design of the steel structure**. Dimension tolerances must be taken into account.

Schöck Isokorb® type KS

Calculation example/Notes

Dimensions:

Length of projection: $l_k = 1.75$ m
 Balcony width: $b = 4.50$ m
 Inner slab slab thickness: $h = 200$ mm
 Height of Isokorb®: $H = 200$ mm
 Chosen axis separation: $a = 0.70$ m

Load assumptions:

Self weight with light coating: $g_b = 0.6$ kN/m²
 Live load: $q = 4.0$ kN/m²
 Self weight of railing: $F_G = 0.75$ kN/m
 Horizontal load on the railing at beam height 1.0 m: $H_G = 0.5$ kN/m

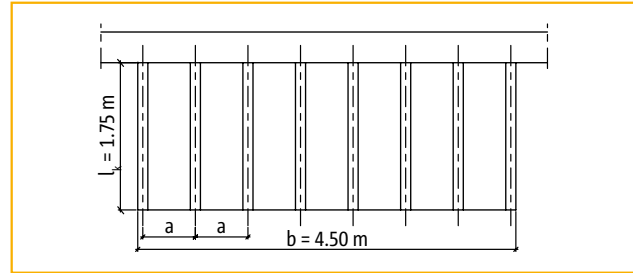
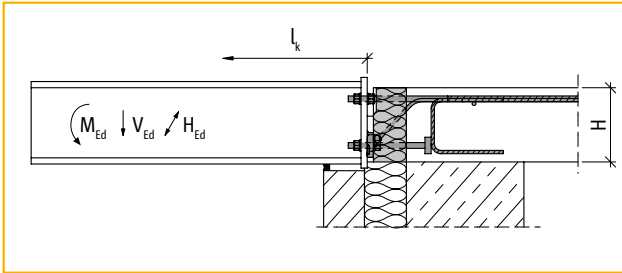

KS

$$M_{Ed} = -[(\gamma_G \times g_b + \gamma_Q \times q) \times l_k^2 / 2 \times a + \gamma_G \times F_G \times a \times l_k + \gamma_Q \times \psi_0 \times H_G \times 1.0 \times a] \text{ [kNm]}$$

$$M_{Ed} = -[(1.35 \times 0.6 + 1.5 \times 4.0) \times 1.75^2 \times 0.7 / 2 + 1.35 \times 0.75 \times 0.7 \times 1.75 + 1.5 \times 0.7 \times 0.5 \times 1.0 \times 0.7] \text{ [kNm]}$$

$$M_{Ed} = -8.9 \text{ kNm}$$

$$V_{Ed} = [(\gamma_G \times g_b + \gamma_Q \times q) \times a \times l_k] + \gamma_G \times F_G \times a$$

$$V_{Ed} = [(1.35 \times 0.6 + 1.5 \times 4.0) \times 0.70 \times 1.75] + 1.35 \times 0.75 \times 0.7$$

$$V_{Ed} = +9.1 \text{ kN}$$

Required number of connections: $n = (4.50/0.7) + 1 = 7.4 = 8$ connections

Axis separation between steel members: $((4.50 - 0.18)/7) = 0.617$ m

Choice: **8 × Schöck Isokorb® type KS14-V8-H200**

$$M_{Rd} = -11.9 \text{ kNm} > M_{Ed} = -8.9 \text{ kNm}$$

$$V_{Rd} = +18.0 \text{ kN} > V_{Ed} = +9.1 \text{ kN}$$

Deflection

Prospected deformation in the serviceability limit state (SLS) according to EC2 (DL+0.3LL):

$$M_{Ed,perm} = -[(g_b + \psi_{2,i} \times q) \times l^2 / 2 \times a + F_g \times a \times l_k + \psi_{2,i} \times H_G \times 1.0]$$

$$M_{Ed,perm} = -[(0.6 + 0.3 \times 0.4) \times 1.75^2 / 2 \times 0.7 + 0.75 \times 0.7 \times 1.75 + 0.3 \times 0.5 \times 1.0 \times 0.7]$$

$$M_{Ed,perm} = -3.0 \text{ kNm}$$

$$\text{Deflection } p = 0.7 \times 1.75 \times 10 \times -3.0 / -11.9 = 3.0 \text{ mm}$$

Notes

- ▶ The range of potential applications for Schöck Isokorb® type KS elements covers inner slab and balcony structures with predominantly static and evenly distributed live loads.
- ▶ Static proof must be presented for the adjacent components on both sides of the Schöck Isokorb® type KS.
- ▶ The upper and lower reinforcement of the inner slab should be located as close as possible to the thermal insulation layer, taking into account the required concrete cover.
- ▶ The nominal dimension c_{nom} for the upper concrete cover is 20 mm in the inside area.

Reinforced concrete-to-steel

Schöck Isokorb® type KS

Design considerations: Minimum distances – Steel member sizes

Centre and edge spacing

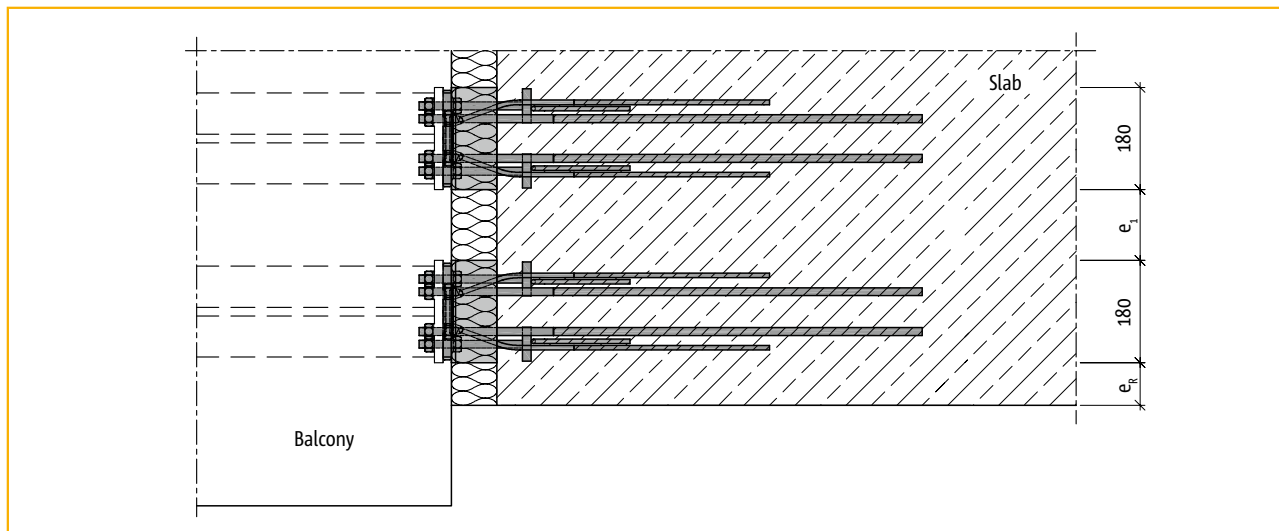

Schöck Isokorb® type KS centre and edge spacing

Schöck Isokorb® type		KS	
Element and edge distance [mm]		e_R	e_1
Height of Isokorb® H [mm]	180	≥ 75	≥ 55
	200	≥ 80	≥ 60
	220	≥ 90	≥ 75

In cases where it is not possible to respect these conditions, the load-bearing capacity of the elements must be reduced. Please contact our design department, Tel. 07223 967-567.

Design guidelines for steel beams

For the design of the steel work, we suggest using the minimum sizes given in the table below.

Schöck Isokorb® type		KS14 and KS14-VV		KS20	
recommended minimum section sizes		a = 25 mm		a = 30 mm	
		UB	UC	UB	UC
Height of Isokorb® H [mm]	180	203	203	203	203
	200	203	254	254	254
	220	254	254	254	254

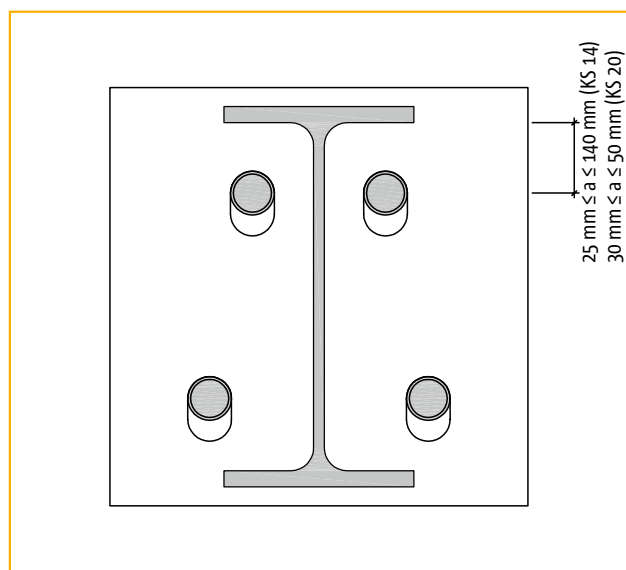

Front view of end plate: Schöck Isokorb® type KS 20 with an IPE200

KS

Reinforced concrete-to-steel

Schöck Isokorb® type KS

Lap splice reinforcement

Schöck Isokorb Types KS tensile reinforcement is designed to provide sufficient length for the design of a lap splice with “on site” reinforcement. Therefore Schöck recommends to lap 2no.T16 with the KS 14 and 2 no.T20 with the KS 20.

Schöck Isokorb® type KS 14

Lap splice: Design lap splice with 2 No. T16 rebars according to BS, L according to structural engineer, item ① (additional on-site reinforcement)

Transverse reinforcement: Non-structural transverse reinforcement according to BS

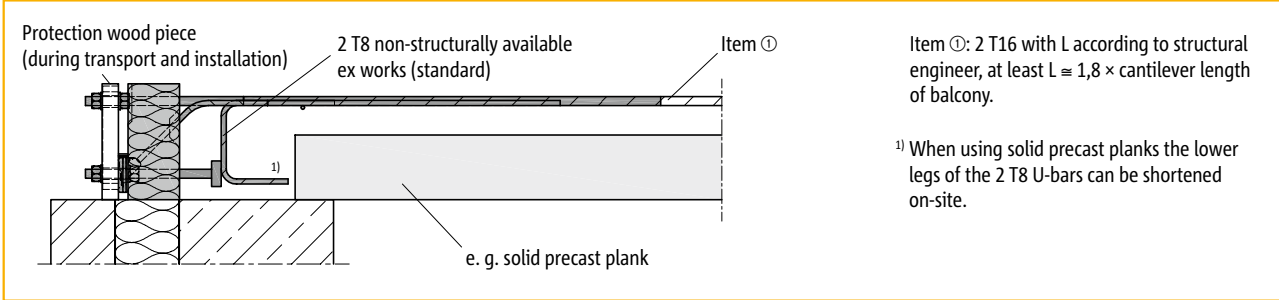

Item ①: 2 T16 with L according to structural engineer, at least $L \approx 1,8 \times$ cantilever length of balcony.

¹⁾ When using solid precast planks the lower legs of the 2 T8 U-bars can be shortened on-site.

Side view: Schöck Isokorb® type KS 14 for designs with precast floor slabs

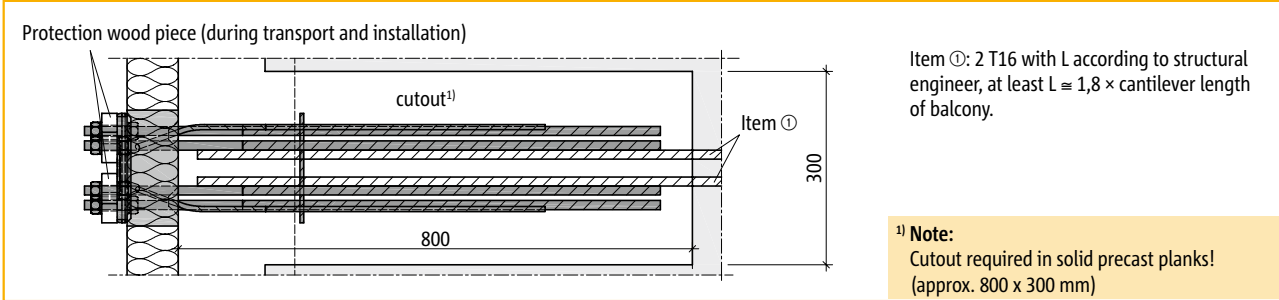

Item ①: 2 T16 with L according to structural engineer, at least $L \approx 1,8 \times$ cantilever length of balcony.

¹⁾ Note: Cutout required in solid precast planks! (approx. 800 x 300 mm)

Plan view: Schöck Isokorb® type KS 14-VV when used for lifting forces

Schöck Isokorb® type KS 20

Overlapping joint: Design lap splice with 4 T16 or with 2 T20 according to BS, L according to structural engineer, item ③ (additional on-site reinforcement)

Transverse reinforcement: External transverse reinforcement links (see illustration), item ① and item ②

► Please check EC2, clause 8.7.4 “Transverse reinforcement (links) in the lap zone”

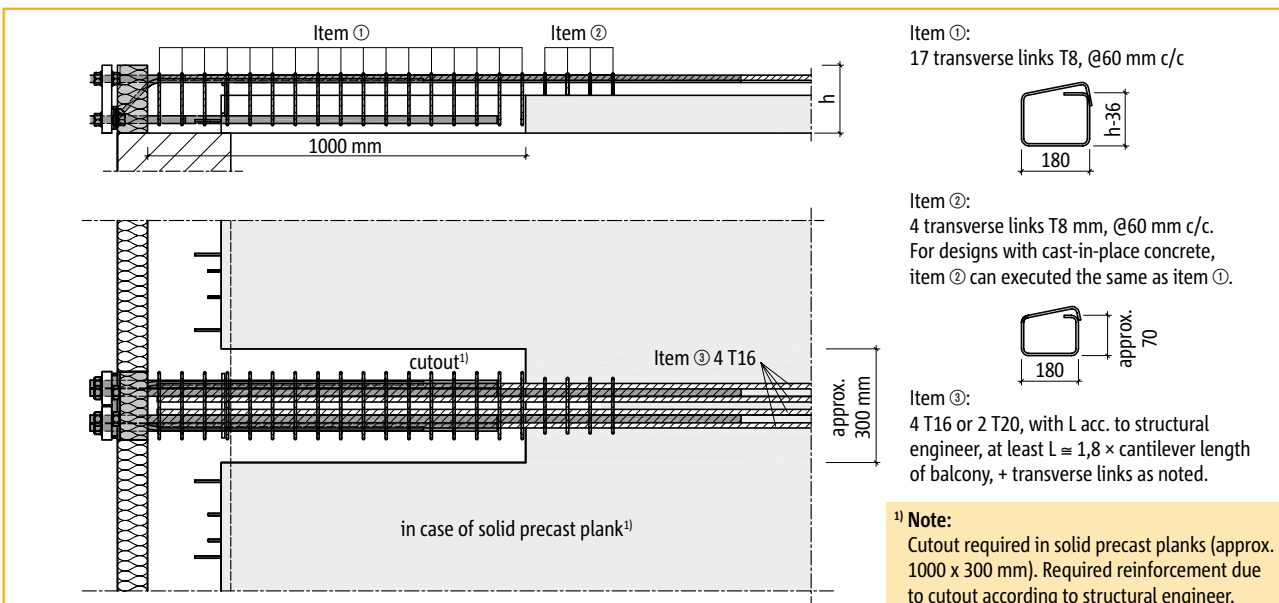

Item ①:
17 transverse links T8, @60 mm c/c

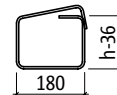

Item ②:
4 transverse links T8 mm, @60 mm c/c.
For designs with cast-in-place concrete, item ② can be executed the same as item ①.

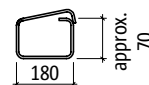

Item ③:
4 T16 or 2 T20, with L acc. to structural engineer, at least $L \approx 1,8 \times$ cantilever length of balcony, + transverse links as noted.

¹⁾ Note: Cutout required in solid precast planks (approx. 1000 x 300 mm). Required reinforcement due to cutout according to structural engineer.

On-site connection reinforcement for Schöck Isokorb® type KS 20

Schöck Isokorb® type KS

Views/On-site end plates

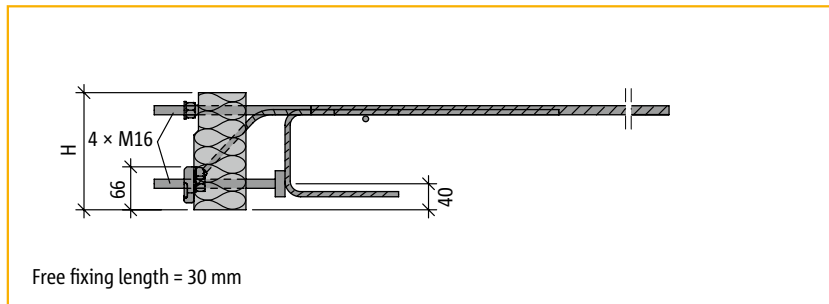

Side view: Schöck Isokorb® type KS 14

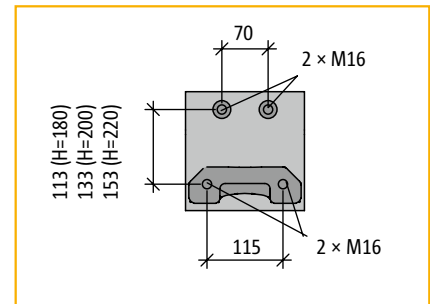

Front view: Schöck Isokorb® type KS 14

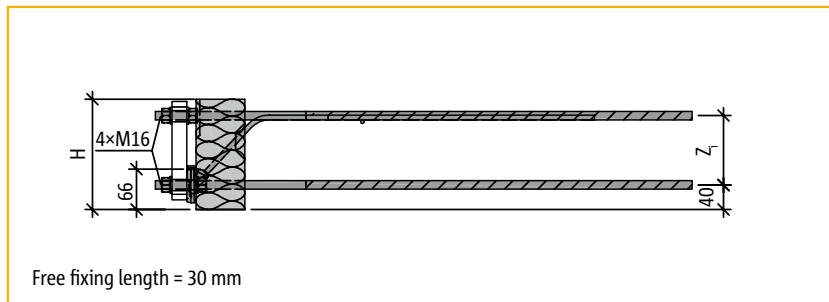

Side view: Schöck Isokorb® type KS 14 VV

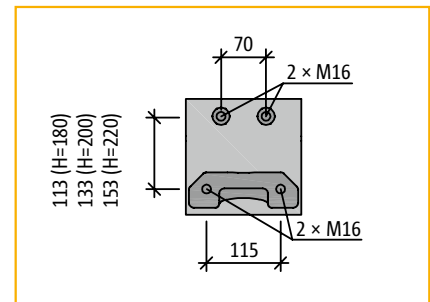

Front view: Schöck Isokorb® type KS 14 VV

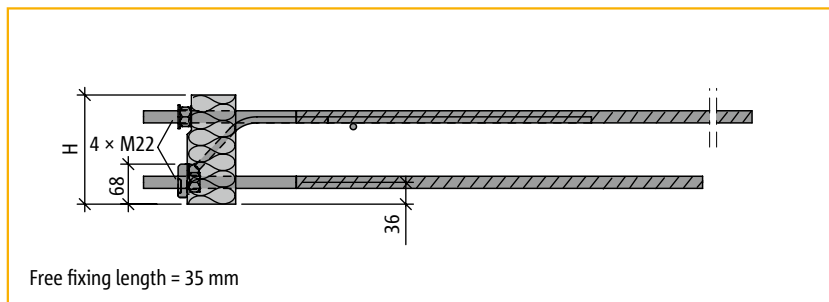

Side view: Schöck Isokorb® type KS 20

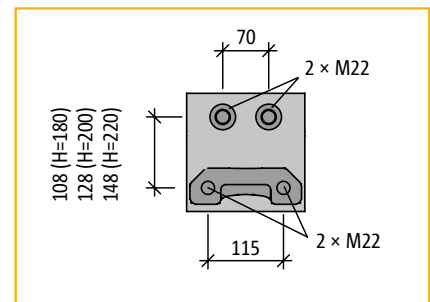

Front view: Schöck Isokorb® type KS 20

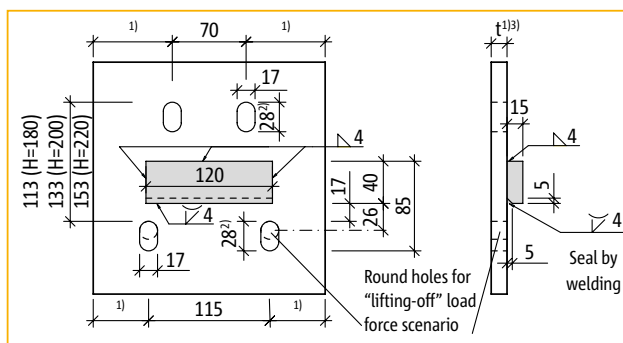

On-site end plate for Schöck Isokorb® type KS 14

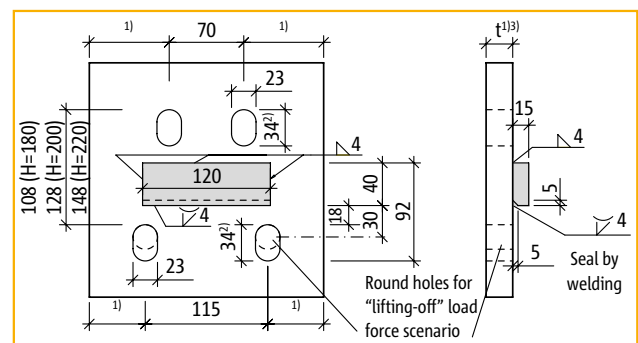

On-site end plate for Schöck Isokorb® type KS 20

Note

- ▶ **The butt stop is imperative in order to transfer shear forces – provided by the steel fabricator.**
- ▶ Choice of steel type according to the structural requirements. Anti-corrosion protection to be applied after welding.
- ▶ Steel construction: The tolerances of the internal structure must be checked in all cases.

¹⁾ According to the information provided by the structural design engineer.

²⁾ Hole size corresponds to a height adjustment of +10 mm. The scope for height adjustment can be increased by enlarging the hole size.

³⁾ Note the free fixing length.

Schöck Isokorb® type KS

Installation situation with on-site additional reinforcement

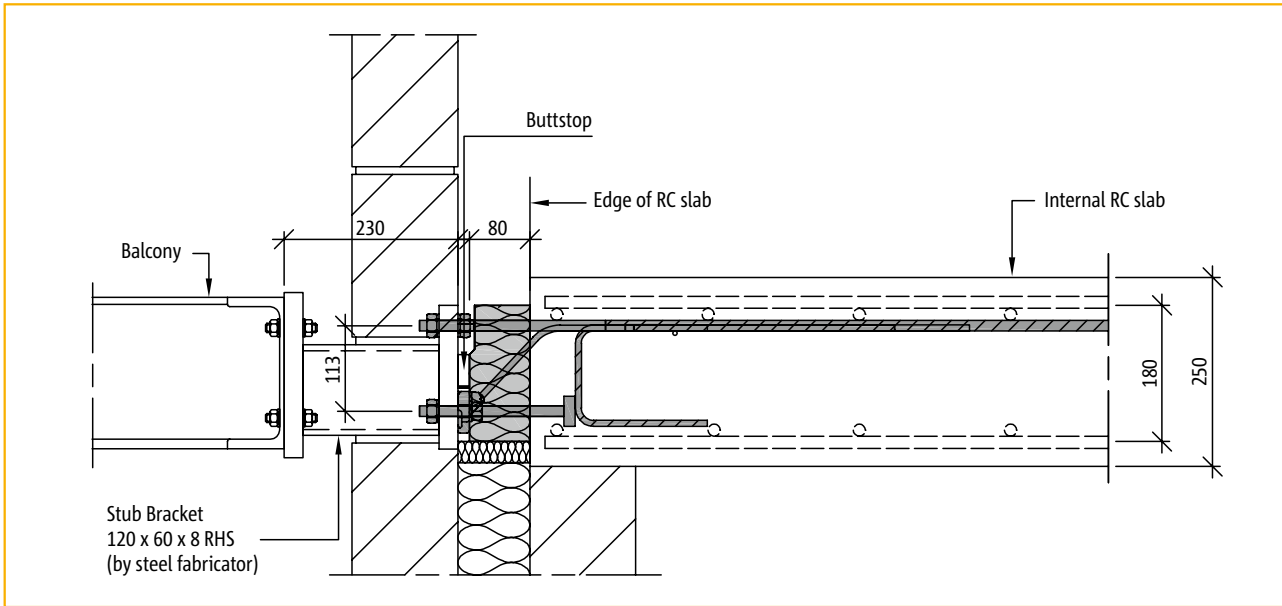

Section through Schöck Isokorb® type KS14-H180

KS

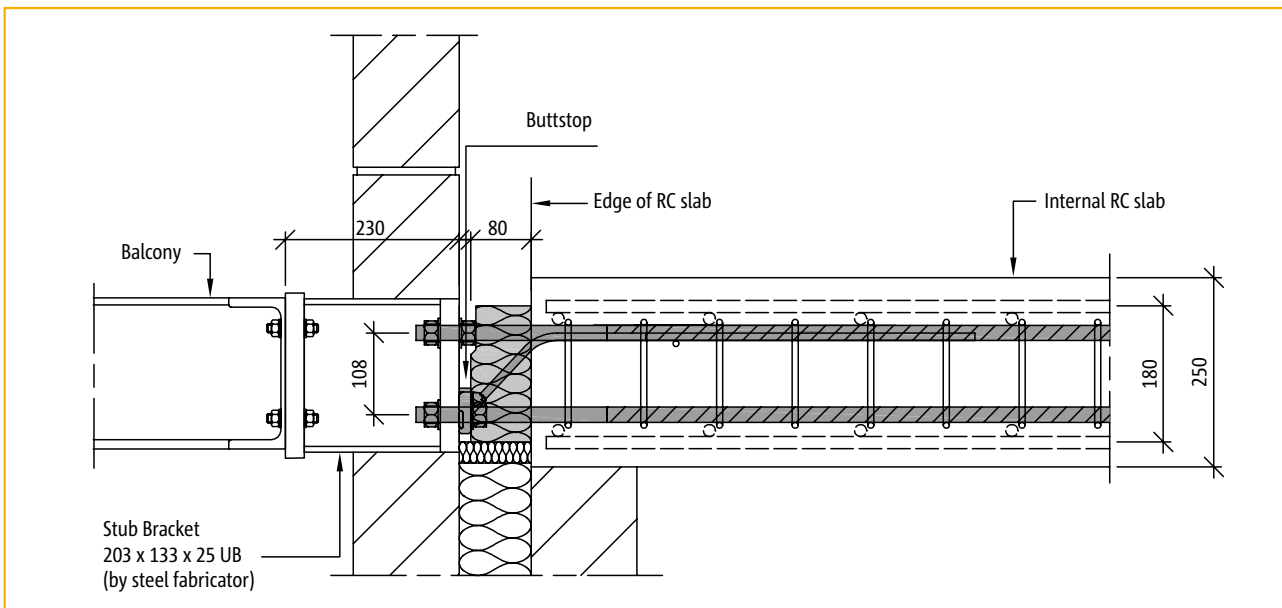

Section through Schöck Isokorb® type KS20-H180

Reinforced concrete-to-steel

Schöck Isokorb® type KS

Important information

A butt stop, welded to the on-site end plate, is imperative for transfer of shear forces to the Schöck Isokorb® type KS (or QS)

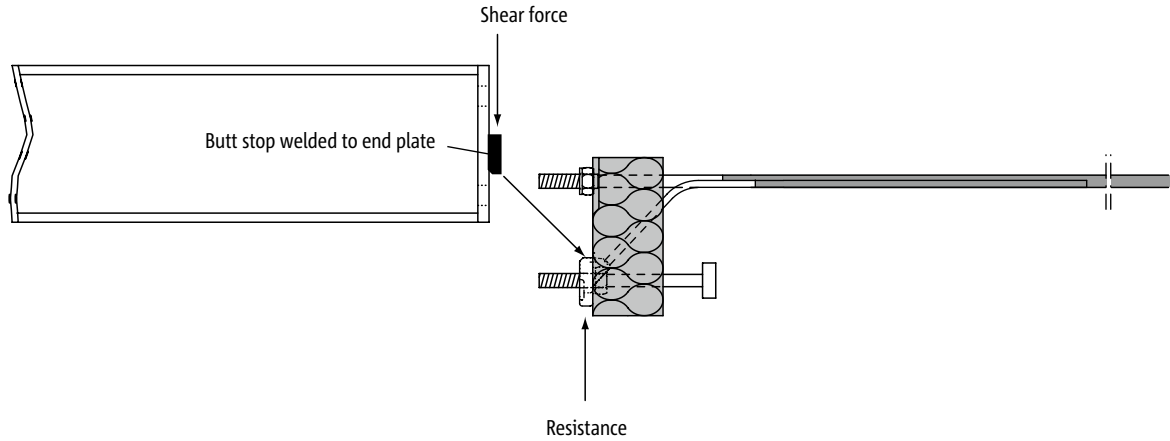

Side view: Imperative butt stop for the connection of steel fin to Schöck Isokorb®

The butt stop has to be provided by the steel fabricator

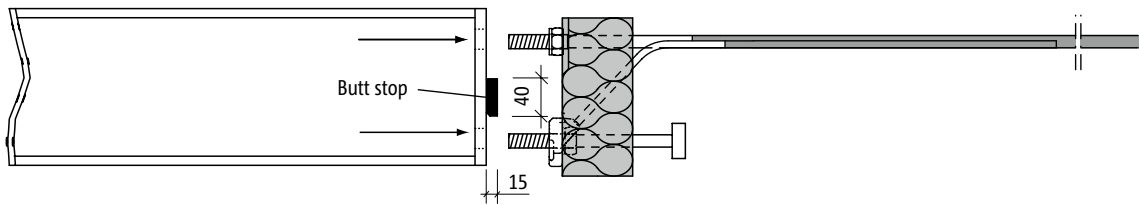

Side view: Mounting of steel beam to Schöck Isokorb®

After the installation of the cantilever beam with end plate and its butt stop, the butt stop transfers the shear forces to the type KS (or QS)

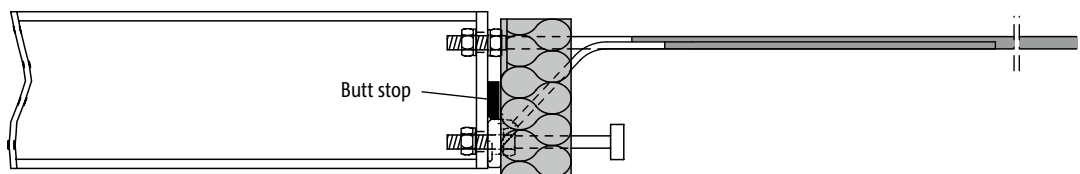

Side view: Once installed the butt stop transfers the shear forces

KS

Reinforced concrete-to-steel

Schöck Isokorb® type KS14

Method statement for concrete frame constructor

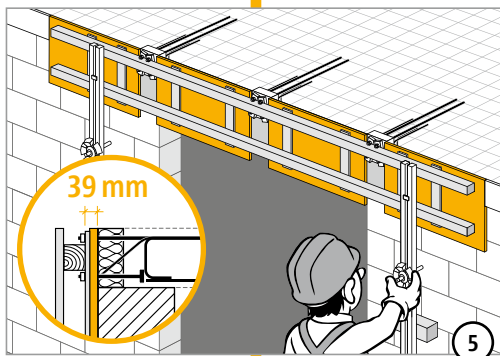
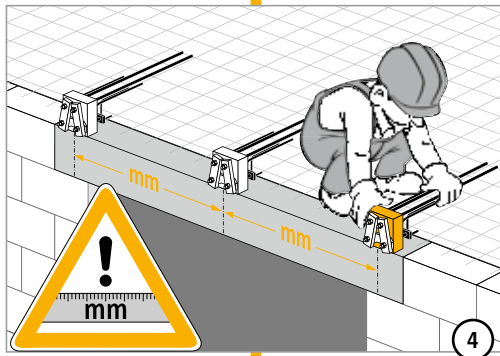
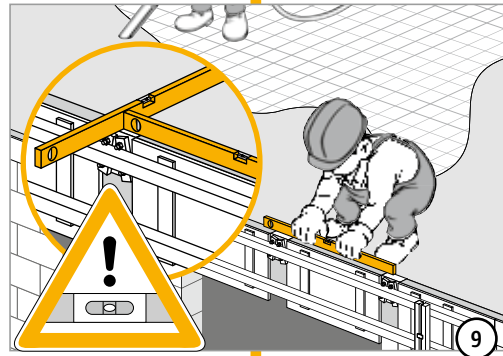
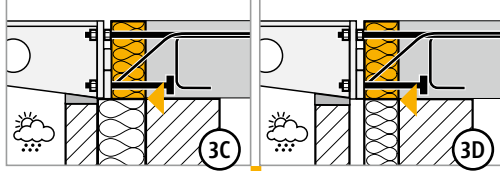
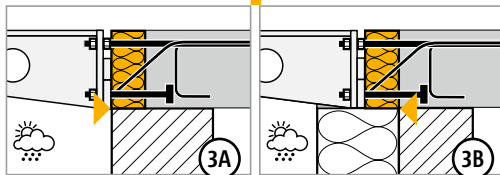
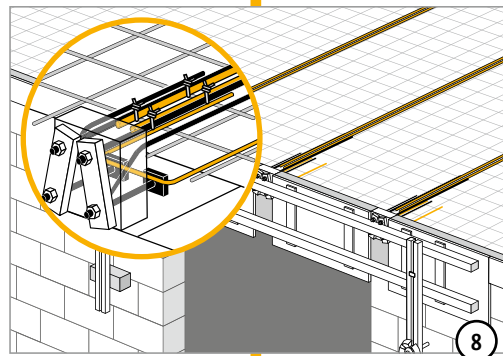
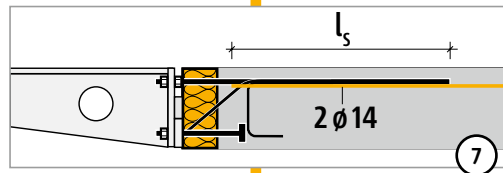
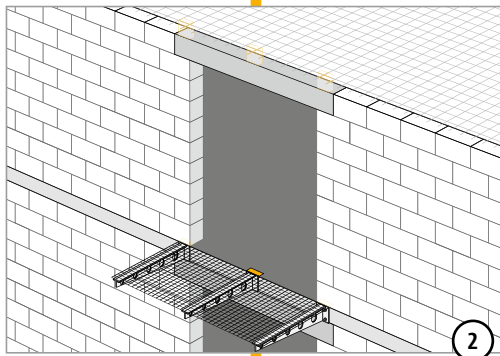
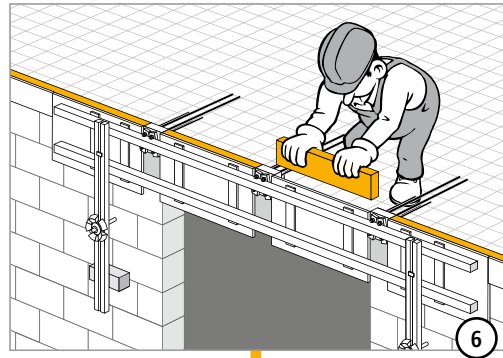
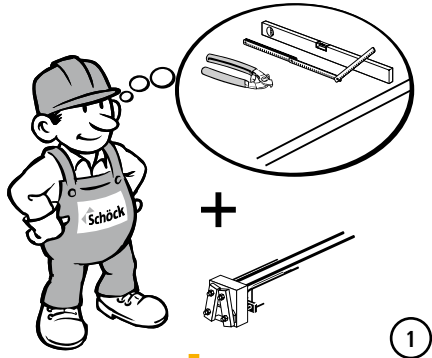

KS

Reinforced concrete-to-steel

Schöck Isokorb® type KS14

Method statement for steel fabricators

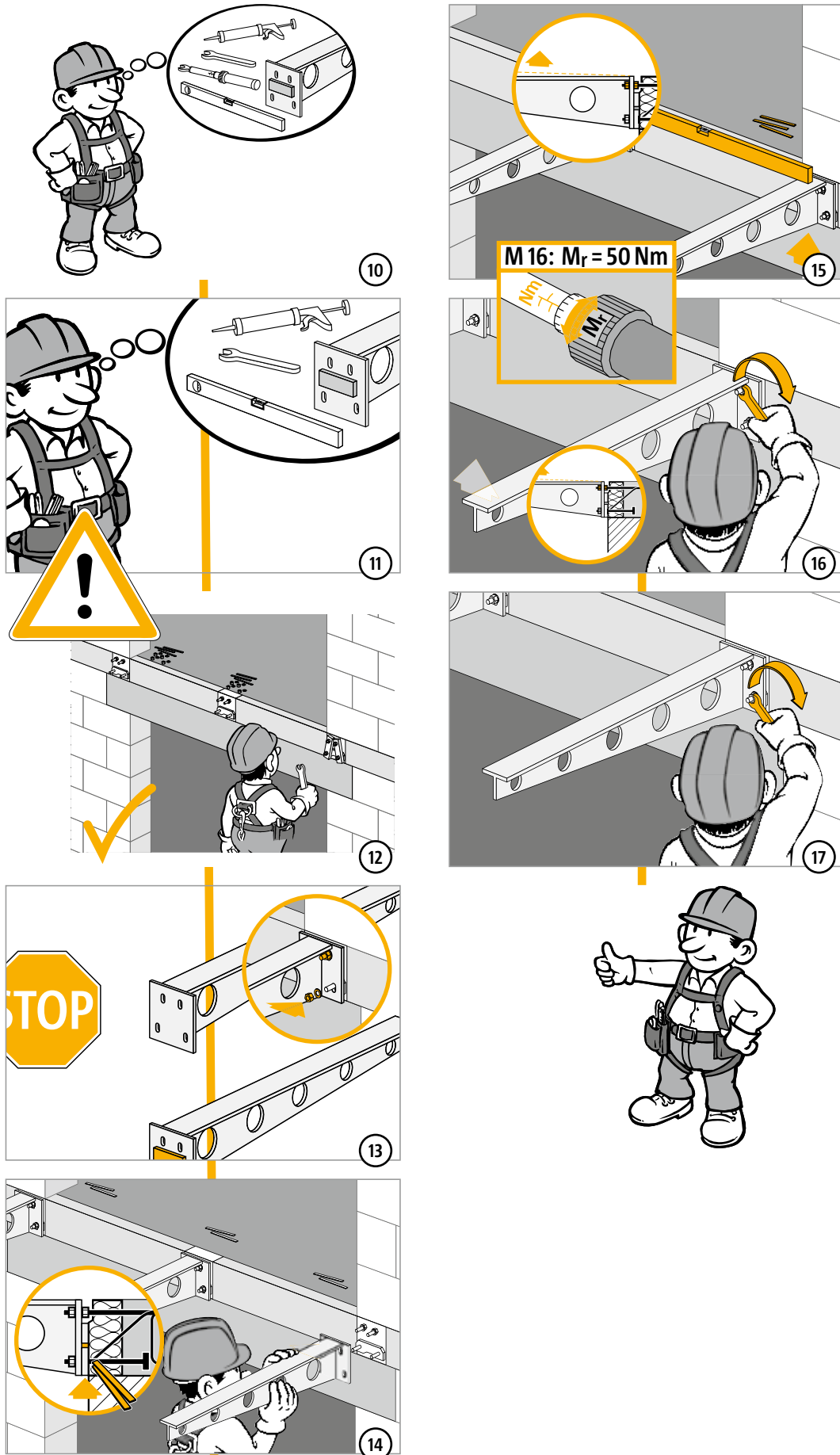

KS

Reinforced concrete-to-steel

Schöck Isokorb® type KS14-VV

Method statement for concrete frame constructor

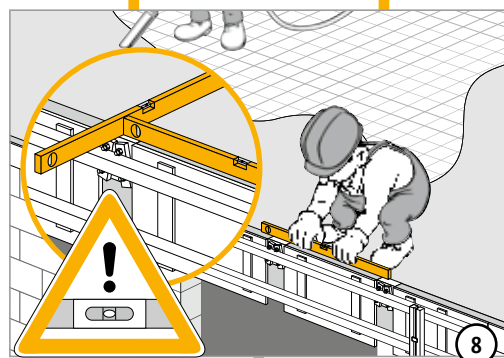
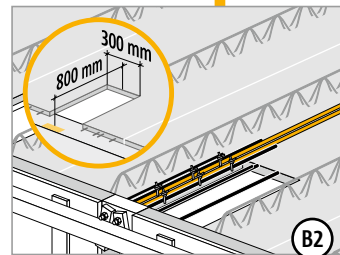
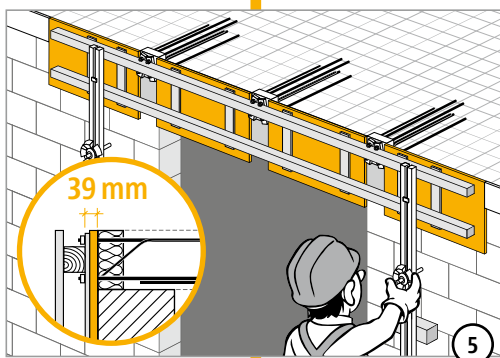
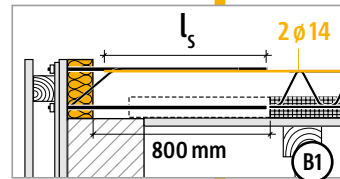
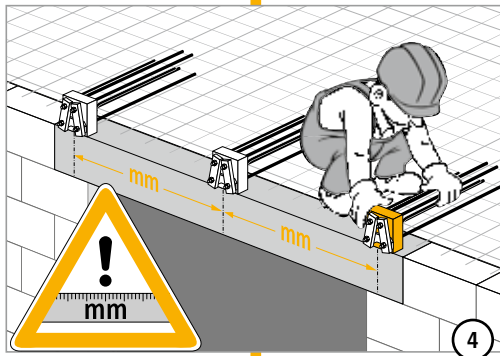
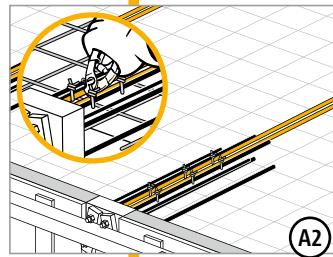
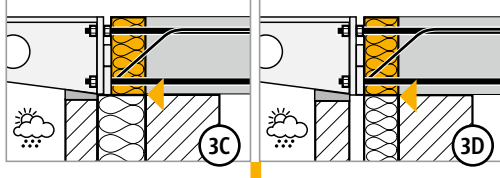
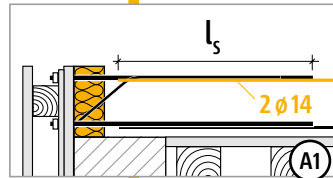
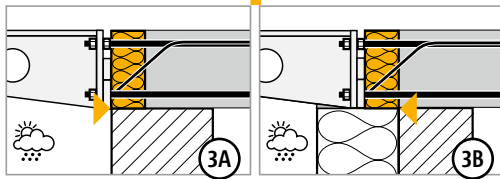
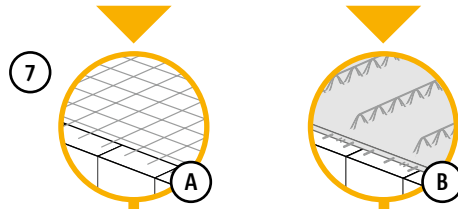
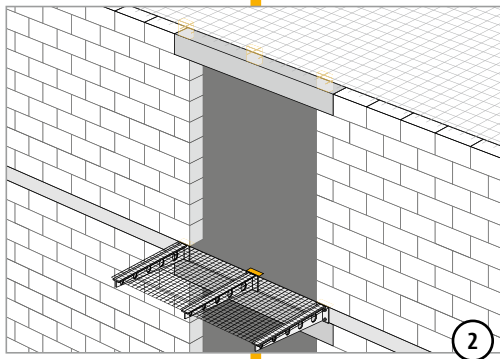
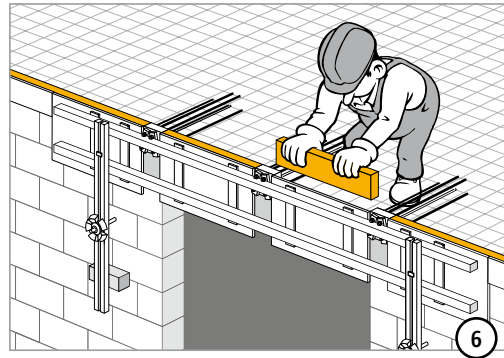
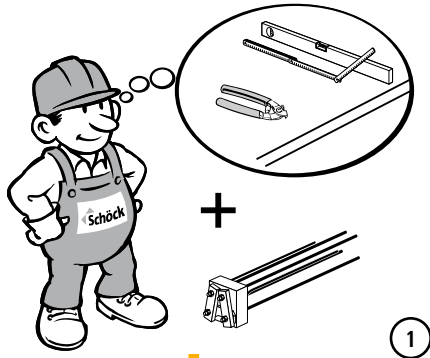

KS

Reinforced concrete-to-steel

Schöck Isokorb® type KS14-VV

Method statement for steel fabricators

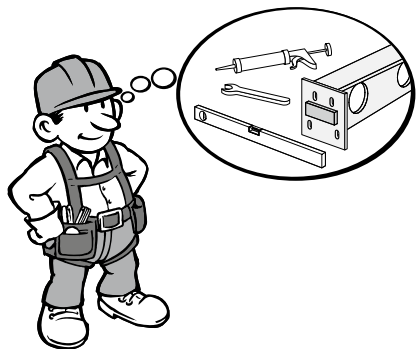

9



10

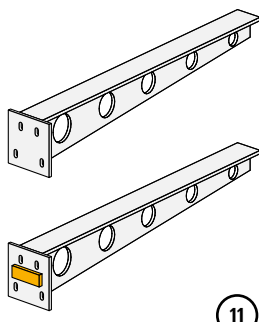

11

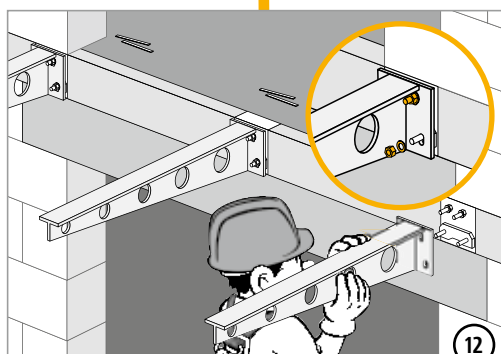

12

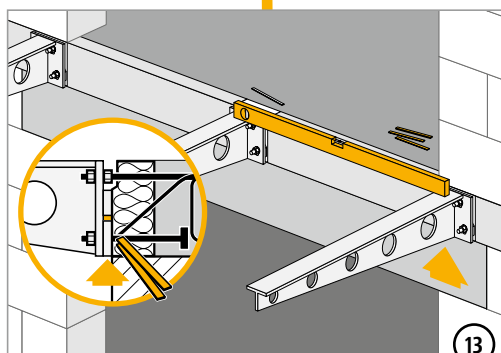

13

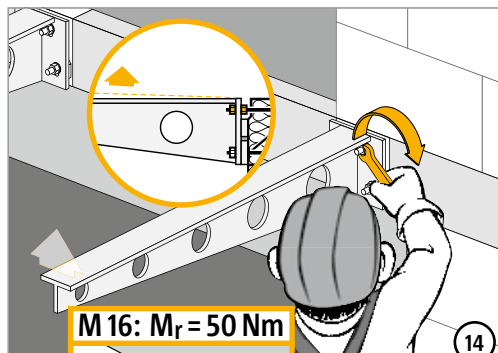

M 16: $M_r = 50 \text{ Nm}$

14

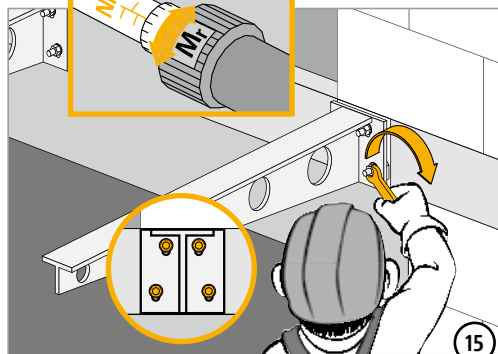

15

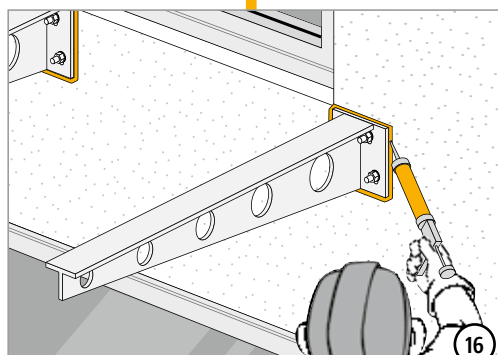

16



KS

Reinforced concrete-to-steel

Schöck Isokorb® type KS20

Method statement for concrete frame constructor

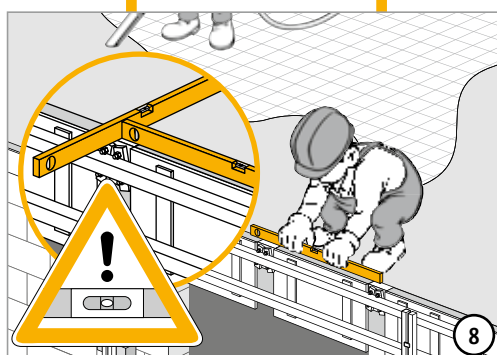
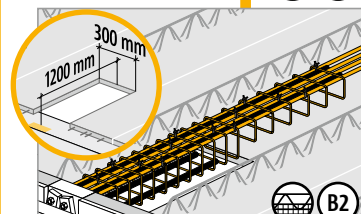
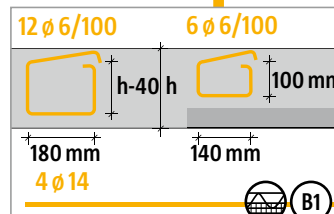
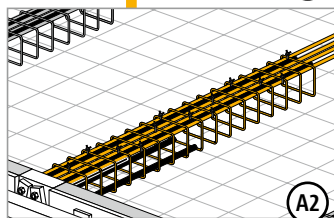
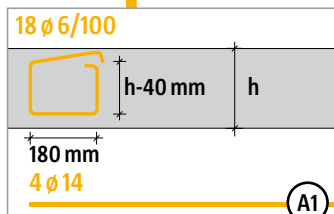
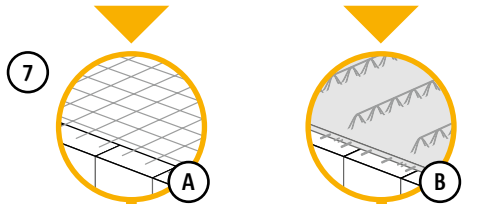
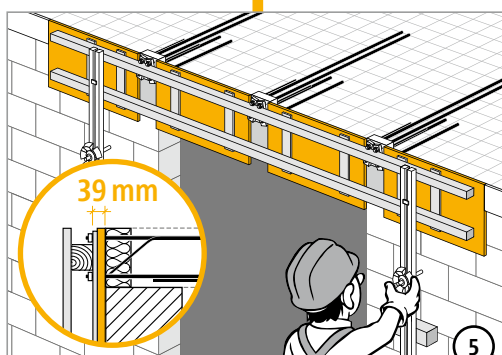
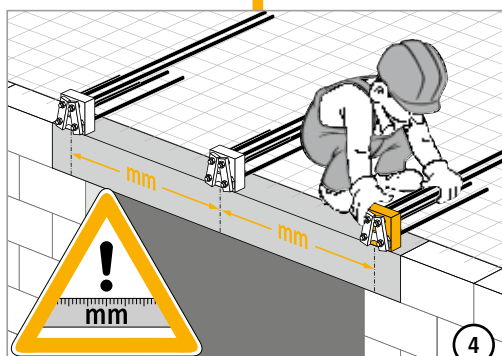
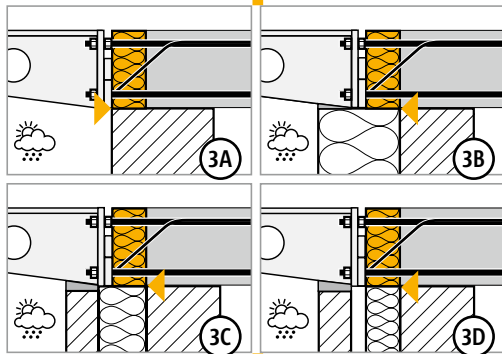
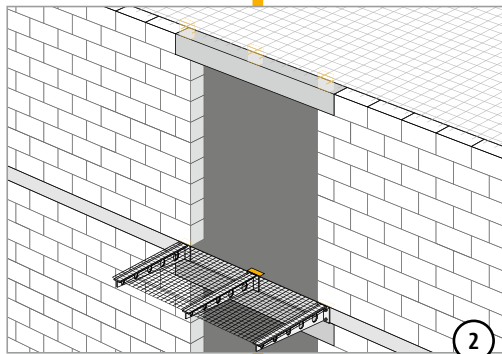
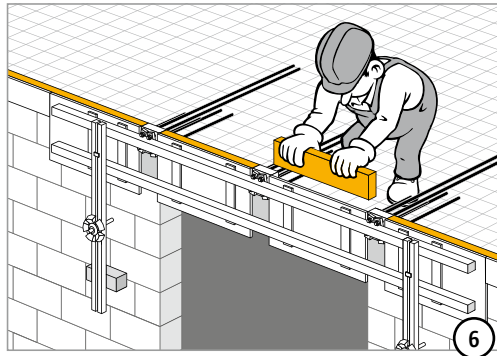
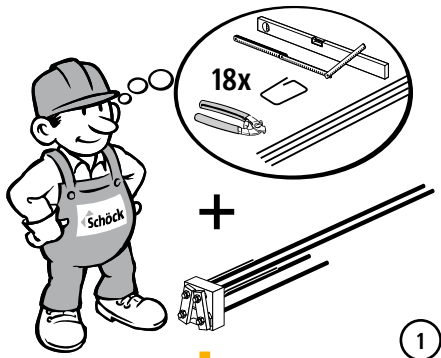

KS

Reinforced concrete-to-steel

Schöck Isokorb® type KS20

Method statement for steel fabricators

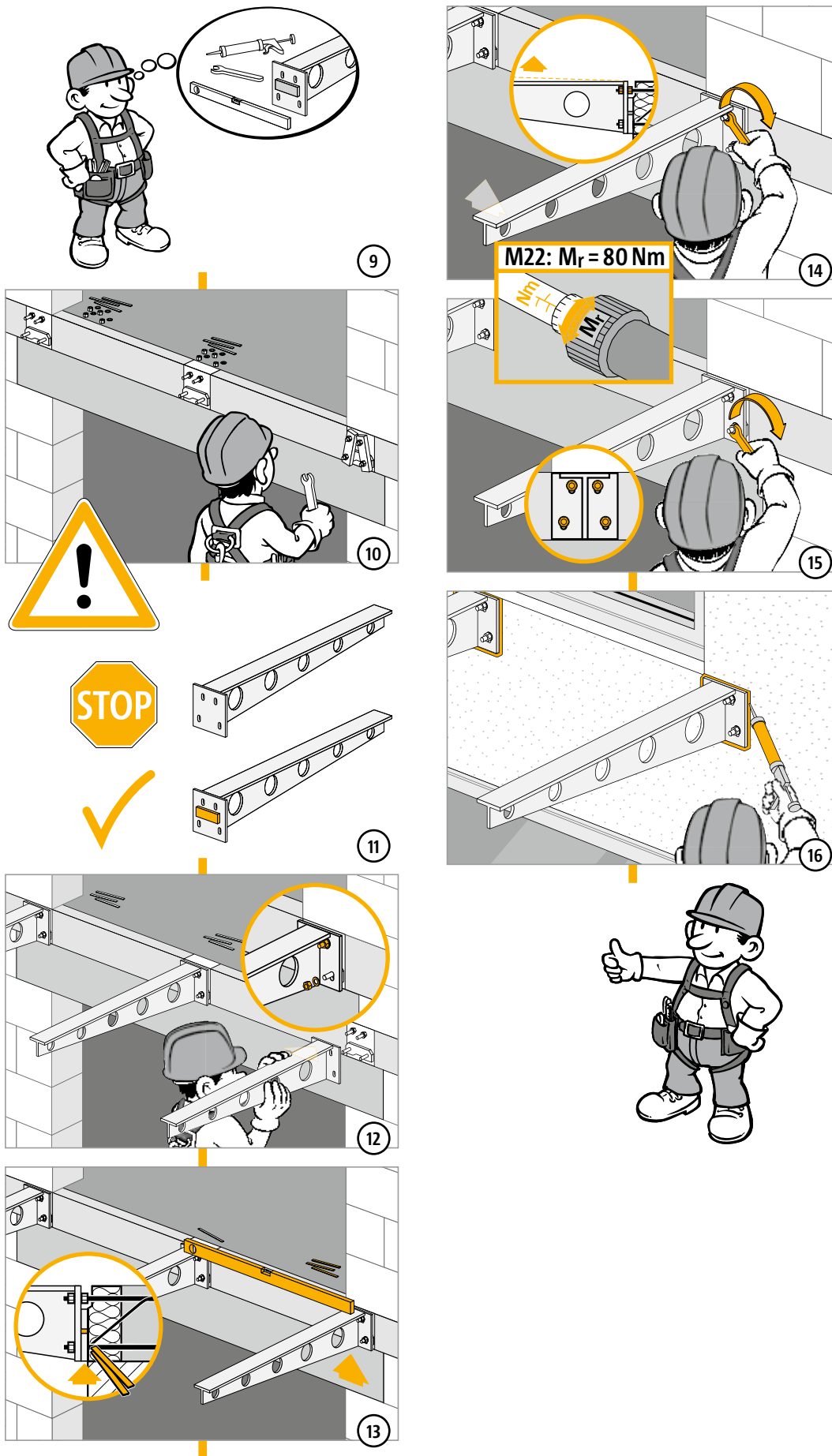

KS

Reinforced concrete-to-steel

Schöck Isokorb® type KS

Check list



- Have the member forces on the Isokorb® connection been determined at the design level?
- Is there a fire safety requirement for the overall load-bearing structure/Isokorb® (see page 138)?
- Are lifting-off forces active at the Isokorb® connection in conjunction with positive connection moments (see page 144 - 145)?
- Do the calculations of the deflection of the overall structure take into account the precamber due to the Schöck Isokorb® (see page 145)?
- Are temperature deformations assigned directly to the Isokorb® connection? Expansion joint spacing according to page 144.
- Have the the requirements and dimensions of the on-site end plate been met (refer to page 149)?
- Was sufficient reference made to the on-site end plate with butt stop which is absolutely essential?
- Has the information for the site management and/or the concrete frame contractor relating to installation tolerances been adopted in the shell plans (refer to pages 145 and 163)?
- If the Isokorb type KS20 or type KS14-VV is used with precast planks, has the cutout on the inner slab side been taken into account (see page 148)?
- Have the tightening torques for the screwed connections been marked in the implementation plan (refer to pages 153, 155 and 157)?
The nuts should be tightened without planned preload; the following tightening torques apply:

KS14 (bolt \varnothing 16): $M_r = 50 \text{ Nm}$
KS14-VV (bolt \varnothing 16): $M_r = 50 \text{ Nm}$
KS20 (bolt \varnothing 22): $M_r = 80 \text{ Nm}$

QS10 (bolt \varnothing 16): $M_r = 50 \text{ Nm}$
QS12 (bolt \varnothing 16): $M_r = 50 \text{ Nm}$

KS

Reinforced concrete-to-steel

Schöck Isokorb® type QS



Schöck Isokorb® type QS

QS

Contents	Page
Connection layouts	160
Dimensions	161
Plan views/On-site end plate/On-site connection reinforcement	162
Capacity table/Expansion joint spacing/Installation tolerances/Note	163
Method statement	164 - 165
Construction details	166
Check list	167

Reinforced concrete-to-steel

Schöck Isokorb® type QS

Connection layouts

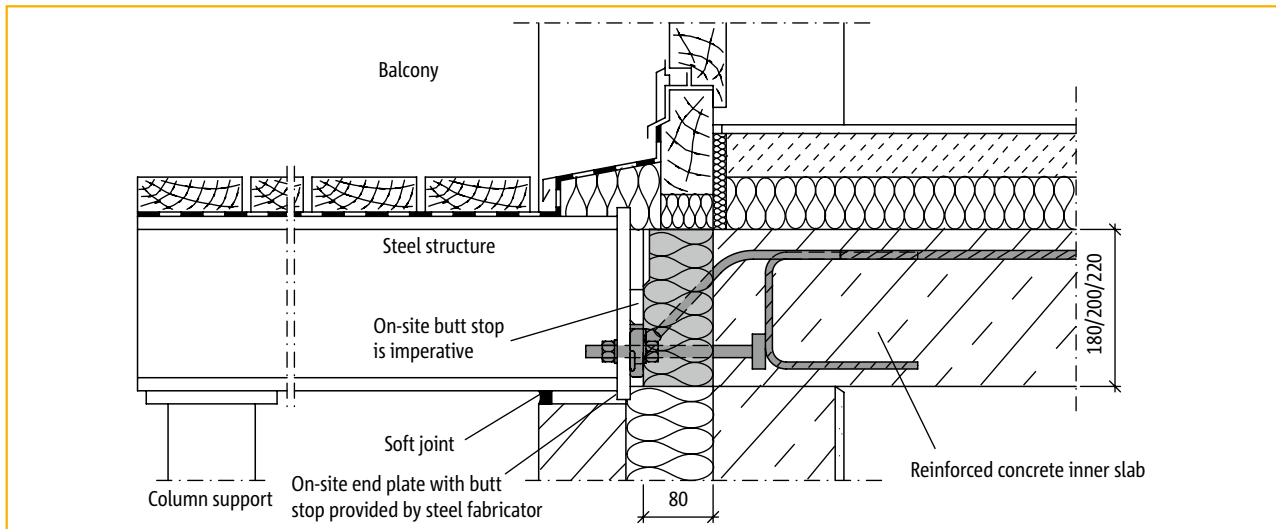

Connection with Schöck Isokorb® type QS in a door area, cavity wall

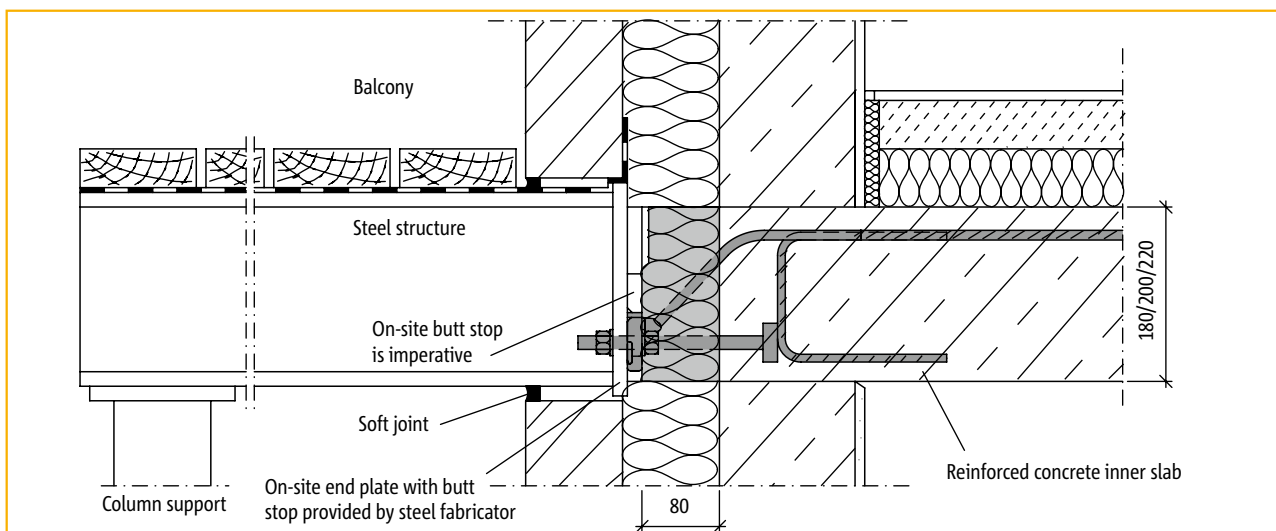

Connection with Schöck Isokorb® type QS in a wall area, cavity wall

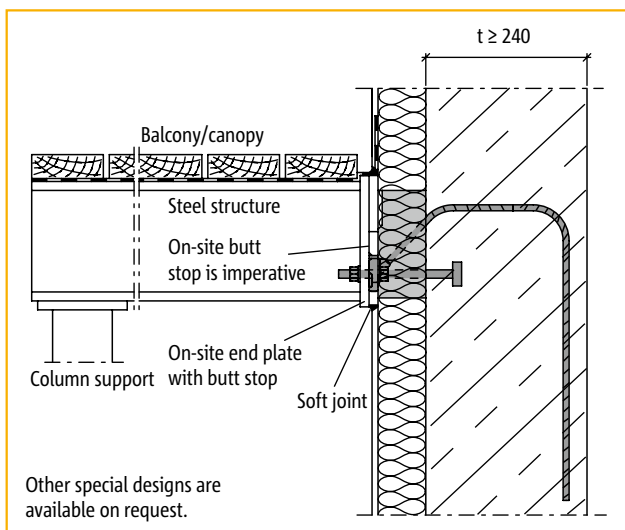

Connection with Schöck Isokorb® type QS in a wall area without adjacent inner slab - special design

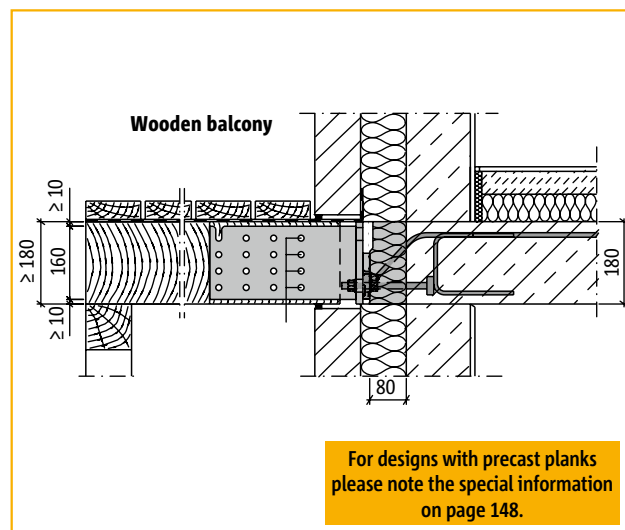

For designs with precast planks please note the special information on page 148.

Connection with Schöck Isokorb® type QSH for thermal separation of wooden members from a reinforced concrete inner slab. For more information please contact our design department under 0845 241 3390.

QS

Reinforced concrete-to-steel

Schöck Isokorb® type QS

Dimensions

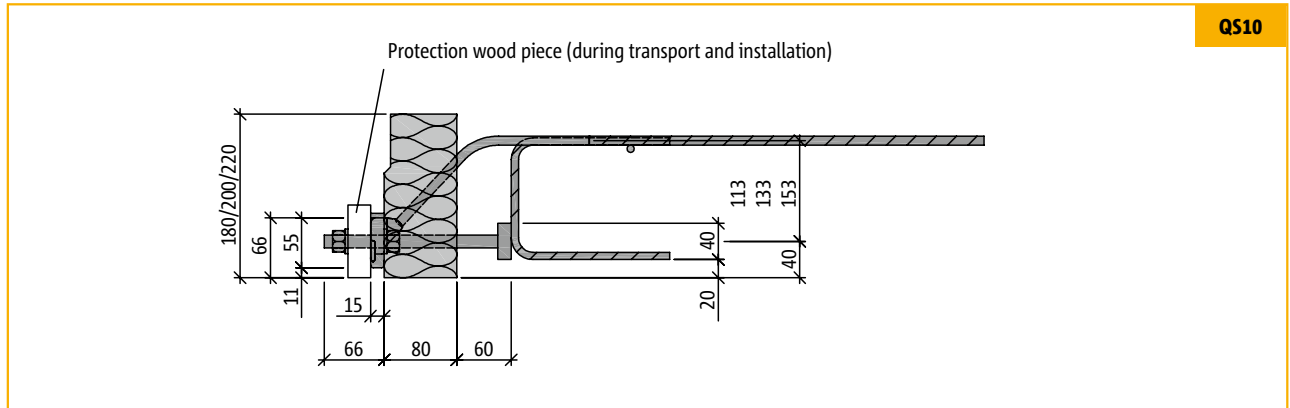

Side view: Schöck Isokorb® type QS10

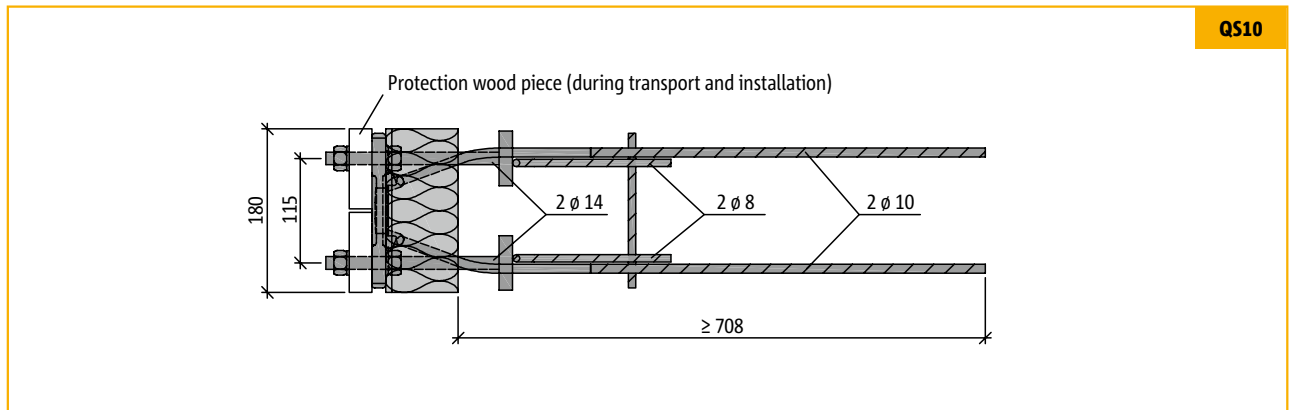

Plan view: Schöck Isokorb® type QS10

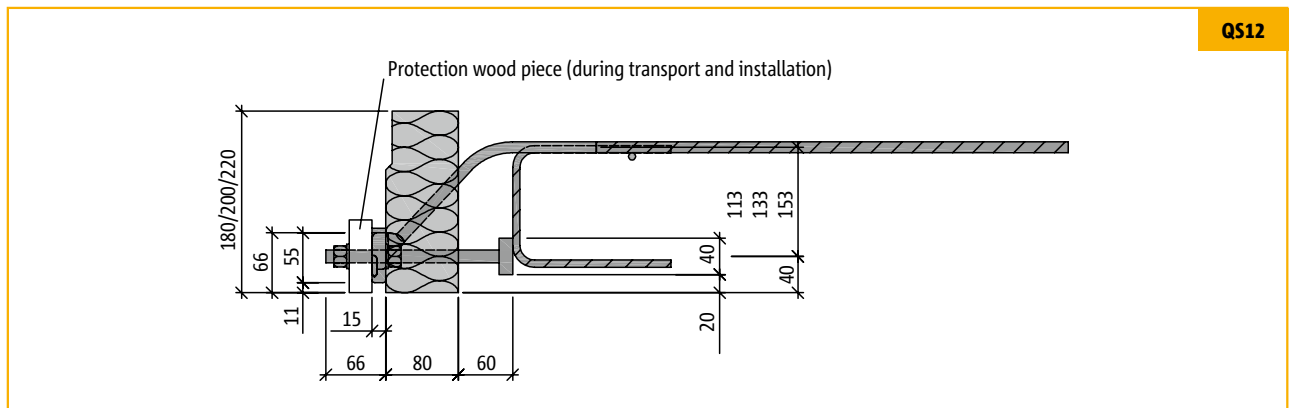

Side view: Schöck Isokorb® type QS12

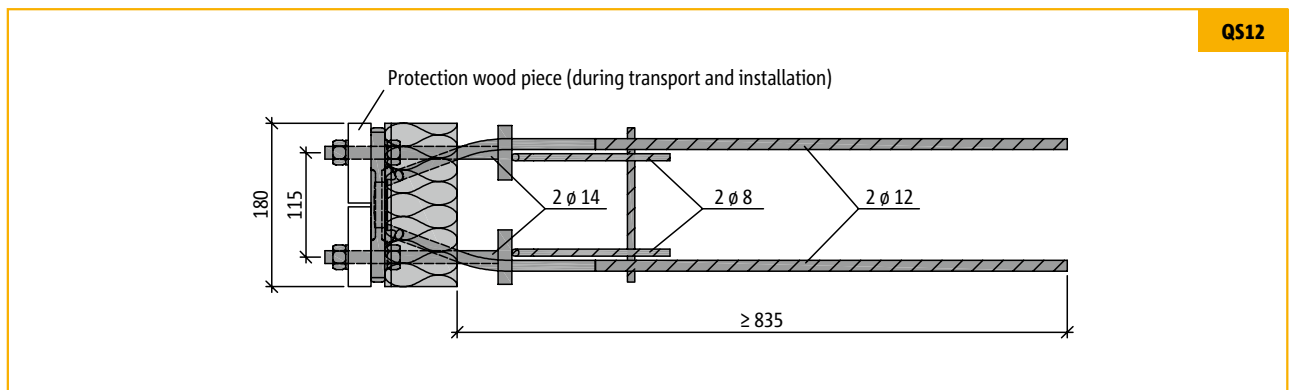

Plan view: Schöck Isokorb® type QS12

QS

Reinforced concrete-to-steel

Schöck Isokorb® type QS

Views/On-site end plate/On-site connection reinforcement

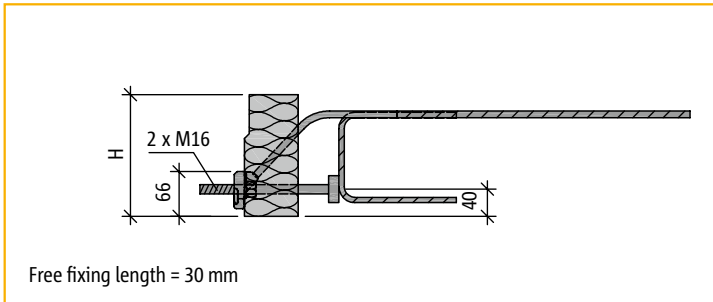

Free fixing length = 30 mm

Side view: Schöck Isokorb® type QS10 and QS12

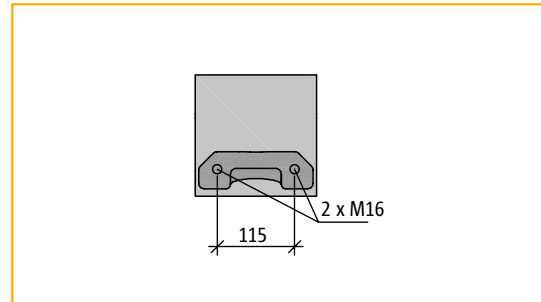

Front view: Schöck Isokorb® type QS10 and QS12

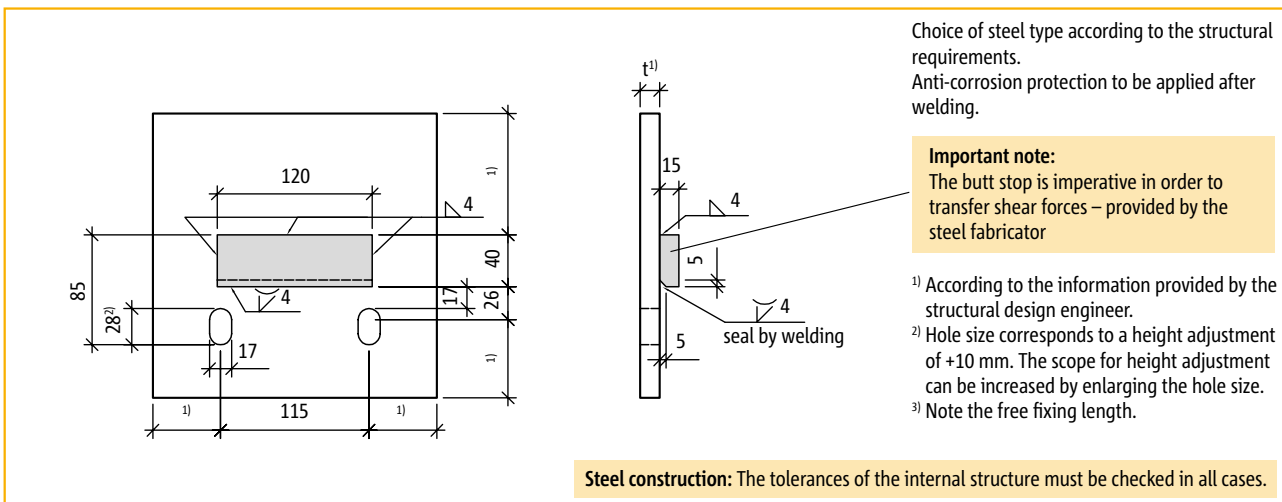

On-site end plate to Schöck Isokorb® type QS10 and QS12

On-site connection reinforcement

The 2 non-structural edge U-bars \varnothing 8 mm, are provided as standard on every type QS element (see illustration below). Further connection reinforcement for Schöck Isokorb® type QS is not required.

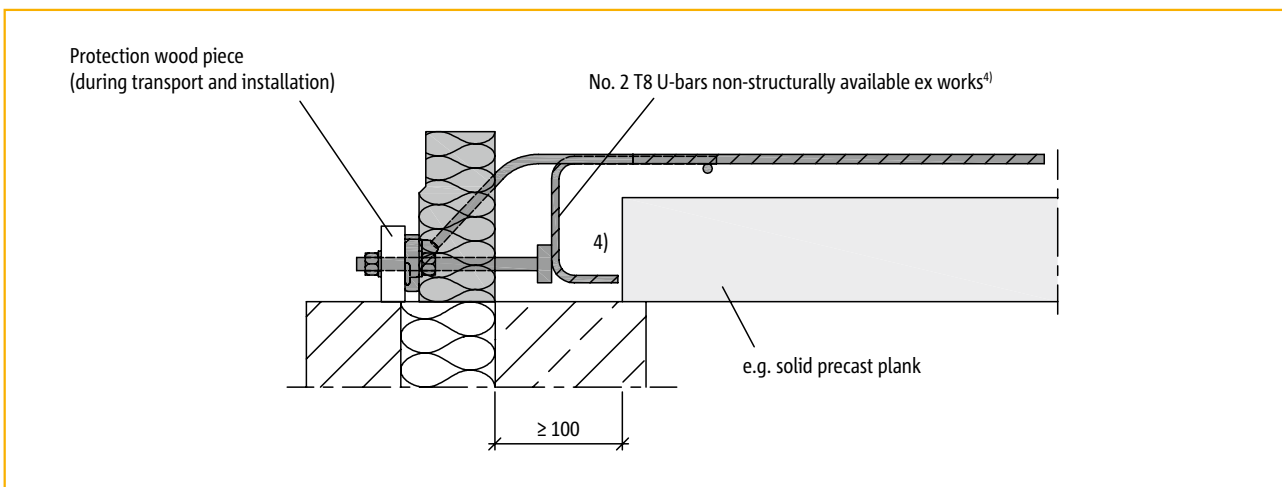

¹⁾ According to the information provided by the structural design engineer.
²⁾ Hole size corresponds to a height adjustment of +10 mm. The scope for height adjustment can be increased by enlarging the hole size.
³⁾ Note the free fixing length.
⁴⁾ When using precast planks, the lower legs of the 2 ex works U-bars T8 can be shortened on-site.

Schöck Isokorb® type QS

Capacity table/Expansion joint spacing/Installation tolerances/Note

The member forces are taken in relation to the rear edge of the end plate.

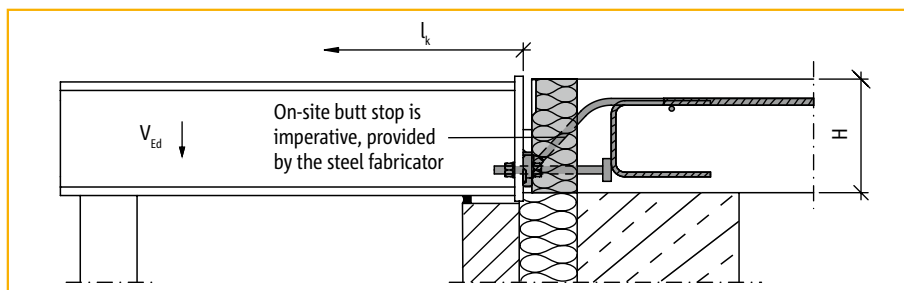

► Check list on page 167 is to be observed!

Schöck Isokorb® type	QS10	QS12
Design values for concrete strength $\geq C25/30$	Shear force capacity V_{Rd} [kN]	
	+48.3	+69.6
Height of Isokorb® H [mm] 180, 200, 220	Horizontal shear force capacity H_{Rd} [kN]	
	+4.00	+6.5
	-4.00	-6.5
	Max. expansion joint spacing [m]	
	5.70	

Expansion joint spacing

The determination of the permissible expansion joint spacing (= distance between expansion joints) is based on a balcony slab made of reinforced concrete, in case of it is fixed to the steel profiles.

If constructive measures are implemented to allow movement between the balcony slab and the individual steel profiles, then only the distances between the fixed connections are significant.

Centre and edge spacing

Minimum spacing according to the table on page 147 is to be observed.

Installation tolerances

Due to its design, the Schöck Isokorb® type QS **only allows compensation of tolerances in a vertical direction**. The tolerance is: +10 mm in a vertical direction; ± 0 mm in a horizontal direction. We recommend the use of an on-site template to secure the position. The planning engineer should inform the **concrete frame contractor** about these details in the implementation plans.

In order to ensure that the shell and the finishings join together properly without the need for modification or reworking, the **site management** must check that the tolerances are met and **take this into account in the design of the steel structure**. Dimension tolerances must be taken into account.

Note

► The on-site end plate with butt stop has to be provided by the steel fabricator.

¹⁾ In order to absorb the present horizontal force (H_{Ed}) parallel to the outside wall, a minimum shear force of $2.9 \times H_{Ed}$ must be ensured.

Schöck Isokorb® type QS

Method statement for concrete frame contracter

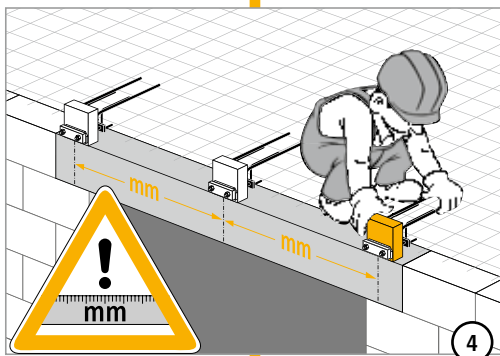
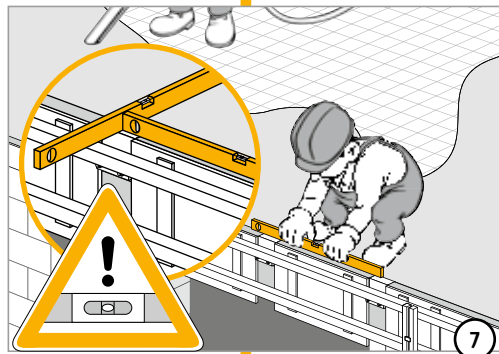
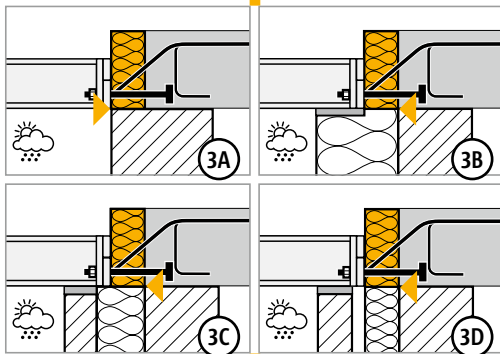
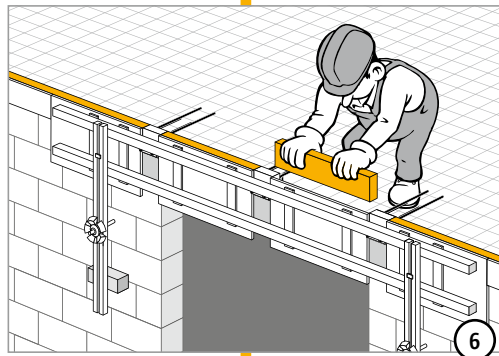
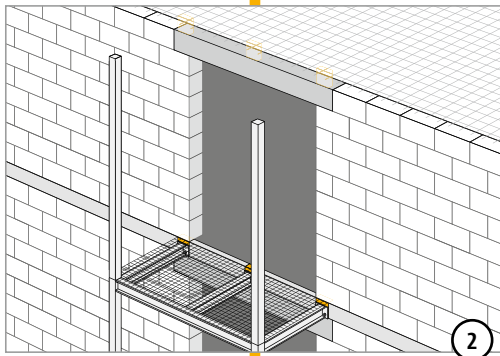
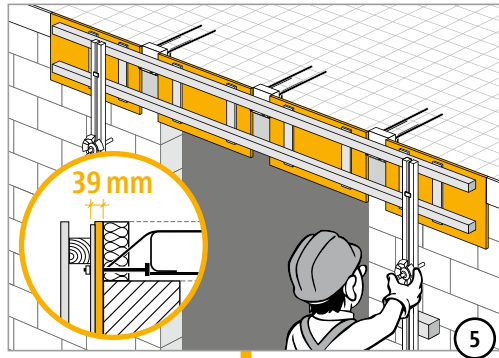
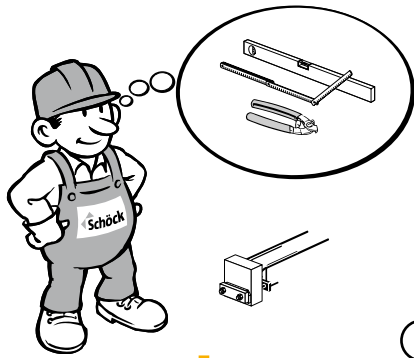

QS

Reinforced concrete-to-steel

Schöck Isokorb® type QS

Method statement for steel fabricators

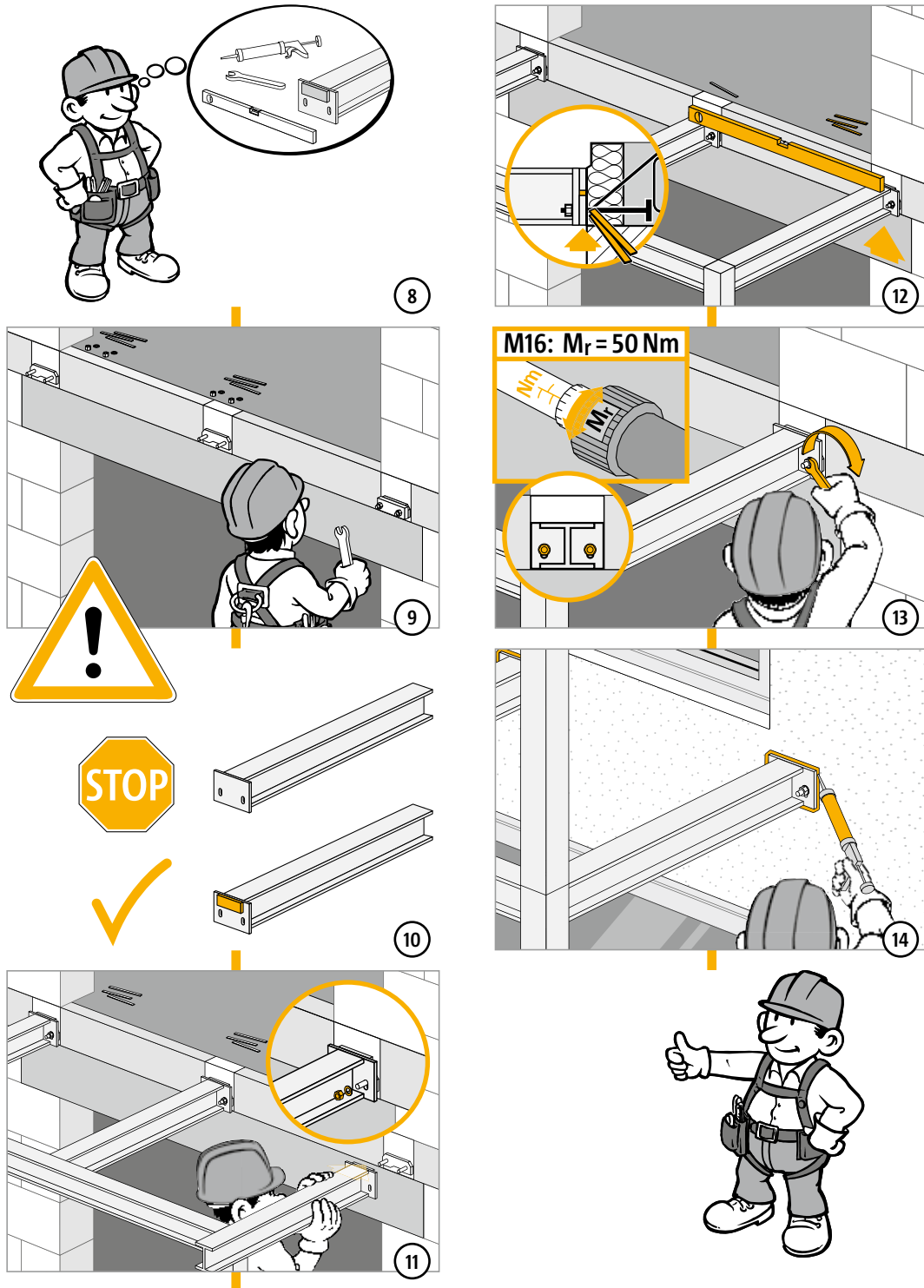

QS

Reinforced concrete-to-steel

Schöck Isokorb® type KS and QS

Construction details

KS
QS

Reinforced concrete-to-steel

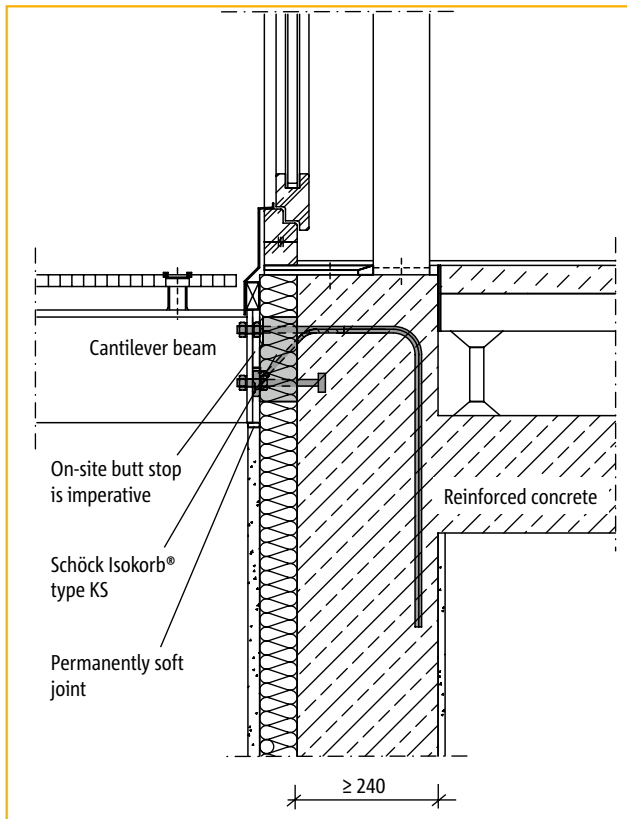

Cleaning balcony to façade

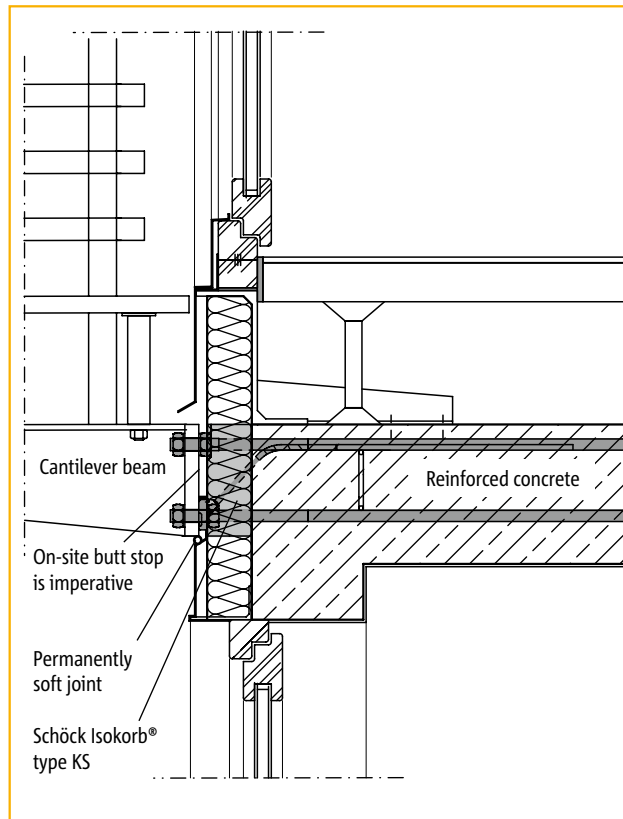

Façade balcony connection

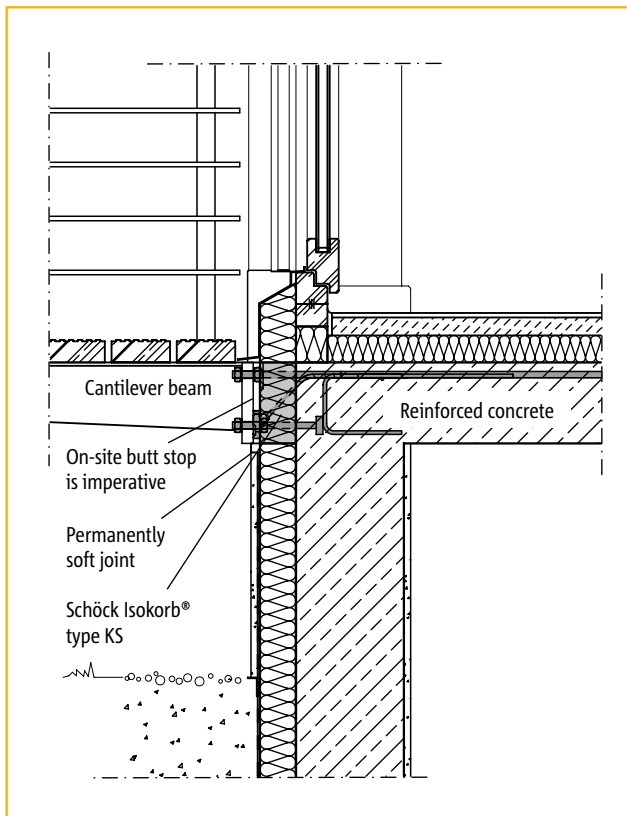

Façade balcony connection

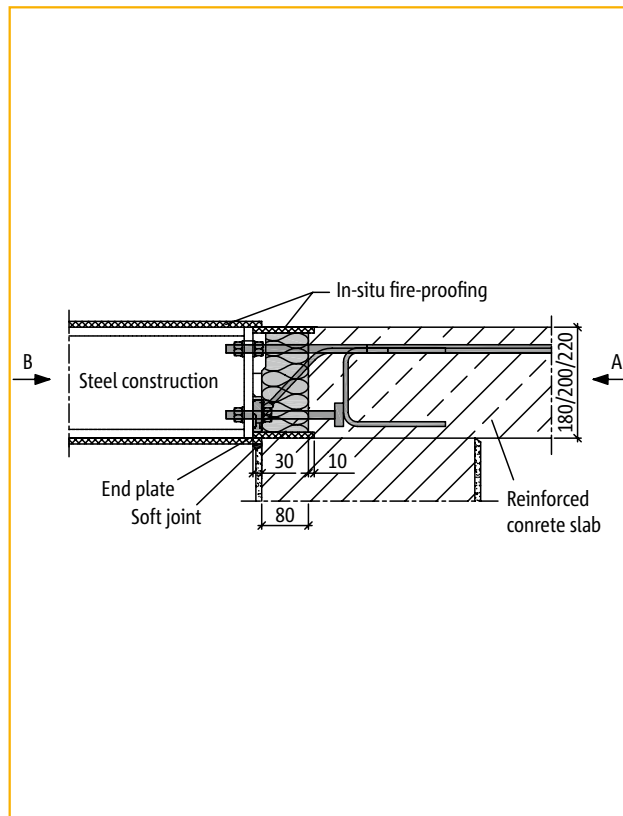

On-site fire protection plates wrapping the steel structure and the Isokorb®. A max. protection of F90 is possible.

Schöck Isokorb® type QS

Check list



- Have the member forces on the Isokorb® connection been determined at the design level?
- Is there a fire safety requirement for the overall load-bearing structure/Isokorb® (see page 166)?
- Do the calculations of the deflection of the overall structure take into account the precamber due to the Schöck Isokorb® (see page 163)?
- Are temperature deformations assigned directly to the Isokorb® connection? Expansion joint spacing according to page 163.
- Have the the requirements and dimensions of the on-site end plate been met (refer to page 162)?
- Was sufficient reference made to the on-site end plate with butt stop which is absolutely essential?
- Has the information for the site management and/or the concrete frame contractor relating to installation tolerances been adopted in the shell plans (refer to pages 162 and 163)?
- Have the tightening torques for the screwed connections been marked in the implementation plan (refer to page 165)?

The nuts should be tightened without planned preload; the following tightening torques apply:

KS14 (bolt \varnothing 16): $M_r = 50 \text{ Nm}$

KS14-VV (bolt \varnothing 16): $M_r = 50 \text{ Nm}$

KS20 (bolt \varnothing 22): $M_r = 80 \text{ Nm}$

QS10 (bolt \varnothing 16): $M_r = 50 \text{ Nm}$

QS12 (bolt \varnothing 16): $M_r = 50 \text{ Nm}$

KS
QS

Reinforced concrete-to-steel



**Schöck Isokorb®
KST modules**



for the connection of large steel beams
to a steel structure.

Schöck Isokorb® type KST

Page 171



for the connection of free cantilever steel beams to a steel structure.



Schöck Isokorb® module,
type KST-QST

Page 171



for the connection of supported steel beams to a steel structure.

Schöck Isokorb® type KST

Materials/Anti-corrosion protection/Fire protection

Schöck Isokorb® type KST - materials

Plates and sections

Chemical composition Mo-Cr-Ni-austenitic stainless steel compliant with any of BS EN 10088 grades 1.4401, 1.4404 and 1.4571 (Choice of Grade at Manufacturer's Discretion).

Mechanical properties

In accordance with BS EN 10088 – except for the following components where Schöck only accept material with mechanical properties in excess of those required for compliance with BS EN 10088.

Component	Required minimum 0.2 % proof stress (N/mm ²)	Required ultimate tensile stress (N/mm ²)	Required minimum elongation after fracture (%)
Rectangular hollow section	355	600	30
12 mm pressure plate (QST module)	275	550	40

Threaded fasteners

Grade A4-70 to BS EN ISO 3506 (corrosion resistance equivalent to BS EN 10088 Grade 1.4401)

Grade A5-70 to BS EN ISO 3506 (corrosion resistance equivalent to BS EN 10088 Grade 1.4571)

Insulation material

Polystyrene hard foam (Neopor®) $\lambda = 0.031 \text{ W}/(\text{m} \times \text{K})$

Anti-corrosion protection

- ▶ The stainless steel used for Schöck Isokorb® type KST corresponds to the material no.: 1.4401, 1.4404 or 1.4571. So the KST unit components will have a typical corrosion resistance expected for Mo-Cr-Ni austenitic stainless steels. This can be more accurately quantified by reference to specialist literature such as SCI Publication P291 – Structural Design of Stainless Steel.
- ▶ Bimetallic corrosion
Using Schöck Isokorb® type KST in conjunction with a galvanised or paint treated front plate there is no concern regarding bimetallic corrosion. Since in this application the area of the galvanised steel is greater than the area of the stainless steel (bolts, washer and butt stop) bimetallic corrosion that could lead to failure can be excluded as far as Schöck products are concerned.
- ▶ Stress corrosion cracking
An appropriate Schöck protection system needs to be provided in environments with a high chlorine content (e.g. inside indoor swimming pools, ...). For further information about atmospheric application see Steel Construction Institute Publication P291 – Structural design of stainless steel, table 2.6. For more information please contact our design department telephone 0845 241 3390.

Fire protection

The same on-site fire safety measures that apply to the overall load-bearing structure also apply to any freely accessible components of the Schöck Isokorb® type KST or to any components situated inside the insulating layer. For more information please contact our design department telephone 0845 241 3390.

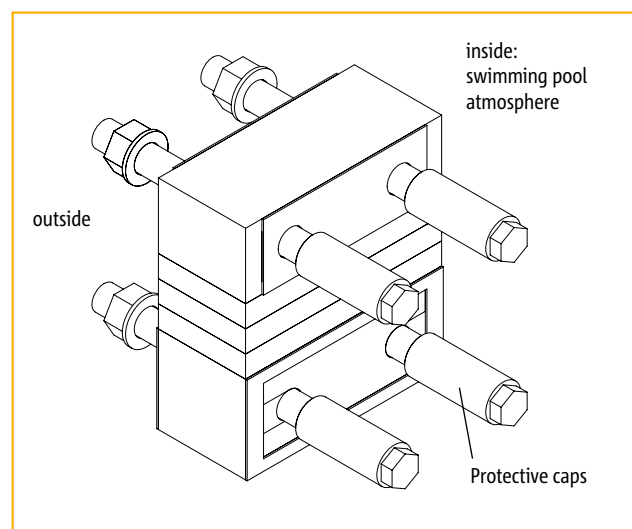

Schöck system-solution for protection in high chlorine environments

Schöck Isokorb® type KST



Schöck Isokorb® type KST

Contents	Page
Element arrangements/Connection layouts	172 - 173
Views/Dimensions	174 - 177
Design and capacity table	178
Torsion spring strength/Notes on calculations	179
Expansion joints/Fatigue resistance	180 - 181
Design configurations/Examples	182 - 194
End plate dimensioning	195
Method statement	196 - 197
Construction details	198
Check list	199

KST

Steel-to-steel

Schöck Isokorb® type KST

Element arrangements/Connection layouts

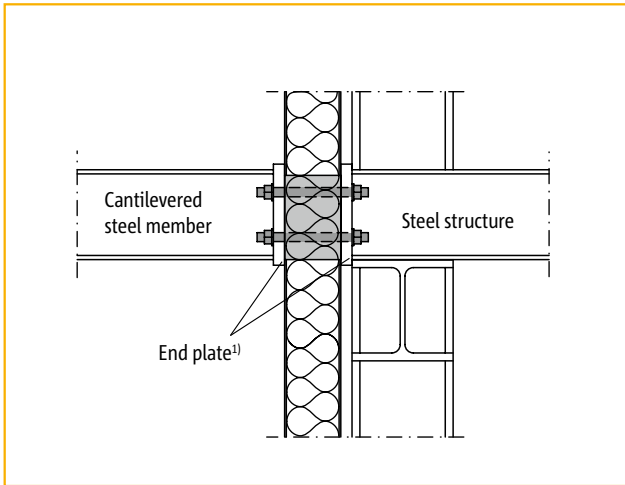

Figure 1: Schöck Isokorb® type KST for cantilevered steel structures

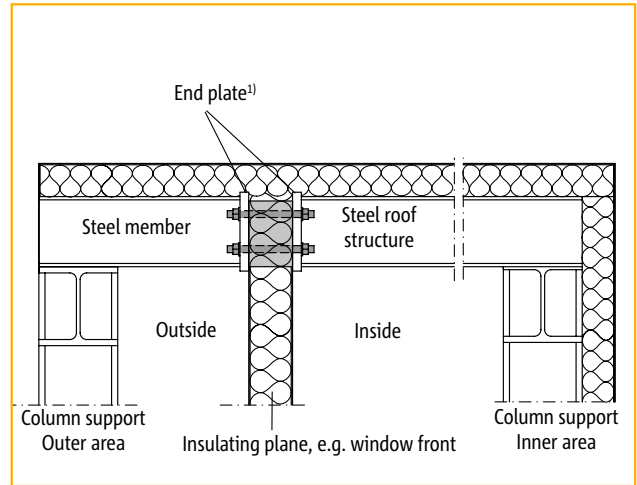

Figure 2: Schöck Isokorb® type KST for separation within the structural system

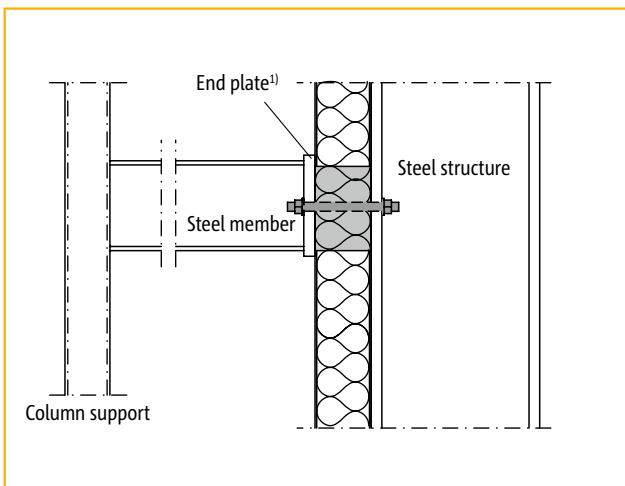

Figure 3: Schöck Isokorb® module, type KST-QST/KST-ZQST for supported steel structures

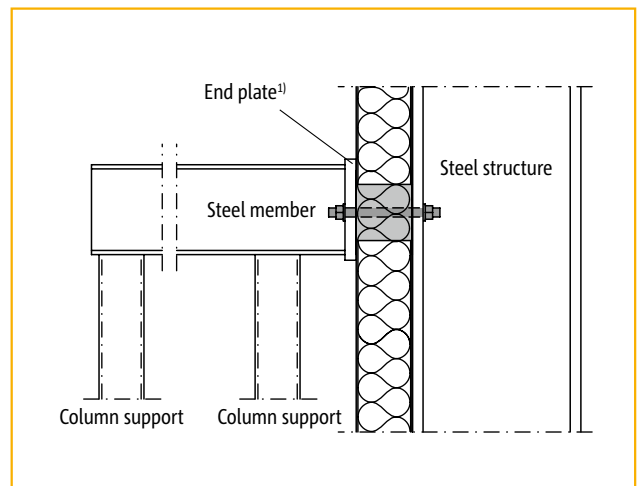

Figure 4: Schöck Isokorb® KST-ZST module for restrained steel structures

KST

Steel-to-steel

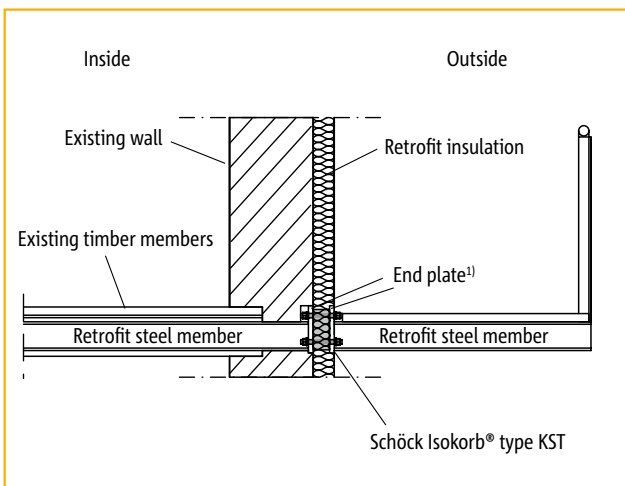
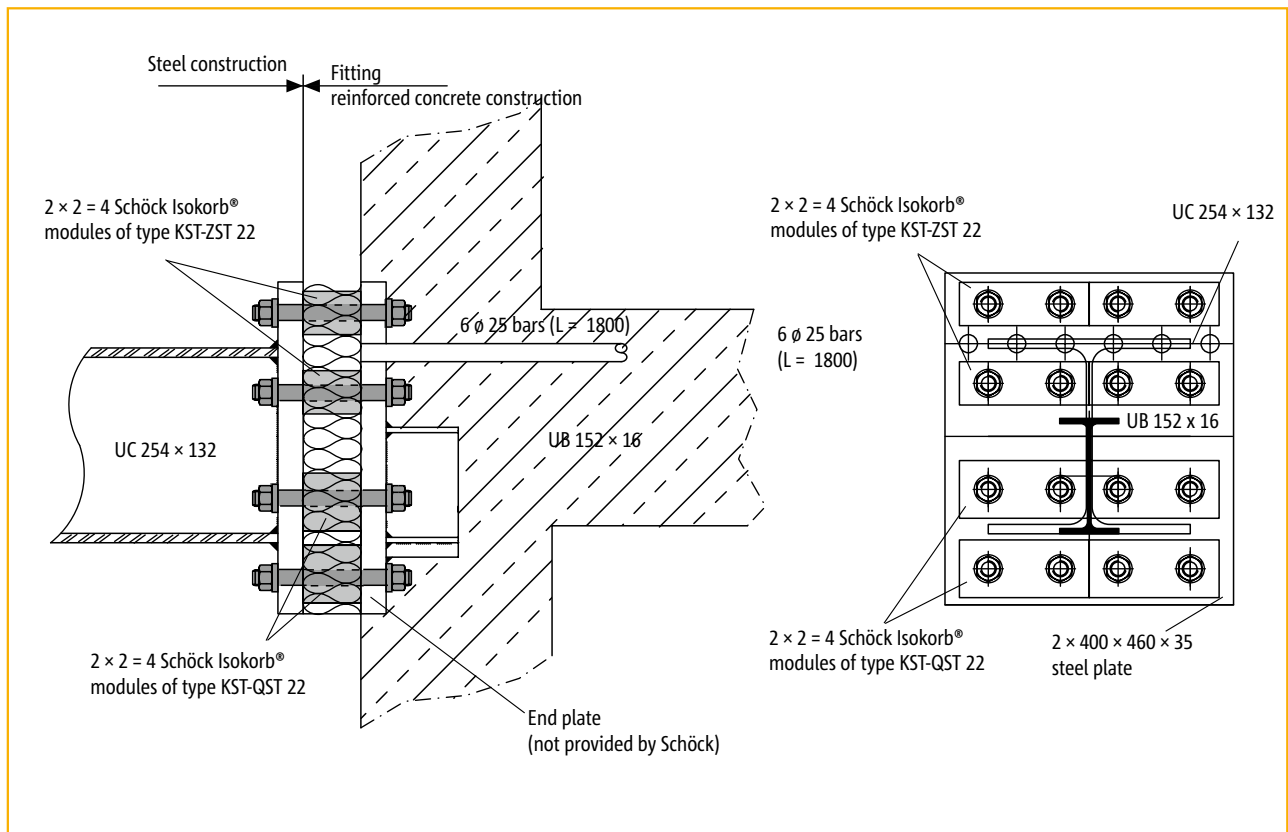

Figure 5: Schöck Isokorb® type KST for a renovation/retrofit balcony installation

¹) End plate not provided by Schöck

Schöck Isokorb® type KST

Element arrangements/Connection layout



The KST type can also be used for connections between reinforced concrete and steel. This variant can be used if the member forces are too great for the Schöck Isokorb® type KS (refer to page 144).

However, it must be ensured that the forces in the steel member are reliably transferred into the concrete via the reinforcement bars which are welded on to the on-site end plate. The engineer responsible for the design of the load bearing structure shall ensure that this is satisfied.

KST

Steel-to-steel

Schöck Isokorb® type KST

Views/Dimensions

Schöck Isokorb® type KST – basic type

The basic KST type consists of one ZST module, one QST module, one insulating adapter with a thickness of 20 mm and one insulating adapter with a thickness of 30 mm. With these modules it is possible to achieve a vertical bolt separation of up to 120 mm ($60/2 + 20 + 30 + 80/2$). If your application requires a greater distance between the bolts, this can be achieved by inserting further insulating adapters or a corresponding insulating block. The main load on the basic KST type is a shear force in the z-direction and a moment around the y-axis.

Schöck Isokorb® type KST 16

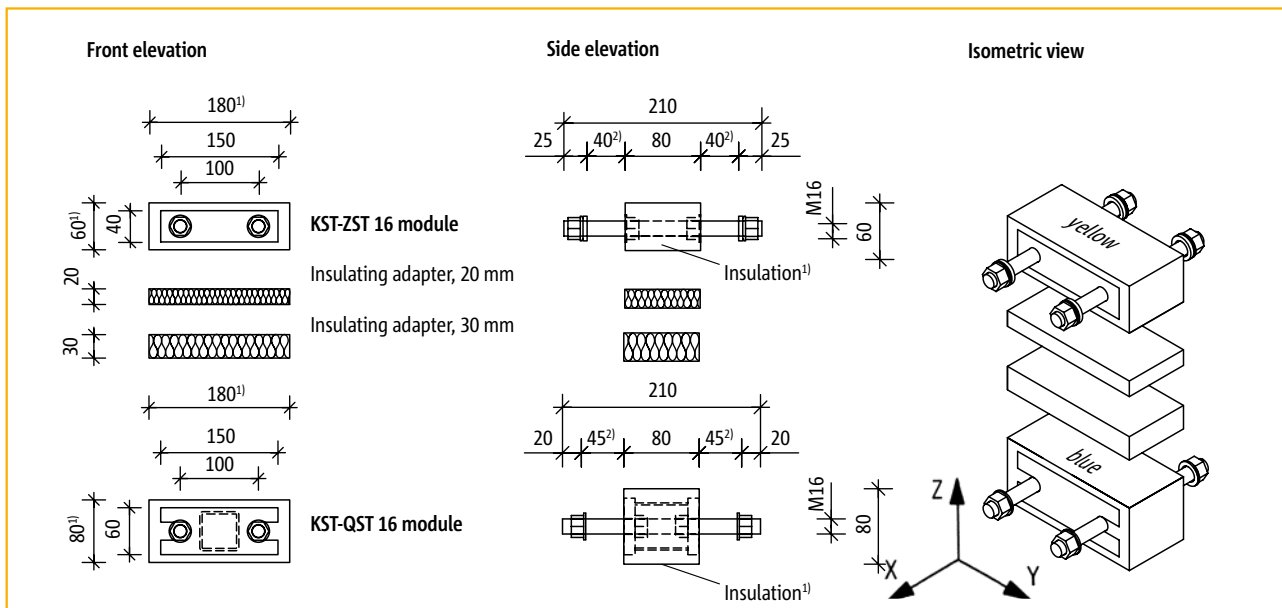

Views - Schöck Isokorb® type KST 16

KST

Schöck Isokorb® type KST 22

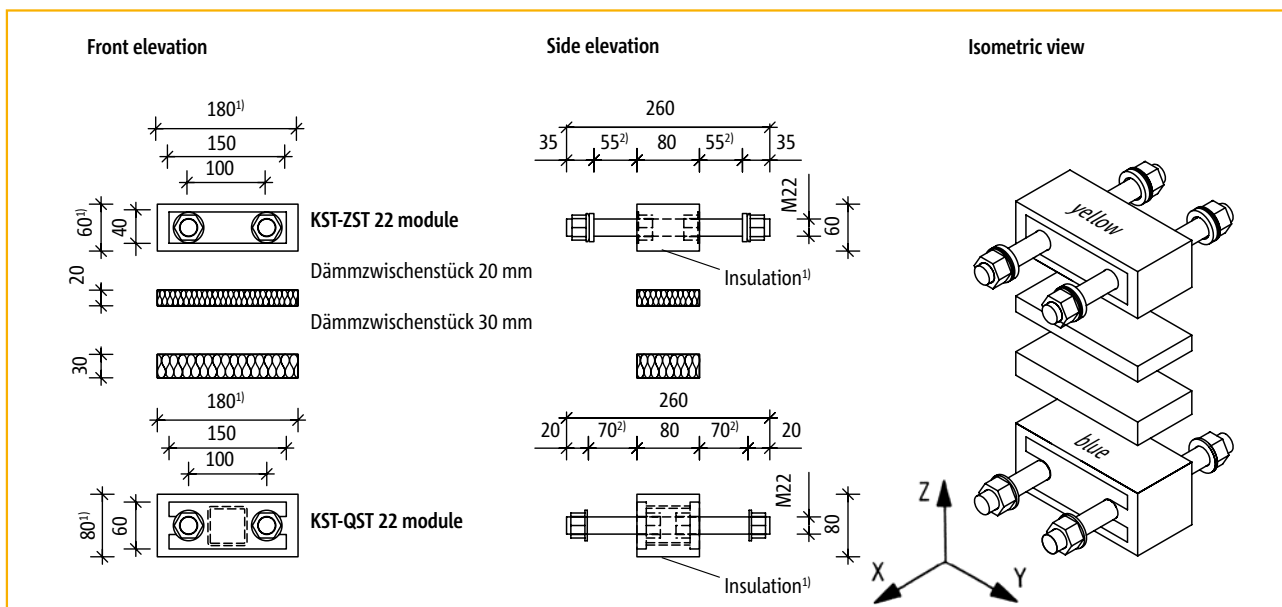

Views - Schöck Isokorb® type KST 22

¹⁾ If required, the insulating element can be cut off up to the steel plates (150 × 40 for the KST-ZST module, 150 × 60 for the KST-QST module and KST-ZQST module). The minimum distance is therefore 50 mm ($40/2 + 60/2$).

²⁾ Available fixing length

Schöck Isokorb® type KST

Views/Dimensions

Schöck Isokorb® module, type KST-ZST

The KST-ZST module is used to absorb tensile forces. It comprises one insulating element (180/60/80 mm) and two stainless threaded bars with the corresponding nuts. The outer washers take the form of a ball socket and a conical disc. This offers advantages in terms of fatigue resistance. Refer also to the section about expansion joints on pages 180 - 181. In combination with a KST-QST module, it is also possible to absorb compressive forces, although this is limited to one third of the tensile force.

Schöck Isokorb® module, type KST-ZST 16

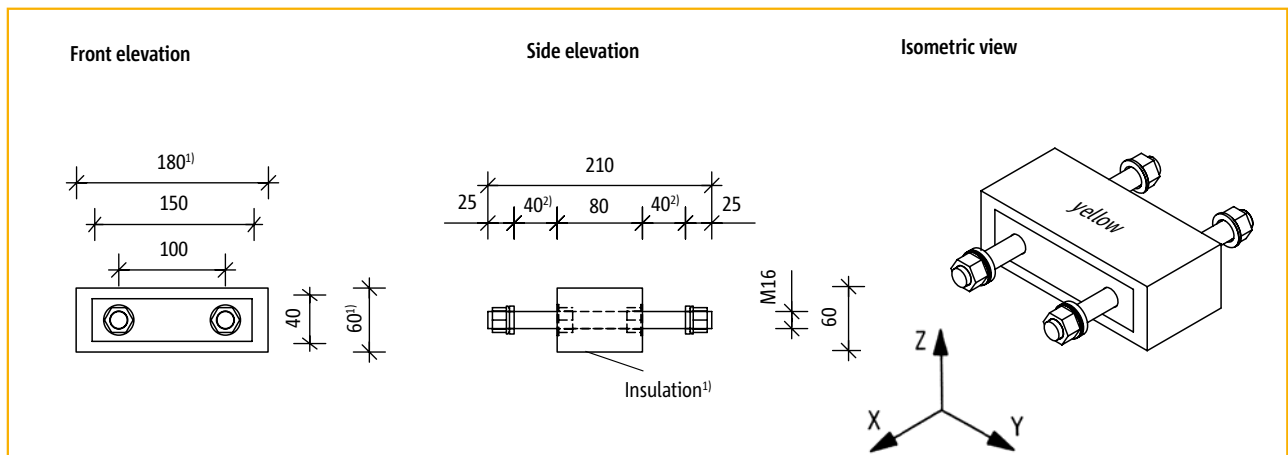

Views - Schöck Isokorb® module, type KST-ZST 16

Schöck Isokorb® module, type KST-ZST 22

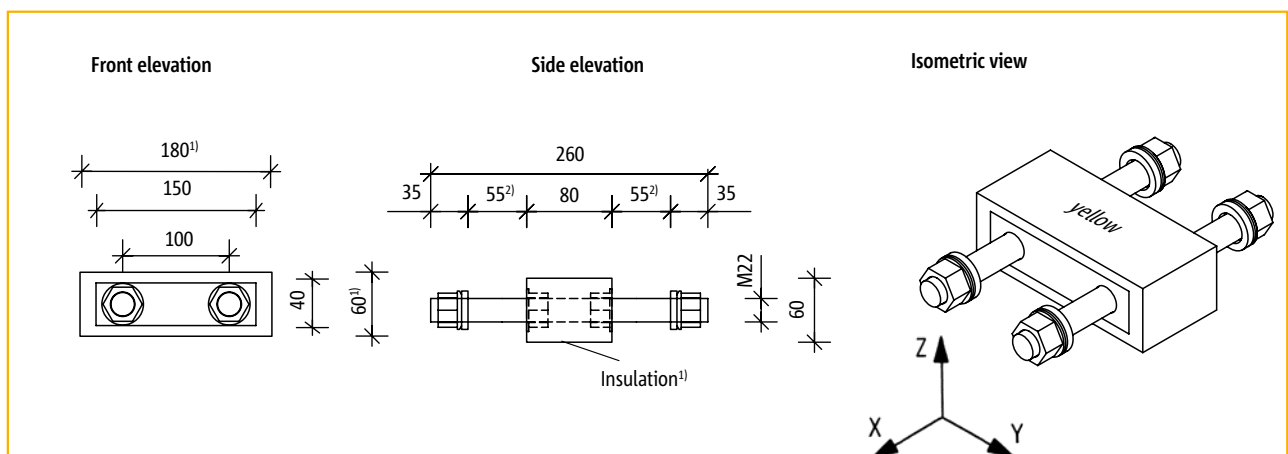

Views - Schöck Isokorb® module, type KST-ZST 22

¹⁾ If required, the insulating element can be cut off up to the steel plates (150 × 40 for the KST-ZST module).

²⁾ Available fixing length

Schöck Isokorb® type KST

Views/Dimensions

Schöck Isokorb® module, type KST-QST

The KST-QST module is used to absorb compressive forces and shear forces. It consists of an insulating element (180/80/80 mm), two stainless threaded bars with corresponding nuts and a rectangular hollow section which is welded into the module. The rectangular hollow section transmits the shear forces. The element can transmit forces in the x, y and z-direction. Within a KST connection, the KST-QST module is located in the area in which pressure is exerted due to the self weight. Different load combinations, including tensile forces, within a KST connection, can be carried by the KST-QST module, although the interaction condition

$$3V_d + 2H_d + F_{t,d} = \max F_{t,d} \leq F_{t,Rd} \text{ must be satisfied.}$$

Schöck Isokorb® module, type KST-QST 16

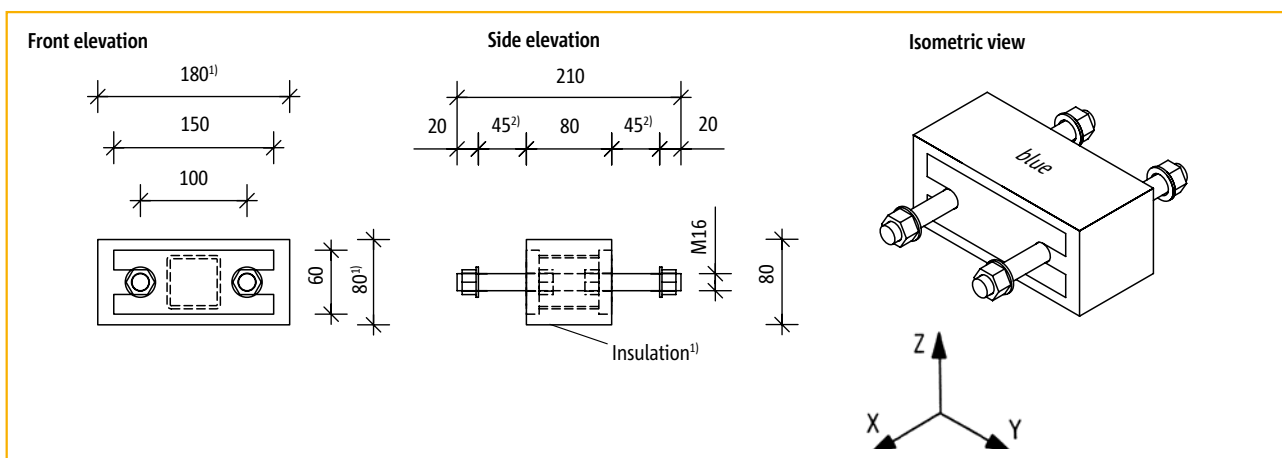

Views - Schöck Isokorb® module, type KST-QST 16

KST

Schöck Isokorb® module, type KST-QST 22

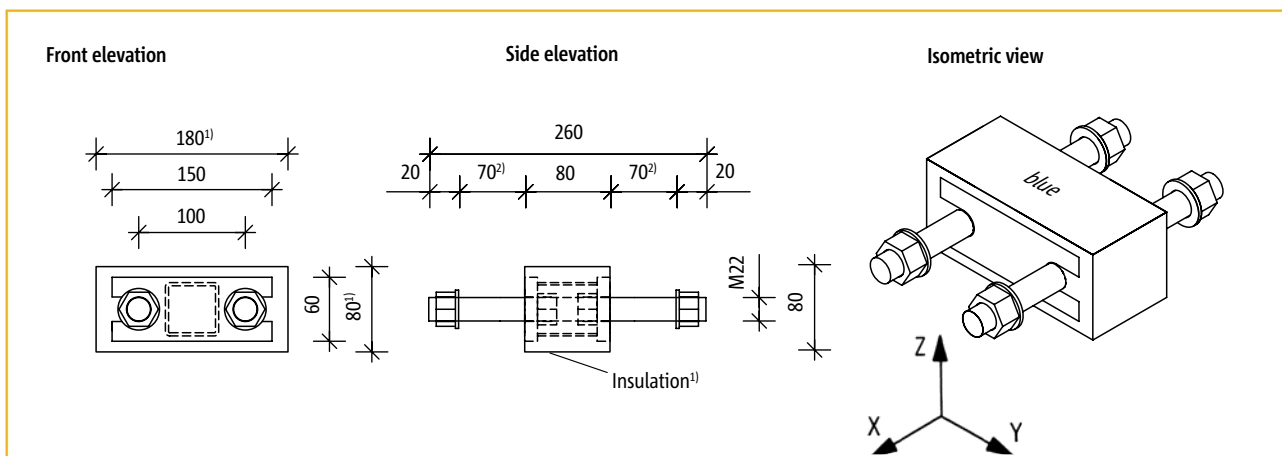

Views - Schöck Isokorb® module, type KST-QST 22

Steel-to-steel

¹⁾ If required, the insulating element can be cut off up to the steel plates (150 × 60 for the KST-QST module and the KST-ZQST module).

²⁾ Available fixing length

Schöck Isokorb® type KST

Views/Dimensions

Schöck Isokorb® module, type KST-ZQST

The KST-ZQST module combines the technical features of the KST-ZST module with those of the KST-QST module. It should be used for applications in which tensile forces are continuously transmitted and, at the same time, horizontal forces resulting from temperature deformations are transferred from the outer steel structure into the connection. Special two-part washers provide fatigue resistance.

Schöck Isokorb® module, type KST-ZQST 16

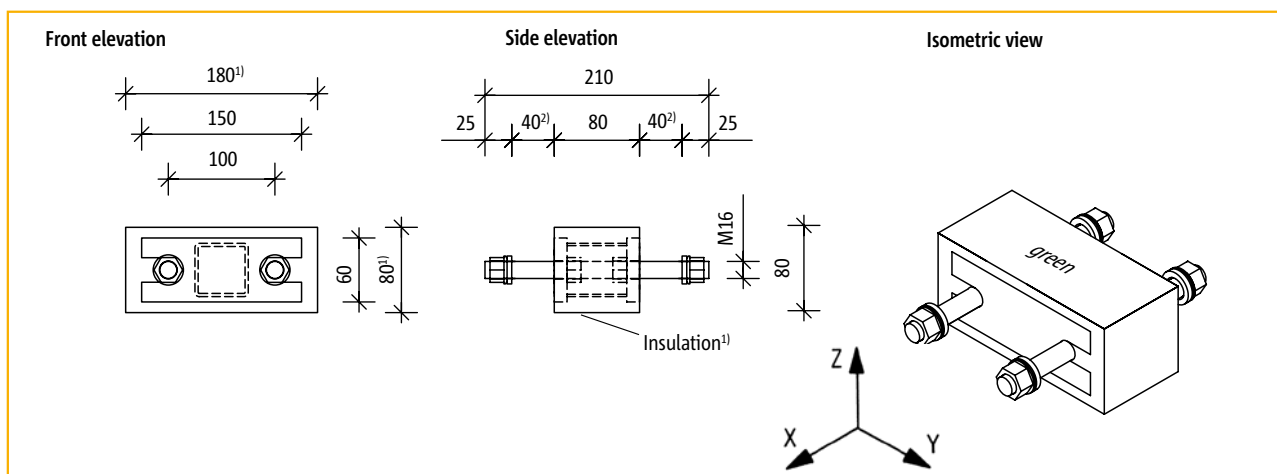

Views - Schöck Isokorb® module, type KST-ZQST 16

Schöck Isokorb® module, type KST-ZQST 22

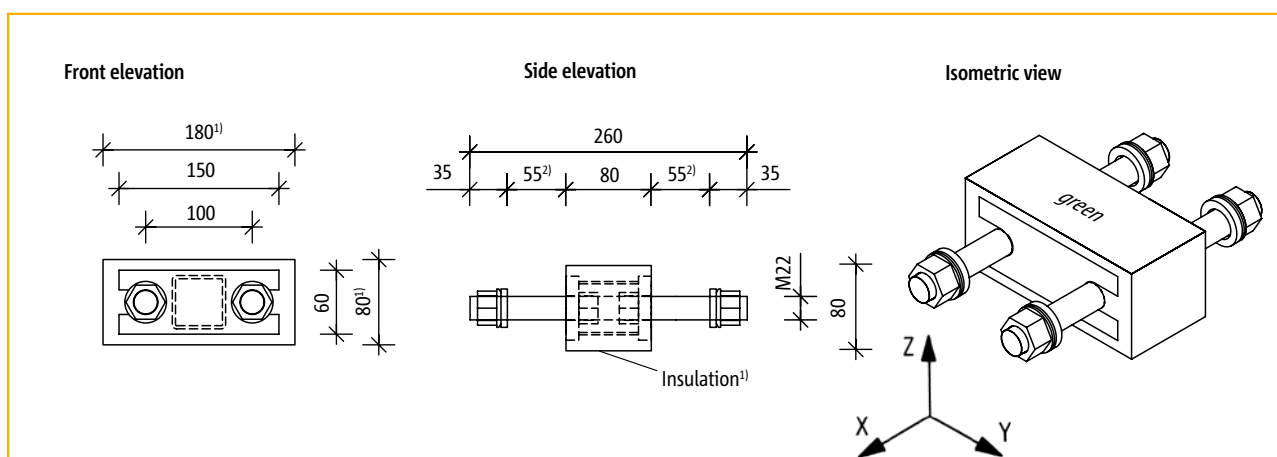

Views - Schöck Isokorb® module, type KST-ZQST 22

KST

Steel-to-steel

¹⁾ If required, the insulating element can be cut off up to the steel plates (150 × 60 for the KST-QST module and the KST-ZQST module).

²⁾ Available fixing length

Schöck Isokorb® type KST

Design and capacity table

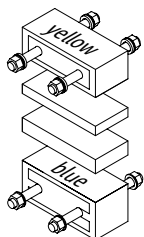
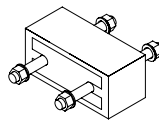
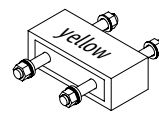
Schöck Isokorb® type			 KST-QST: blue KST-ZQST: green			
	KST 16	KST 22	KST-QST 16 module KST-ZQST 16 module	KST-QST 22 module KST-ZQST 22 module	KST-ZST 16 module	KST-ZST 22 module
$H_{y,Rd}$	$\pm 6 \text{ kN}^{5)}$	$\pm 6 \text{ kN}^{5)}$	$\pm 6 \text{ kN}^{3)5)}$	$\pm 6 \text{ kN}^{3)5)}$	0 kN	0 kN
$V_{z,Rd}$	30 kN	36 kN	$30 \text{ kN}^{3)}$	$36 \text{ kN}^{3)}$	0 kN	0 kN
$F_{x,t,Rd}$ $F_{x,c,Rd}$	116.8 kN ⁶⁾	225.4 kN ⁶⁾	$116.8 \text{ kN}^{3)}$	$225.4 \text{ kN}^{3)}$	$F_t = 116.8 \text{ kN}$ $F_c = 0 \text{ kN}$	$F_t = 225.4 \text{ kN}$ $F_c = 0 \text{ kN}$
$M_{y,Rd}$	$a \times F_{x,t,Rd}^{1)}$	$a \times F_{x,t,Rd}^{1)}$	0 kNm ⁴⁾	0 kNm ⁴⁾	0 kNm	0 kNm
$M_{z,Rd}$	2)5)	2)5)	2)5)	2)5)	0 kNm	0 kNm

F_{Rd}	resistance design [per module]
$F_{t,Rd}$	for the tensile loading capacity of the bolts
$F_{c,Rd}$	for the compression loading capacity of the bolts

KST

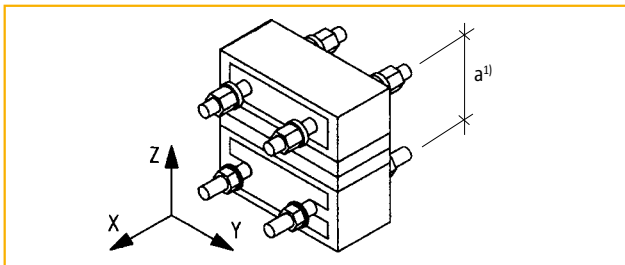

Schöck Isokorb® type KST

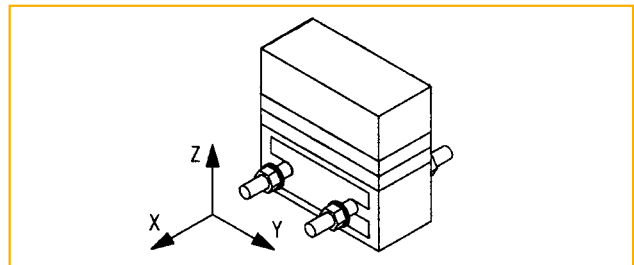

Schöck Isokorb® module, type KST-QST/KST-ZQST

- ¹⁾ a = distance between the tension bars and compression bars of the Isokorb® element (inner lever arm), minimum possible axis separation between tension bars and compression bars = 50 mm (without insulating adapters after processing of the polystyrene – see pages 174 - 177¹⁾).
- ²⁾ We recommend that you discuss the static system and calculations with the Schöck design department, tel. 0845 241 3390.
- ³⁾ The interaction $3 V_z + 2 H_y + F_{x,t} = \max F_{x,t,d} \leq F_{x,t,Rd}$ needs to be taken into account in the event of simultaneous tensile force and shear force loads.
- ⁴⁾ When using at least two modules arranged one above the other, it is possible to transfer both positive and negative forces (moments and shear forces) in accordance with the design variants on pages 183 - 194.
- ⁵⁾ Please make sure that you read the notes on expansion joints/fatigue resistance on pages 180 - 181 below.
- ⁶⁾ If the KST-ZST module is subjected to pressure loads within a KST connection (e.g. wind loads generating slight lift-off), then the KST-ZST module can absorb a maximum of $1/3 F_{x,t,Rd}$ as a compressive force. The interaction (footnote 3) must also be noted in this load scenario.

Steel-to-steel

Schöck Isokorb® type KST

Torsion spring strength/Notes on calculations

Estimation of deformation variables due to M_k in the Schöck Isokorb® connection

Torsion spring strength/buckling angle resulting from bending moment			
Design variants	Torsion spring strength c [kNcm/rad]	Buckling angle φ [rad]	Static model for the estimation of flexural stiffness
No. 3 - see page 183	$3\,700 \times a^2$	$\varphi = \frac{M_k}{C}$	
No. 4 - see page 184	$6\,000 \times a^2$		
No. 5 - see page 186	$5\,200 \times a^2$		
No. 6 - see page 186	$12\,000 \times a^2$		
No. 7 - see page 187	$24\,000 \times a^2$		
No. 8 - see page 188	$6\,000 \times a^2$		
No. 9 - see page 190	$12\,000 \times a^2$		
No. 10 - see page 192	$24\,000 \times a^2$		

a [cm] = refer to the design variants on pages 182 - 194.
 M_k = bending moment from characteristic values for the effects around the (existing M).
 Deformations resulting from normal forces and shear forces can be ignored.
 Values in table above assume average secant modulus of stainless steel under working load of 17 900 kN/cm²

Possible modular combinations of the basic types are shown on the next pages.

Notes on calculations

- ▶ **Basis:**
 Type certification (LGA Nürnberg S-N 010415)
 The Schöck Isokorb® type KST has been classified by the DIBt (German Institute for Construction Technology) as the subject of structural standards with type certification. Approval is not required as it is a modular system.
 The design capacities of the Schöck Isokorb® type KST have been independently checked and approved as compliant to BS 5950:2000 in conjunction with SCI Publication P291 – Structural Design of Stainless Steel.
- ▶ **Certification:**
 The static calculations to Eurocode 3 for Schöck Isokorb type KST, when used in conjunction with BS 5950-1:2000 and Steel Construction Institute Publication P291, have been approved by the Flint & Neill Partnership, London.
- ▶ **End plate thickness:**
 In the case of the connection of I-profiles in accordance with the design variants below, the indicated end plate thicknesses, using mild steel S235, can be adopted without further verification or proof. Smaller end plate thicknesses can be obtained with more accurate verification or proof.
 If the geometry is different then the end plates will need to be verified separately (e.g. connection of a U-profile, flat sheet metal, ...).
- ▶ **Adjacent web thickness:**
 If webs of adjacent girders are less than 3.5 mm or considered to be “slender” or “non-compact” classification to BS 5950, web to be checked for local compression effects induced by QST module.
- ▶ **Dynamic loads:**
 The Schöck Isokorb® type KST is only intended for use with primarily static loads.

Schöck Isokorb® type KST

Expansion joints/Fatigue resistance

Changing temperatures cause changes in length of the steel members and thus cause fluctuating stresses to arise in the Isokorb® elements which are only passed on in part through the thermal separation.

Loads on the Isokorb® connections due to temperature deformations of the external steel construction should therefore generally be avoided.

If, nonetheless, temperature deformations are assigned directly to the Isokorb® connection, then the Isokorb® type KST construction will be fatigue-resistant up to a construction length of 6 m by virtue of its special components (KST-QST module, KST-ZQST module: sliding film on the pressure plate; KST-ZST module, KST-ZQST module: 2-part special washer). At greater lengths an expansion joint should be positioned after no more than 6 m.

Horizontal slots are needed in the on-site end plate for the KST-QST module and KST-ZQST module used in the compression zone if horizontal temperature deformations are to be introduced. These must permit horizontal movements of ± 2 mm. In this case, horizontal shear forces can only be absorbed non-structurally via friction.

Examples of the arrangement and design of expansion joints:

Key:

- Schöck Isokorb®
- Expansion joint
- x FIXED: No slots required
- ↔ MOVEABLE: Horizontal slots in the on-site front plate for KST-QST module, KST-ZQST module (compression zone)

KST

Steel-to-steel

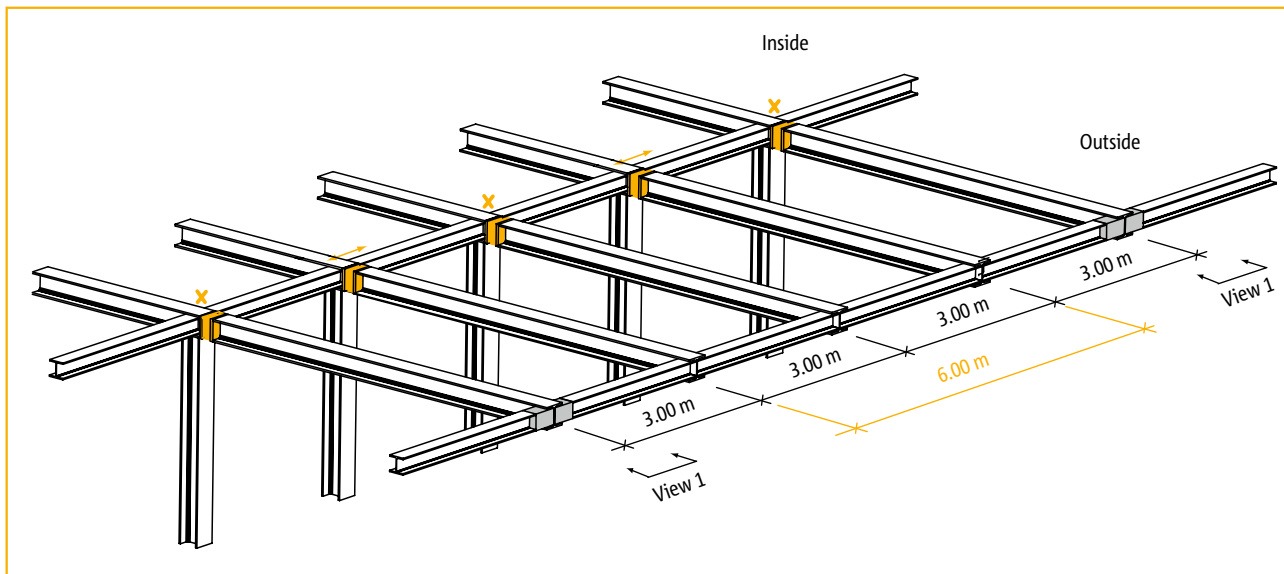

Example showing the arrangement of expansion joints, variant 1

Schöck Isokorb® type KST

Expansion joints/Fatigue resistance

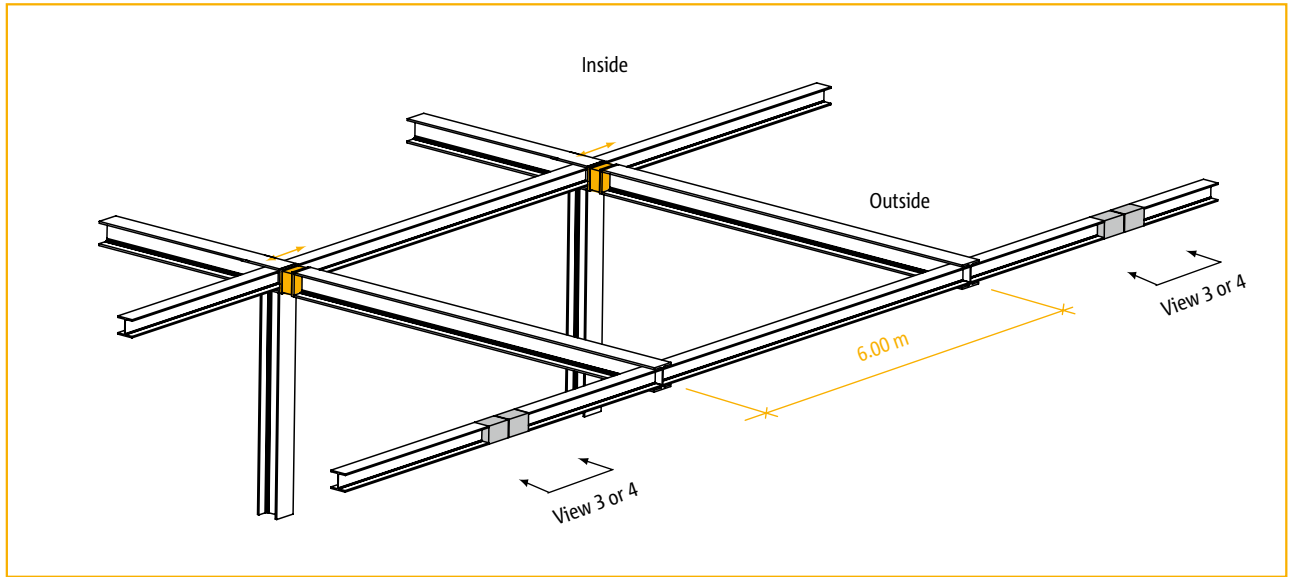

Example showing the arrangement of expansion joints, variant 2

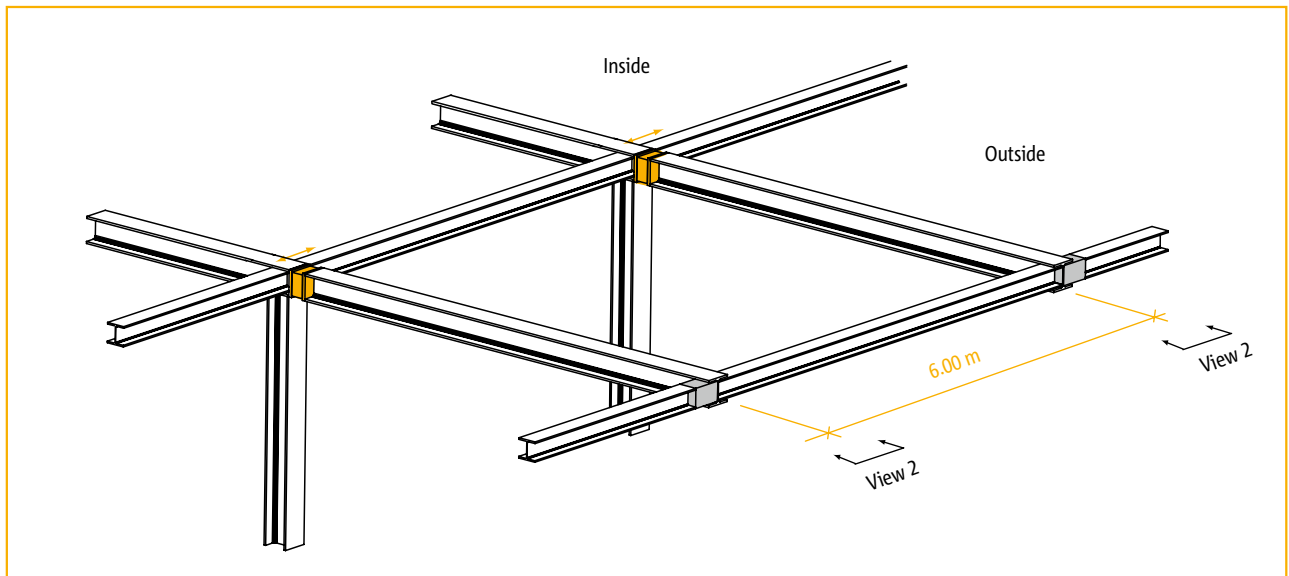

Example showing the arrangement of expansion joints, variant 3

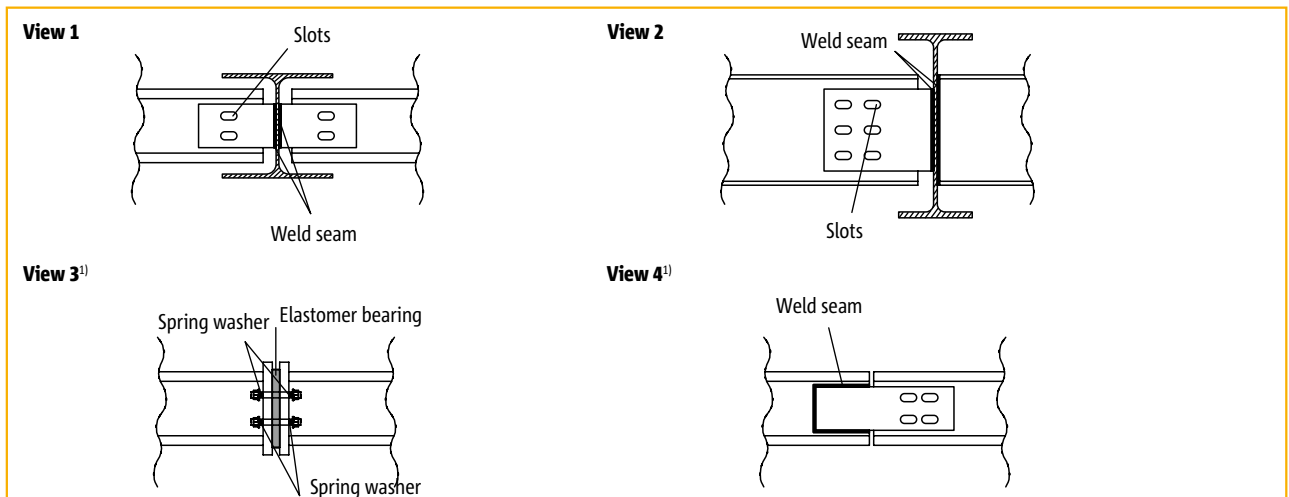

¹⁾ Only partial moment transfer possible.

Schöck Isokorb® type KST-QST 16 module, KST-ZQST 16 module

Design configuration and example

1 Side elevation

Steel member with end plate according to structural requirements

Plan elevation

KST-QST 16 module, KST-ZQST 16²⁾ module

H_{Rd}	6 kN ³⁾
V_{Rd}	30 kN
$F_{t,Rd}, F_{c,Rd}$	116.8 kN

Interaction between $V_d, H_d, F_{t,d}$:

$$3 V_d + 2 H_d + F_{t,d} = \max F_{t,d} \leq F_{t,Rd}$$

¹⁾ Minimum end plate thicknesses [d] without detailed verification, using mild steel S235:

$\frac{\max F_{t,d}}{F_{t,Rd}} = \frac{F_{c,d}}{F_{c,Rd}} \leq 1.0$: 30 mm
≤ 0.75	: 25 mm
≤ 0.5	: 20 mm

²⁾ The Schöck Isokorb® type KST-ZQST 16 module should be used for applications in which tensile forces need to be transferred continuously into the connection and in which, at the same time, horizontal forces resulting from temperature deformation of the external steel structure are transferred into the connection. Special two-part washers provide fatigue resistance. Refer to pages 180 - 181 for the expansion joint spacings.

³⁾ Always refer to the information about expansion joints/fatigue resistance on pages 180 - 181.

Schöck Isokorb® modules, type KST-QST 16, KST-ZQST 16²⁾

Example showing a supported connection of an UB 152 × 89 with a KST-QST 16 module

Loads: $V_{z,d} = 25$ kN $H_d = \pm 3$ kN (from wind loads) $F_{t,d} = 30$ kN or $F_{c,d} = 80$ kN

Verifications for KST-QST 16 module

Shear force

$$\frac{V_{z,d}}{V_{z,Rd}} < 1.0 \quad \frac{H_d}{H_{Rd}} < 1.0 \quad \frac{V_{z,d}/V_{z,Rd,QST16}}{H_d/H_{Rd,QST16}} = \frac{25 \text{ kN}/30 \text{ kN}}{3 \text{ kN}/6 \text{ kN}} = 0.83 < 1.0$$

Compression

$$\frac{F_{c,d}}{F_{c,Rd}} < 1.0 \quad \frac{F_{c,d}/F_{c,Rd,QST16}}{F_{t,d}/F_{t,Rd,QST16}} = \frac{80 \text{ kN}/116.8 \text{ kN}}{30 \text{ kN}/116.8 \text{ kN}} = 0.68 < 1.0$$

Tensile force (see note on page 178)

Interaction condition: $3V_{z,d} + 2H_d + F_{t,d} = \max F_{t,d}$

$$\frac{\max F_{t,d}}{F_{t,Rd}} < 1.0 \quad \max F_{t,d} = 3V_{z,d} + 2H_d + F_{t,d} = 3 \times 25 \text{ kN} + 2 \times 3 \text{ kN} + 30 \text{ kN} = 111 \text{ kN}$$

$$\frac{\max F_{t,d}}{F_{t,Rd,QST16}} = \frac{111 \text{ kN}}{116.8 \text{ kN}} = 0.95 < 1.0$$

Minimum end plate thickness [d] without detailed verification, using mild steel S235: Distance $b \leq 35$ mm

$$\frac{F_{c,d}}{F_{c,Rd,QST16}} \text{ or } \frac{\max F_{t,d}}{F_{t,Rd,QST16}} \begin{cases} \leq 1.0 & : 30 \text{ mm} \\ \leq 0.75 & : 25 \text{ mm} \\ \leq 0.5 & : 20 \text{ mm} \end{cases} \quad \frac{\max F_{t,d}}{F_{t,Rd,QST16}} = 0.95 < 1.0 \rightarrow d = 25 \text{ mm}$$

Schöck Isokorb®

Design configurations, type KST-QST 22 module, KST-ZQST 22 module, KST 16

2 Side elevation Steel member with end plate according to structural requirements

Plan elevation

KST-QST 22 module, KST-ZQST 22 ²⁾ module	
H_{Rd}	6 kN ³⁾
V_{Rd}	36 kN
$F_{t,Rd}, F_{c,Rd}$	225.4 kN

Interaction between $V_d, H_d, F_{t,d}$:

$$3 V_d + 2 H_d + F_{t,d} = \max F_{t,d} \leq F_{t,Rd}$$

¹⁾ Minimum end plate thicknesses [d] without detailed verification, using mild steel S235:

$\max F_{t,d} = \frac{F_{c,d}}{F_{t,Rd}} \leq 1.0$: 40 mm
≤ 0.75	: 35 mm
≤ 0.5	: 30 mm

²⁾ The Schöck Isokorb® type KST-ZQST 22 module should be used for applications in which tensile forces need to be transferred continuously into the connection and in which, at the same time, horizontal forces resulting from temperature deformation of the external steel structure are transferred into the connection. Special two-part washers provide fatigue resistance. Refer to pages 180 - 181 for the expansion joint gaps.

³⁾ Always refer to the information about expansion joints/fatigue resistance on pages 180 - 181.

Schöck Isokorb® modules, type KST-QST 22, KST-ZQST 22²⁾

3 Side elevation Steel member with end plate according to structural requirements

Plan elevation

KST 16	
H_{Rd}	6 kN ²⁾
V_{Rd}	30 kN
$F_{t,Rd}, F_{c,Rd}$	116.8 kN

¹⁾ Minimum end plate thicknesses [d] without more specific verification (Fkl.: S 235):

$a \leq 150$:	$\frac{F_{t,d}}{F_{t,Rd}} \leq 1.0$: 25 mm
	≤ 0.9 : 20 mm
$a < 150$:	30 mm

²⁾ Always refer to the information about expansion joints/fatigue resistance on pages 180 - 181.

Schöck Isokorb® type KST 16

KST

Steel-to-steel

Schöck Isokorb® type KST 22

Design configuration and example

4 Side elevation

Steel member with end plate according to structural requirements

KST 22	
H_{Rd}	6 kN ²⁾
V_{Rd}	36 kN
Z_{Rd}, D_{Rd}	225.4 kN

¹⁾ Minimum end plate thicknesses [d] without detailed verification, using mild steel S235:

$a \leq 150$: $\frac{F_{t,d}}{F_{t,Rd}} \leq 1.0$: 35 mm
 $\frac{F_{t,d}}{F_{t,Rd}} \leq 0.8$: 30 mm
 $\frac{F_{t,d}}{F_{t,Rd}} \leq 0.5$: 25 mm

$a < 150$: 40 mm

²⁾ Always refer to the information about expansion joints/fatigue resistance on pages 180 - 181.

Schöck Isokorb® type KST 22

Example of moment connections for UB 203 × 23 with KST 22

Loads: Load case 1: $V_{z,d} = 32$ kN $H_d = \pm 4$ kN $M_{y,d} = -18$ kNm
 Load case 2: $V_{z,d} = -16$ kN $H_d = \pm 4$ kN $M_{y,d} = 5$ kNm
 $a = 0.12$ m

Verifications for KST

Shear force and horizontal force

$$\frac{V_{z,d}}{V_{z,Rd}} < 1.0 \quad \frac{H_d}{H_{Rd}} < 1.0 \quad \frac{V_{z,d}}{V_{z,Rd,QST22}} = 32 \text{ kN} / 36 \text{ kN} = 0.89 < 1.0$$

$$\frac{H_d}{H_{Rd,QST22}} = 4 \text{ kN} / 6 \text{ kN} = 0.67 < 1.0$$

Moment at load case 1

$$\frac{N_{c,d}}{N_{c,Rd}} < 1.0 \quad \frac{N_{t,d}}{N_{t,Rd}} < 1.0 \quad F_{c,d} = F_{t,d} = M_{y,d} / a = 18 \text{ kNm} / 0.12 \text{ m} = 150 \text{ kN}$$

$$\frac{F_{c,d}}{F_{c,Rd,QST22}} = 150 \text{ kN} / 225.4 \text{ kN} = 0.67 < 1.0$$

$$\frac{F_{t,d}}{F_{t,Rd,ZST22}} = 150 \text{ kN} / 225.4 \text{ kN} = 0.67 < 1.0$$

Moment at load case 2 (lifting off)

$$\max N_{t,d} < N_{t,Rd} \quad F_{c,d} = F_{t,d} = M_{y,d} / a = 5 \text{ kNm} / 0.12 \text{ m} = 41.67 \text{ kN}$$

$$\max F_{t,d} = 41.67 \text{ kN} < 225.4 \text{ kN} = F_{t,Rd,QST22}$$

KST-ZST module under compressive load

(see note on page 178)

$$\max F_{c,d} < F_{t,Rd} / 3$$

$$\max F_{c,d} = M_{y,d} / a = 5 \text{ kNm} / 0.12 \text{ m} = 41.67 \text{ kN}$$

$$F_{t,Rd,ZST22} / 3 = 225.4 \text{ kN} / 3 = 75.13 \text{ kN}$$

$$\max F_{c,d,ZST22} = 41.67 \text{ kN} < 75.13 \text{ kN} = F_{t,Rd,ZST22} / 3$$

KST

Steel-to-steel

Schöck Isokorb® type KST 22

Example

KST-QST module under tensile load (see note on page 178)

Interaction condition:

$$3V_{z,d} + 2H_d + F_{t,d} = \max F_{t,d}$$

$$\max F_{t,d} = 3V_{z,d} + 2H_d + F_{t,d} = 3 \times 16 + 2 \times 4 + 41.67 = 97.67 \text{ kN}$$

$$\frac{\max F_{t,d}}{F_{t,Rd}} < 1.0$$

$$\max F_{t,d}/F_{t,Rd,ZST22} = 97.67/225.4 = 0.43 < 1.0$$

Minimum end plate thickness [d] without detailed verification, using mild steel S235: Distance b ≤ 50 mm

$$a \leq 150: \frac{F_{t,d}}{F_{t,Rd}} \begin{cases} \leq 1.0 & : 35 \text{ mm} \\ \leq 0.8 & : 30 \text{ mm} \\ \leq 0.5 & : 25 \text{ mm} \end{cases}$$

$$F_{t,d}/F_{t,Rd} = 150 \text{ kN}/225.4 \text{ kN} = 0.67$$

$$a \leq 150: \frac{F_{t,d}}{F_{t,Rd}} = 0.67 < 0.8 \rightarrow d = 30 \text{ mm}$$

$$a > 150: 40 \text{ mm}$$

Deformation due to $M_{y,d}$ (see page 179)

Buckling angle

$$\varphi = \frac{M_k}{c} \text{ [rad]}$$

$$\varphi = \frac{18/1.45^1 \times 100}{864000} = 1.4368 \times 10^{-3} \text{ [rad]}$$

$$c = 6000 \times a^2 \text{ [cm]}$$

$$c = 6000 \times 12^2 = 864000 \text{ [kNcm/rad]}$$

¹⁾ Conversion of $M_{y,d}$ into M_k
(with global safety factor $\gamma_f = 1.45$)

Notes on the example

- ▶ The information relating to the fatigue resistance of expansion joints on pages 180 - 181 must be followed.
- ▶ In the event of a short-term tensile load (e.g. from wind suction) a KST-QST module can be used instead of the KST-ZQST module in the lower connection, even if horizontal forces are introduced from temperature deformation H_d .
- ▶ The KST-ZST module can also be subjected to compressive loads of up to $1/3 F_{t,Rd}$ (see footnote 6 on page 178). If $F_{c,d} > 1/3 F_{t,Rd}$ then a KST-ZQST module must be used for the KST-ZST module.
- ▶ Greater stiffness can also be achieved with the arrangement no. 5.

Schöck Isokorb® type KST 22

Design configurations

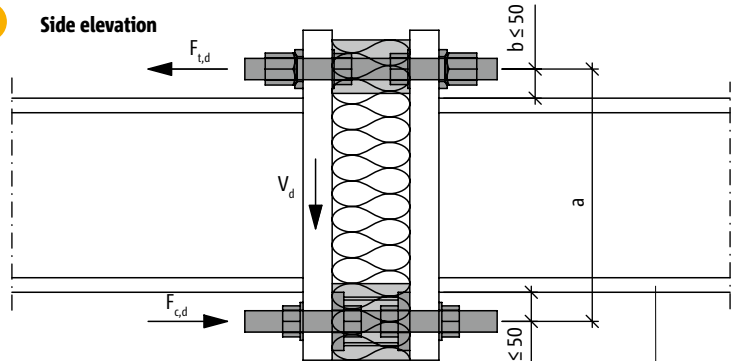
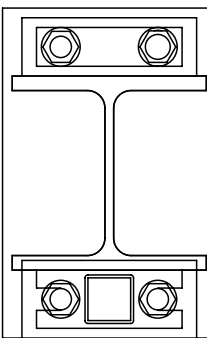
5 **Side elevation**  **Front elevation** 

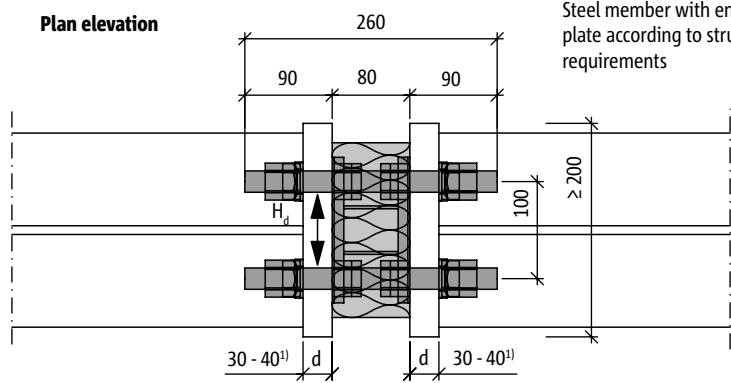
Plan elevation  Steel member with end plate according to structural requirements

KST 22	
H_{Rd}	6 kN ²⁾
V_{Rd}	36 kN
$F_{t,Rd}$, $F_{c,Rd}$	225.4 kN

¹⁾ Minimum end plate thicknesses [d] without detailed verification, using mild steel S235:
 $F_{t,d} \leq 1.0$: 40 mm
 $F_{c,d} \leq 0.75$: 35 mm
 $F_{t,Rd} \leq 0.5$: 30 mm

²⁾ Always refer to the information about expansion joints/fatigue resistance on pages 180 - 181.

Schöck Isokorb® type KST 22

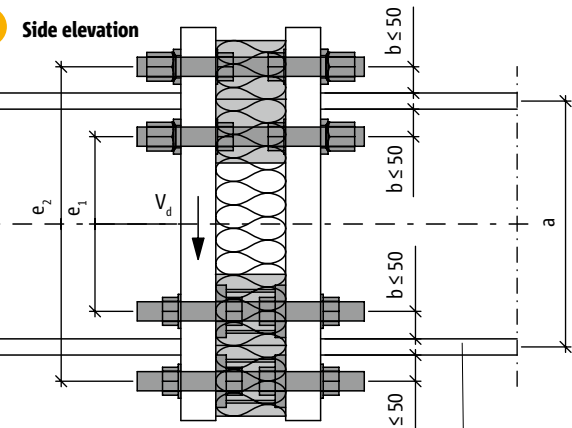
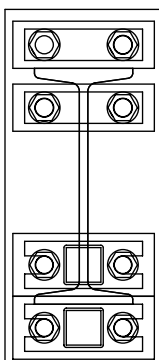
6 **Side elevation**  **Front elevation** 

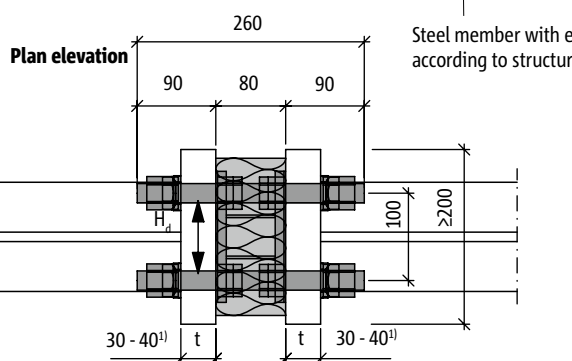
Plan elevation  Steel member with end plate according to structural requirements

$n = e_1/e_2$

$F_{t,d}$; $n \times F_{t,d}$; $F_{c,d}$; $n \times F_{c,d}$; V_d ; H_d

$F_{c,d} \downarrow \frac{V_d}{2} ; \frac{H_d}{2}$; $F_{t,d} \downarrow \frac{V_d}{2} ; \frac{H_d}{2}$

Load-bearing capacity of the individual module:

KST 22 per module	
H_{Rd}	6 kN ²⁾
V_{Rd}	36 kN
$F_{t,Rd}$, $F_{c,Rd}$	225.4 kN

¹⁾ Minimum end plate thicknesses [d] without detailed verification, using mild steel S235:
 $F_{t,d}$ per module ≤ 1.0 : 40 mm
 $F_{c,d}$ per module ≤ 0.75 : 35 mm
 $F_{t,Rd} \leq 0.5$: 30 mm

²⁾ Always refer to the information about expansion joints/fatigue resistance on pages 180 - 181.

Schöck Isokorb® for connection of members with 2 × KST 22 (2 tensile and 2 compressive shear force modules)

KST

Steel-to-steel

Schöck Isokorb® type KST 22

Design configurations

7 Side elevation

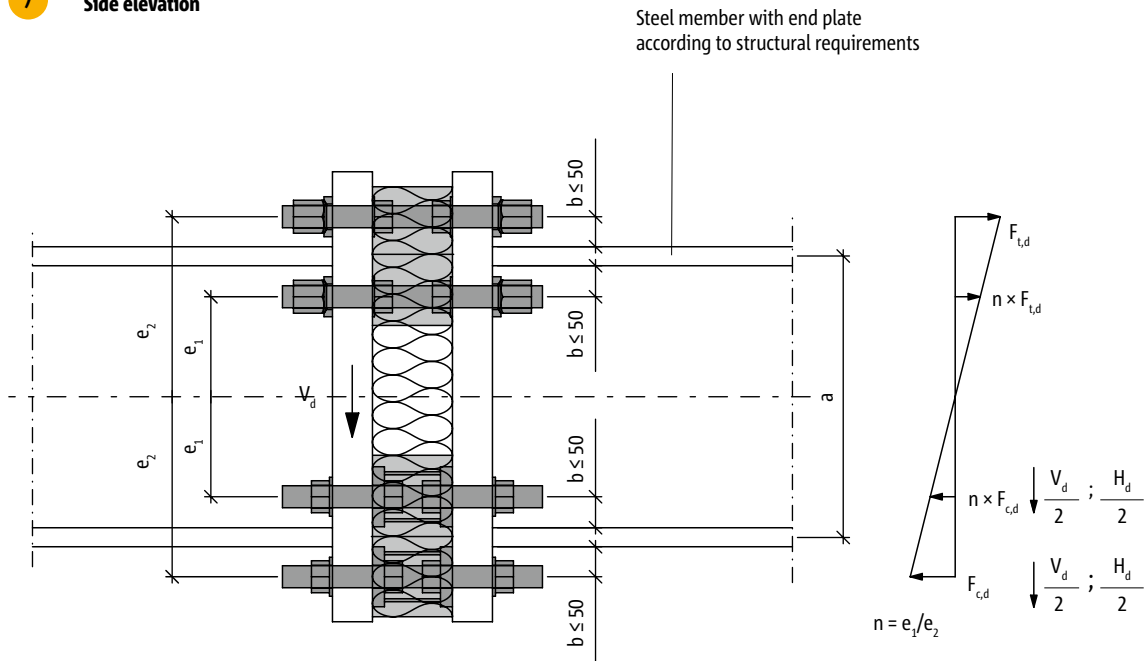

Plan elevation

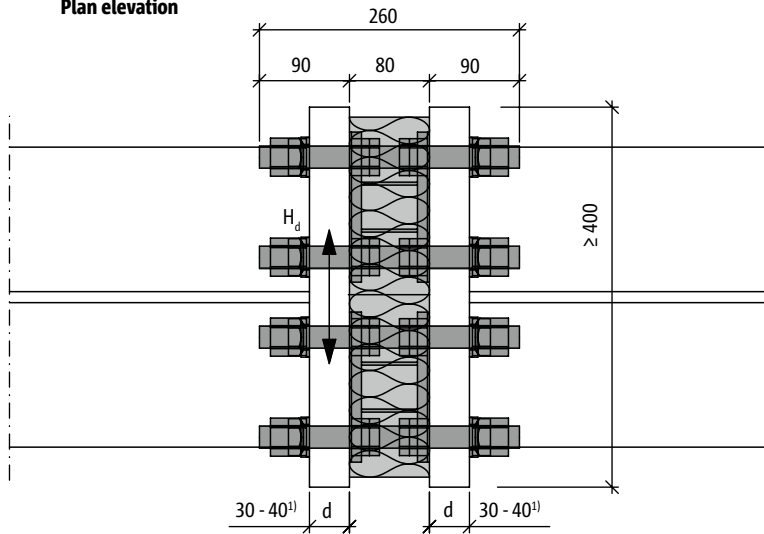

Front elevation

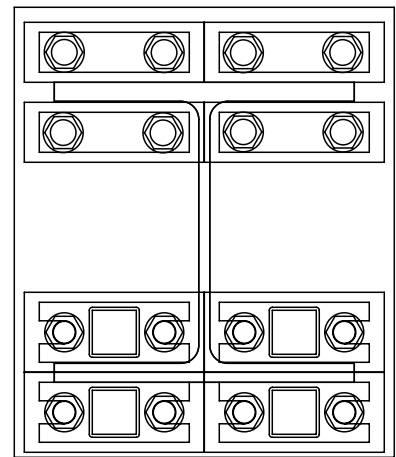

¹⁾ Minimum end plate thicknesses [d] without detailed verification, using mild steel S235:

$F_{t,d}$ per module	≤ 1.0 : 40 mm
$F_{t,Rd}$	≤ 0.75 : 35 mm
$F_{c,Rd}$	≤ 0.5 : 30 mm

²⁾ Always refer to the information about expansion joints/fatigue resistance on pages 180 - 181.

Load-bearing capacity of the individual module:

KST 22per module	
H_{Rd}	6 kN ²⁾
V_{Rd}	36 kN
$F_{t,Rd}^* F_{c,Rd}$	225.4 kN

Schöck Isokorb® type KST-QST 22 module, KST-ZQST 22 module

Design configuration

8 Side elevation

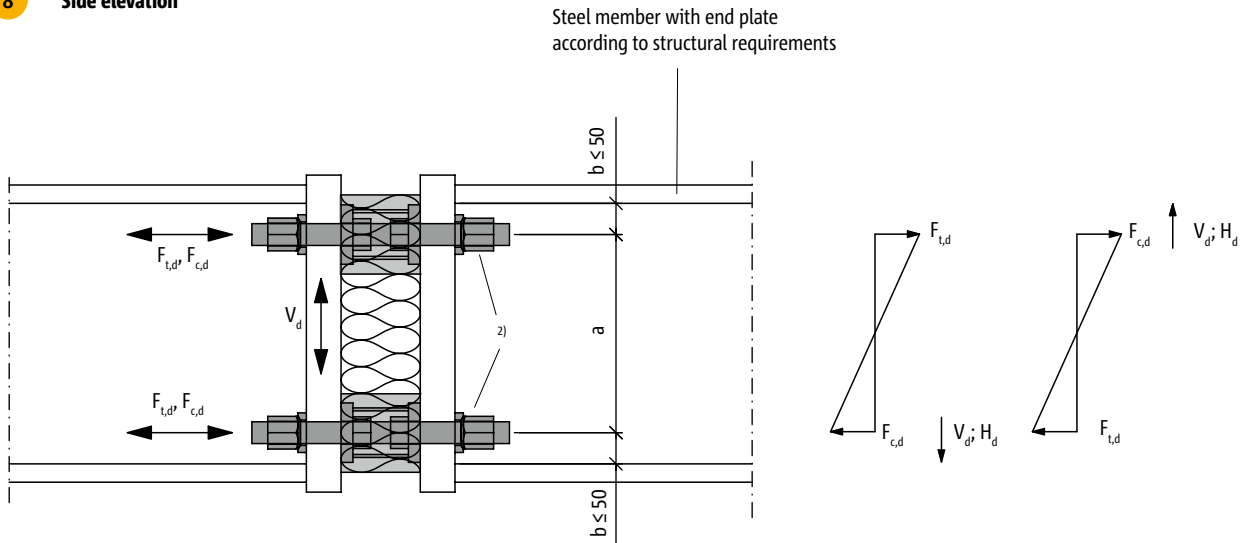

Plan elevation

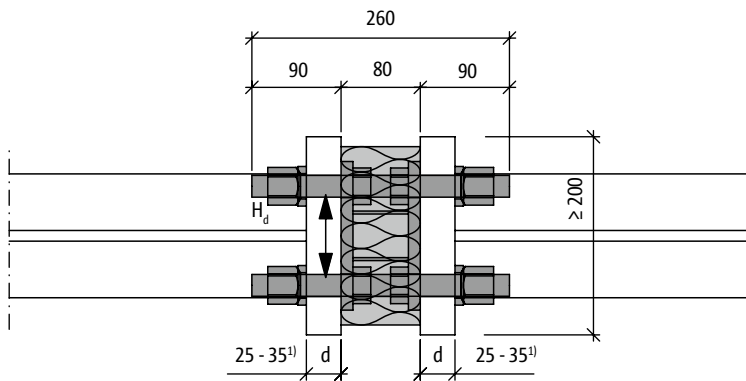

Front elevation

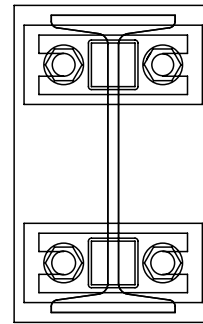

Load-bearing capacity of the individual module:

KST-QST 22 module, KST-ZQST 22 ²⁾ module	
H_{Rd}	6 kN ³⁾
V_{Rd}	36 kN
$F_{t,Rd}$ / $F_{c,Rd}$	225.4 kN

¹⁾ Minimum end plate thicknesses without detailed verification, using mild steel S235:

$$\frac{F_{t,d} \text{ per module}}{F_{t,Rd}} \leq \begin{matrix} 1.0 : 35 \text{ mm} \\ 0.8 : 30 \text{ mm} \\ 0.5 : 25 \text{ mm} \end{matrix}$$

²⁾ This variant should be used if the system needs to absorb large forces which act on alternating sides (e.g. wind loads from below onto the cantilever). The KST-ZQST module should be used in accordance with page 177 wherever primarily tensile forces (resulting from permanent loads) are transferred. The element, which is subjected only temporarily to a tensile load, can be used as a KST-QST 22 module.

³⁾ Always refer to the information about expansion joints/fatigue resistance on pages 180 - 181.

Schöck Isokorb®

Example: type KST-QST 22 module, KST-ZQST 22 module

Example of moment connections for UB 203 × 23 for lifting-off forces with 2 × KST-ZQST 22 modules

Loads:	Load case 1:	$V_{z,d} = 32 \text{ kN}$	$H_d = \pm 5 \text{ kN}$	$M_{y,d} = -18 \text{ kNm}$
	Load case 2:	$V_{z,d} = -34 \text{ kN}$	$H_d = \pm 5 \text{ kN}$	$M_{y,d} = 20 \text{ kNm}$
	$a = 0.12 \text{ m}$			

Verifications for KST-ZQST 22 module

Shear force and horizontal force

$$\frac{V_{z,d}}{V_{z,Rd}} < 1.0 \quad \frac{H_d}{H_{Rd}} < 1.0 \quad \frac{V_{z,d}}{V_{z,Rd,ZQST22}} = 32 \text{ kN}/36 \text{ kN} = 0.89 < 1.0$$

$$\frac{H_d}{H_{Rd,ZQST22}} = 5 \text{ kN}/6 \text{ kN} = 0.83 < 1.0$$

Moment at load case 1

$$\frac{F_{c,d}}{F_{c,Rd}} < 1.0 \quad \frac{F_{t,d}}{F_{t,Rd}} < 1.0 \quad F_{c,d} = F_{t,d} = M_{y,d}/a = 18 \text{ kNm}/0.12 \text{ m} = 150 \text{ kN}$$

$$\frac{F_{c,d}}{F_{c,Rd,ZQST22}} = 150 \text{ kN}/225.4 \text{ kN} = 0.67 < 1.0$$

$$\frac{F_{t,d}}{F_{t,Rd,ZQST22}} = 150 \text{ kN}/225.4 \text{ kN} = 0.67 < 1.0$$

Shear force and moment at load case 2 (lifting off)

$$\frac{V_{z,d}}{V_{z,Rd}} < 1.0 \quad \frac{V_{z,d}}{V_{z,Rd,ZQST22}} = 34 \text{ kN}/36 \text{ kN} = 0.94 < 1.0$$

$$\frac{F_{c,d}}{F_{c,Rd}} < 1.0 \quad \frac{F_{t,d}}{F_{t,Rd}} < 1.0 \quad F_{c,d} = F_{t,d} = M_{y,d}/a = 20 \text{ kNm}/0.12 \text{ m} = 166.67 \text{ kN}$$

$$\frac{F_{c,d}}{F_{c,Rd,ZQST22}} = 166.67 \text{ kN}/225.4 \text{ kN} = 0.74 < 1.0$$

$$\frac{F_{t,d}}{F_{t,Rd,ZQST22}} = 166.67 \text{ kN}/225.4 \text{ kN} = 0.74 < 1.0$$

Minimum end plate thickness [d] without detailed verification, using mild steel S235: Distance $b \leq 50 \text{ mm}$

$$\frac{\max F_{t,d}}{F_{t,Rd,QST22}} \begin{cases} \leq 1.0 & : 35 \text{ mm} \\ \leq 0.8 & : 30 \text{ mm} \\ \leq 0.5 & : 25 \text{ mm} \end{cases} \quad \frac{F_{t,d}}{F_{t,Rd}} = 0,74 < 0.8 \rightarrow d = 30 \text{ mm}$$

Deformation due to $M_{y,d}$ see page 179

Notes

- ▶ As the compressive force for the KST-ZQST module will exceed 1/3 of the permitted tensile force, one KST-ZST 22 module in the upper tensile area structurally is not sufficient; furthermore, the interaction cannot be satisfied for the KST-QST module under tensile loads.

$$(F_{c,d} = 166.67 \geq \frac{225.4}{3} = F_{t,Rd})$$
- ▶ In the lower area, tensile forces due to the wind will only occur for a limited time. Accordingly, a single KST-QST module would offer sufficient fatigue resistance. However, in order to prevent mix-ups, a symmetrical connection with 2 × KST-ZQST modules is recommended.
- ▶ As it cannot be ensured that the KST-QST modules/KST-ZQST modules establish a similarly large resistance to the dissipation of shear forces at the same time, only the module which is located in the compressive area must be used to dissipate shear forces.

KST

Steel-to-steel

Schöck Isokorb® type KST-QST 22 module, KST-ZQST 22 module

Design configuration

9 Side elevation

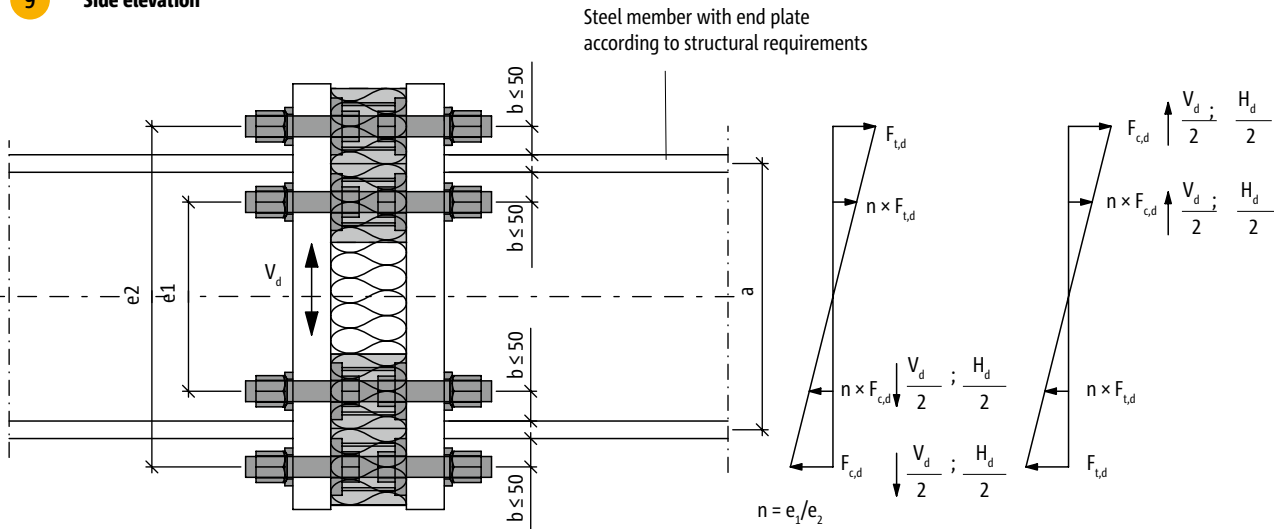

Plan elevation

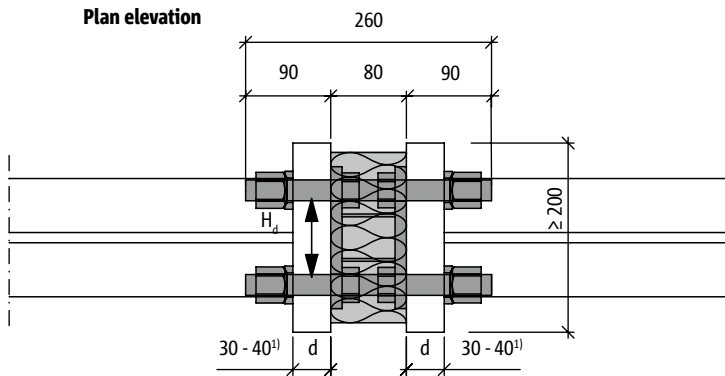

Front elevation

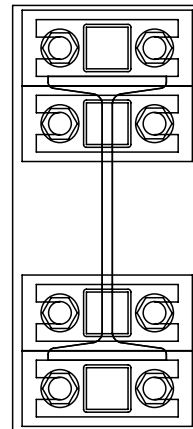

Load-bearing capacity of the individual module:

per KST-QST 22 module, KST-ZQST 22 ²⁾ module	
H_{Rd}	6 kN ³⁾
V_{Rd}	36 kN
$F_{t,Rd}$, $F_{c,Rd}$	225.4 kN

¹⁾ Minimum end plate thicknesses [d] without detailed verification, using mild steel S235:

$$\frac{F_{t,d} \text{ per module}}{F_{t,Rd}} \leq \begin{matrix} 1.0 & : 40 \text{ mm} \\ 0.75 & : 35 \text{ mm} \\ 0.5 & : 30 \text{ mm} \end{matrix}$$

²⁾ This variant should be used if the system needs to absorb large forces which act on alternating sides (e.g. wind loads from below onto the cantilever). The KST-ZQST module should be used in accordance with page 177 wherever primarily tensile forces (resulting from permanent loads) are transferred. The element, which is subjected only temporarily to a tensile load, can be used as a KST-QST 22 module.

³⁾ Always refer to the information about expansion joints/fatigue resistance on pages 180 - 181.

Schöck Isokorb®

Example: type KST-QST 22 module, KST-ZQST 22 module

Example of moment connections for UB 356 × 33 for lifting-off forces with 4 × KST-ZQST 22 modules

Loads:	Load case 1:	$V_{z,d} = 55 \text{ kN}$	$M_{y,d} = -130 \text{ kNm}$	$e_1 = 0.25 \text{ m}$
	Load case 2:	$V_{z,d} = -40 \text{ kN}$	$M_{y,d} = 80 \text{ kNm}$	$e_2 = 0.45 \text{ m}$

Verifications for KST-ZQST 22 module

Shear force

$$\frac{V_{z,d}}{V_{z,Rd}} < 1.0$$

$$\begin{aligned} V_{z,Rd,ZQST22} &= 2 \times 36 \text{ kN} = 72 \text{ kN} \\ V_{z,d}/V_{z,Rd,ZQST22} &= 55 \text{ kN}/72 \text{ kN} = 0.76 < 1.0 \end{aligned}$$

Moment at load case 1

$$F_{c,d} = F_{t,d} = M_{y,d}/e_2 + \left(\frac{e_1}{e_2} \times e_1 \right)$$

$$\begin{aligned} F_{c,d} = F_{t,d} &= 130 \text{ kNm}/(0.45 \text{ m} + (0.25 \text{ m}/0.45 \text{ m} \times 0.25 \text{ m})) \\ F_{c,d} = F_{t,d} &= 220.8 \text{ kN} \end{aligned}$$

$$\frac{F_{c,d}}{F_{c,Rd}} < 1.0 \quad \frac{F_{t,d}}{F_{t,Rd}} < 1.0$$

$$\begin{aligned} F_{c,d}/F_{c,Rd,ZQST22} &= 220.8 \text{ kN}/225.4 \text{ kN} = 0.98 < 1.0 \\ F_{t,d}/F_{t,Rd,ZQST22} &= 220.8 \text{ kN}/225.4 \text{ kN} = 0.98 < 1.0 \end{aligned}$$

Shear force and moment at load case 2 (lifting off)

$$\frac{V_{z,d}}{V_{z,Rd}} < 1.0$$

$$\begin{aligned} V_{z,Rd,ZQST22} &= 2 \times 36 \text{ kN} = 72 \text{ kN} \\ V_{z,d}/V_{z,Rd,ZQST22} &= 40 \text{ kN}/72 \text{ kN} = 0.55 < 1.0 \end{aligned}$$

$$F_{c,d} = F_{t,d} = M_{y,d}/e_2 + \left(\frac{e_1}{e_2} \times e_1 \right)$$

$$\begin{aligned} F_{c,d} = F_{t,d} &= 80 \text{ kNm}/(0.45 \text{ m} + (0.25 \text{ m}/0.45 \text{ m} \times 0.25 \text{ m})) \\ F_{c,d} = F_{t,d} &= 135.8 \text{ kN} \end{aligned}$$

$$\frac{F_{c,d}}{F_{c,Rd}} < 1.0 \quad \frac{F_{t,d}}{F_{t,Rd}} < 1.0$$

$$\begin{aligned} F_{c,d}/F_{c,Rd,ZQST22} &= 135.8 \text{ kN}/225.4 \text{ kN} = 0.6 < 1.0 \\ F_{t,d}/F_{t,Rd,ZQST22} &= 135.8 \text{ kN}/225.4 \text{ kN} = 0.6 < 1.0 \end{aligned}$$

Minimum end plate thickness [d] without detailed verification, using mild steel S235: Distance $b \leq 50 \text{ mm}$

$$\frac{\max F_{t,d}}{F_{t,Rd,QST22}} \begin{cases} \leq 1.0 & : 40 \text{ mm} \\ \leq 0.8 & : 35 \text{ mm} \\ \leq 0.5 & : 30 \text{ mm} \end{cases}$$

$$\frac{F_{t,d}}{F_{t,Rd}} = 0.98 \leq 1.0 \rightarrow d = 40 \text{ mm}$$

Deformation due to $M_{y,d}$ see page 179

Notes

- As the compressive force for the KST-ZQST module will exceed 1/3 of the permitted tensile force, one KST-ZST 22 module in the upper tensile area structurally is not sufficient; furthermore, the interaction cannot be satisfied for the KST-QST module under tensile loads.

$$(F_{c,d} = 166.67 \geq \frac{225.4}{8} = F_{t,Rd})$$

- In the lower area, tensile forces due to the wind will only occur for a limited time. Accordingly, a single KST-QST module would offer sufficient fatigue resistance. However, in order to prevent mix-ups, we recommend a symmetrical connection with 4 × KST-ZQST modules.
- As it cannot be ensured that the KST-QST modules/KST-ZQST modules establish a similarly large resistance to the dissipation of shear forces at the same time, only the module which is located in the compressive area must be used to dissipate shear forces.

KST

Steel-to-steel

Schöck Isokorb® type KST-QST 22 module, KST-ZQST 22 module

Design configuration

10 Side elevation

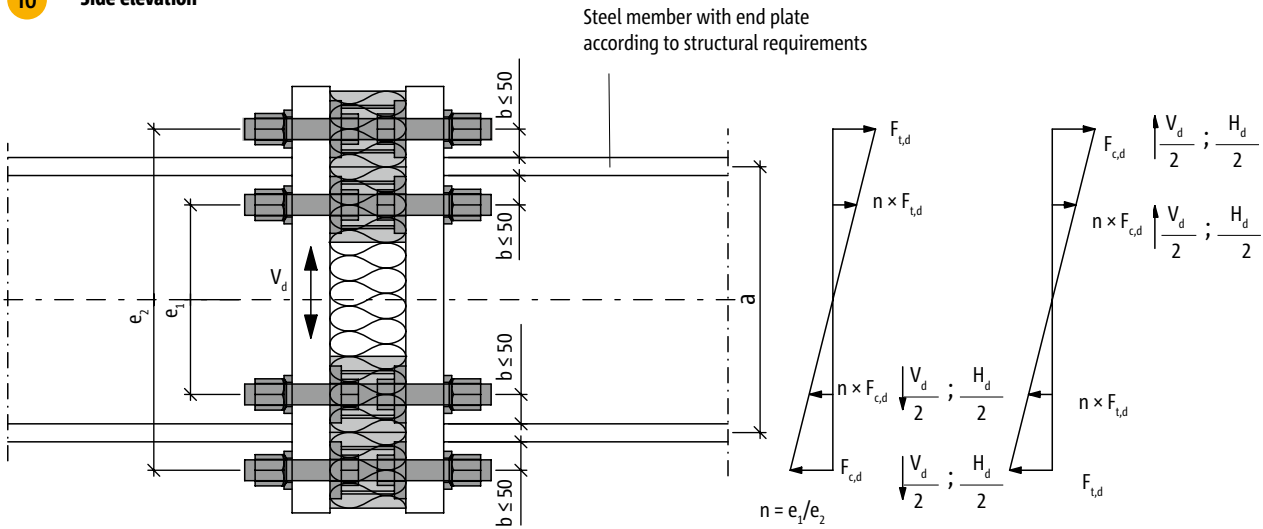

Plan elevation

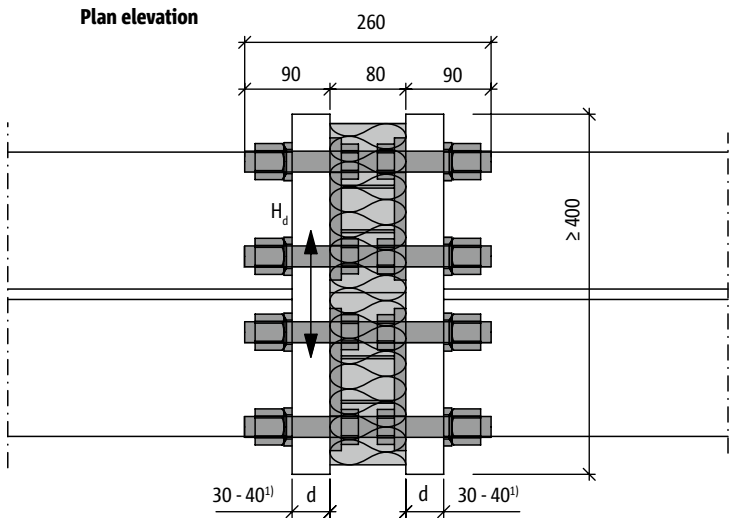

Front elevation

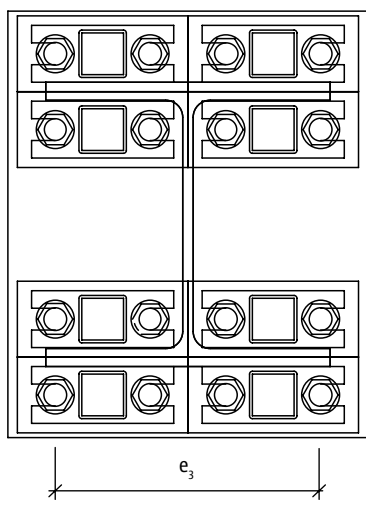

Load-bearing capacity of the individual module:

per KST-QST 22 module, KST-ZQST 22 ²⁾ module	
H_{Rd}	6 kN ³⁾
V_{Rd}	36 kN
$F_{t,Rd}$, $F_{c,Rd}$	225.4 kN

¹⁾ Minimum end plate thicknesses [d] without detailed verification, using mild steel S235:

$\frac{F_{t,d}}{F_{t,Rd}}$ per module	≤ 1.0	: 40 mm
	≤ 0.75	: 35 mm
	≤ 0.5	: 30 mm

²⁾ This variant should be used if the system needs to absorb large forces which act on alternating sides (e.g. wind loads from below onto the cantilever). The KST-ZQST module should be used in accordance with page 177 wherever primarily tensile forces (resulting from permanent loads) are transferred. The element, which is subjected only temporarily to a tensile load, can be used as a KST-QST 22 module.

³⁾ Always refer to the information about expansion joints/fatigue resistance on pages 180 - 181.

Schöck Isokorb®

Example: type KST-QST 22 module, KST-ZQST 22 module

Example: Moment connection for HEA 360 with 4 × KST-ZQST 22 modules

Loads:

Load case 1 (status during usage): $V_{z,d} = 126 \text{ kN}$ $H_d = \pm 20 \text{ kN}$ $M_{y,d} = -236 \text{ kNm}$
 Load case 2 (assembly): $V_{z,d} = -96 \text{ kN}$ $M_{y,d} = 166 \text{ kNm}$ $M_{z,d} = \pm 22 \text{ kNm}$ $F_{x,c,d} = 160 \text{ kNm}$

$e_1 = 0,215 \text{ m}$
 $e_2 = 0,450 \text{ m}$
 $e_3 = 0.280 \text{ m}$ (axis separation of the outer row of bolts)

Verification of the load case “status during usage”:

Shear force and horizontal force at load case 1

$$\frac{V_{z,d}}{V_{z,Rd}} < 1.0$$

$$V_{z,Rd,QST22} = 4 \times 36 \text{ kN} = 144 \text{ kN}$$

$$V_{z,d}/V_{z,Rd,QST22} = 126 \text{ kN}/144 \text{ kN} = 0.88 < 1.0$$

$$H_{Rd,QST22} = 4 \times 6 \text{ kN} = 24 \text{ kN}$$

$$H_d/H_{Rd,QST22} = 20 \text{ kN}/24 \text{ kN} = 0.83 < 1.0$$

Moment at load case 1

$$M_{y,d} = 2 \times F_{t,Rd} \times e_2 + 2 \times \frac{e_1}{e_2} \times N_{t,Rd} \times e_1$$

$$F_{t,Rd,QST22} = \frac{M_{y,d}}{2 \times e_2 + 2 \times \frac{e_1}{e_2} \times e_1} = \frac{236 \text{ kNm}}{2 \times 0.45 \text{ m} + 2 \times \frac{0.215 \text{ m}}{0.45 \text{ m}} \times 0.215 \text{ m}} = 213.5 \text{ kN}$$

$$\frac{F_{c,d}}{F_{c,Rd}} < 1.0 \quad \frac{F_{t,d}}{F_{t,Rd}} < 1.0$$

$$F_{c,d}/F_{c,Rd,QST22} = 213.5 \text{ kN}/225.4 \text{ kN} = 0.95 < 1.0$$

$$F_{t,d}/F_{t,Rd,QST22} = 213.5 \text{ kN}/225.4 \text{ kN} = 0.95 < 1.0$$

Minimum end plate thickness without detailed verification, using mild steel S235: Distance $b \leq 50 \text{ mm}$

$$\frac{\max F_{t,d}}{F_{t,Rd,QST22}} \begin{cases} \leq 1.0 & : 40 \text{ mm} \\ \leq 0.8 & : 35 \text{ mm} \\ \leq 0.5 & : 30 \text{ mm} \end{cases}$$

$$\frac{F_{t,d}}{F_{t,Rd}} = 0.95 < 1.0 \rightarrow d = 40 \text{ mm}$$

Deformation due to $M_{y,d}$ (see page 179)

Buckling angle

$$\varphi = \frac{M_k}{c} \text{ [rad]}$$

$$\varphi = \frac{236/1.45 \times 100}{25.5336^{06}} \text{ [rad]}$$

$$c = 24\,000 \times a^2$$

$$c = 24\,000 \times \left(\frac{(21.5 \text{ cm} + 45 \text{ cm})}{2} \right)^2 = 26.5335 \times 10^6 \text{ [kNcm/rad]}$$

KST

Steel-to-steel

Loading combination during assembly:

Shear force at load case 2

$$\frac{V_{z,d}}{V_{z,Rd}} < 1.0$$

$$\begin{aligned} V_{z,Rd,QST22} &= 4 \times 36 \text{ kN} = 144 \text{ kN} \\ V_{z,d}/V_{z,Rd,QST22} &= 96 \text{ kN}/144 \text{ kN} = 0.66 < 1.0 \end{aligned}$$

Moment at load case 2 (lifting off)

$$M_{y,d} = 2 \times D_d \times e_2 + 2 \times \frac{e_1}{e_2} \times D_d \times e_1$$

$$M_{z,d} = 2 \times D_d \times e_3$$

Verification of the bolts under the highest loads for compressive loads from bi-axial bending¹⁾

$$\frac{F_{c,d}}{F_{c,Rd}} < 1.0$$

$$F_{c,d} = \frac{M_{y,d}}{2 \times e_2 + 2 \times \frac{e_1}{e_2} \times e_1} + \frac{M_{z,d}}{2^1) \times e_3} + \frac{F_{c,d}}{8^2)}$$

$$F_{c,d} = \frac{166 \text{ KNm}}{2 \times 0.45 \text{ m} + 2 \times \frac{0.215 \text{ m}}{0.450 \text{ m}} \times 0.215 \text{ m}} + \frac{22 \text{ KNm}}{2 \times 0.28 \text{ m}} + \frac{160 \text{ KNm}}{8}$$

$$F_{c,d} = 150.17 \text{ KN} + 39.29 \text{ KN} + 20 \text{ KN}$$

$$F_{c,d}/F_{c,Rd,QST22} = 209.46 \text{ KN}/225.4 \text{ KN} = 0.93 < 1.0$$

KST

¹⁾ Conservatively, only the external bolts are considered as being load-bearing. The calculations are performed with just 2 bolts, as $F_{c,d}$ relates to 1 module.

²⁾ Number of modules subjected to a compressive load due to normal force $F_{x,c,d}$.

Schöck Isokorb® type KST

End plate dimensioning

Example - end plate protruding

Calculation of max. bolt force: $\frac{F_{t,max,d}}{2} = F_{t,max,d}$ per bolt

Max. moment in the end plate:

$$M_d = F_{t,max,d,bolt} \times a_l = [\text{kNmm}]$$

$$W = d^2 \times b_{ef}/6 = [\text{mm}^2] \text{ with}$$

$$b_{ef} = \min(b_1; b_2/2; b_3/2)$$

d = thickness of end plate

c = diameter of U-washer

c (KST 16) = 30 mm,

c (KST 22) = 39 mm

$$b_1 = 2 \times a_l + c \text{ [mm]}$$

b_2 = member width or width of end plate [mm]

$$b_3 = 2 \times a_l + c + 100 \text{ [mm]}$$

$$M_{R,d} = W \times f_{y,k}/1.1 = [\text{kNmm}]$$

$$M_d/M_{R,d} \leq 1.0$$

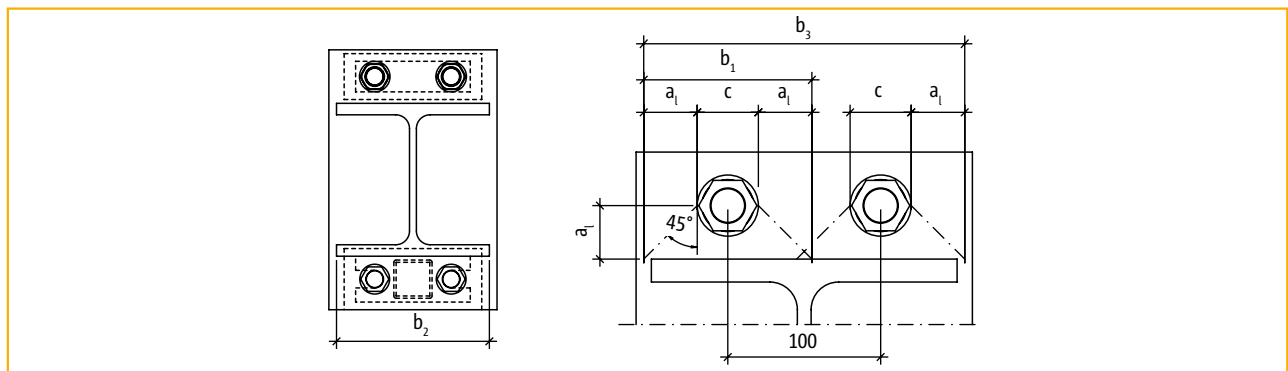

Schöck Isokorb® type KST 22 dimensioning of the end plate

Example - end plate flush

Max. tensile or compressive force per module: $F_{t,d} = F_{c,d}$

Max. moment in the end plate: $M_d = F_{t,d} \times (a_l + \frac{t}{2})$

$W = d^2 \times b_{ef}/6$ with

$$b_{ef} = b - 2 \times f$$

d = thickness of end plate

f = diameter of bore

f (KST 16) = 18 mm

f (KST 22) = 24 mm

b = width of end plate

$$M_{R,d} = W \times f_{y,k}/1.1$$

$$M_d/M_{R,d} \leq 1.0$$

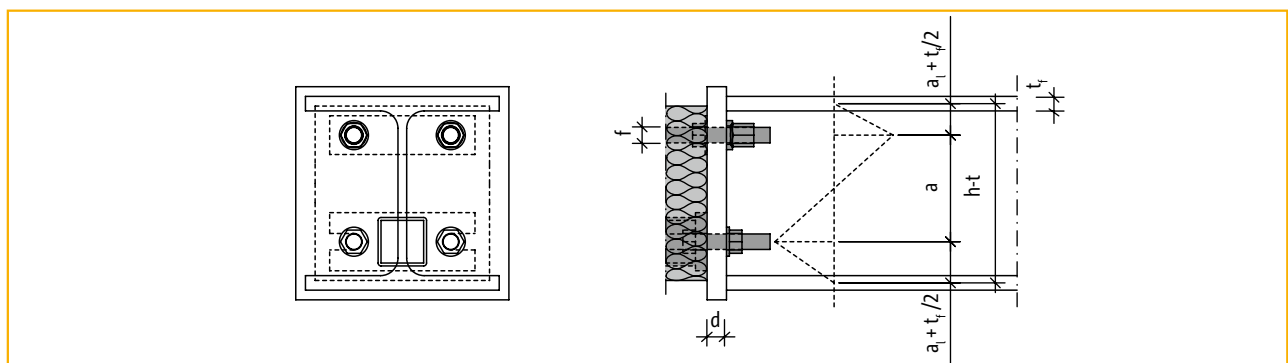

Schöck Isokorb® type KST 16 dimensioning of the end plate

Schöck Isokorb® type KST

Method statement

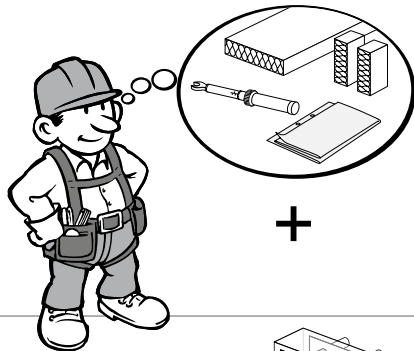

+

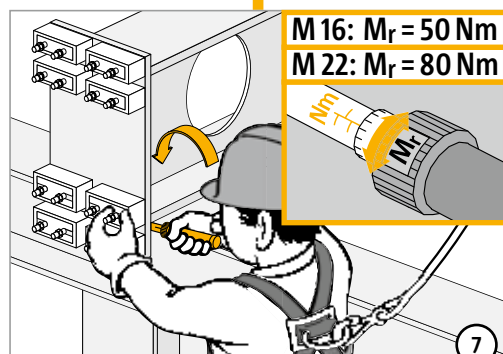
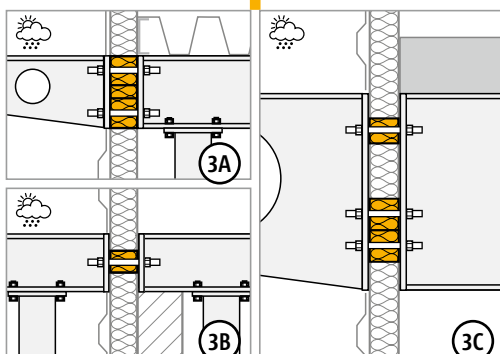
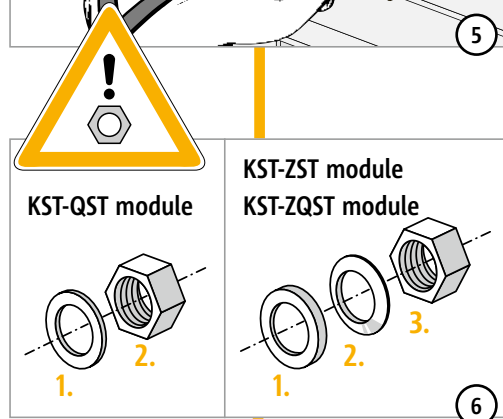
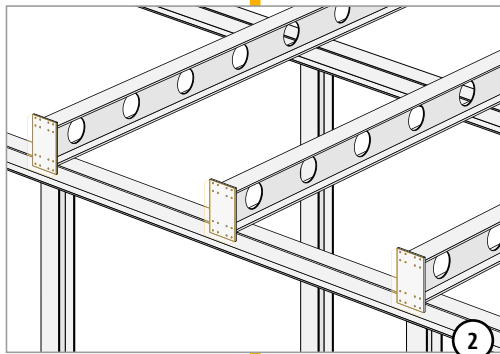
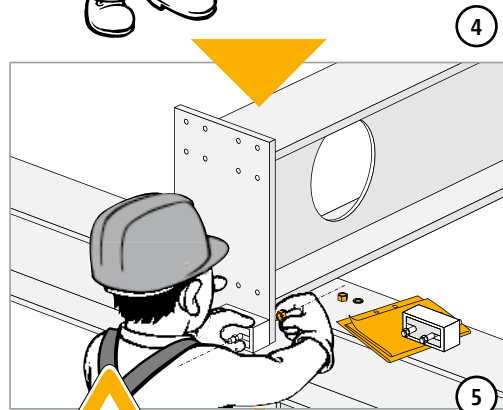
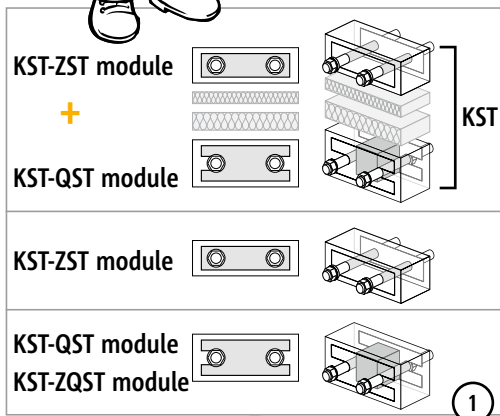

KST

Steel-to-steel

Schöck Isokorb® type KST

Method statement

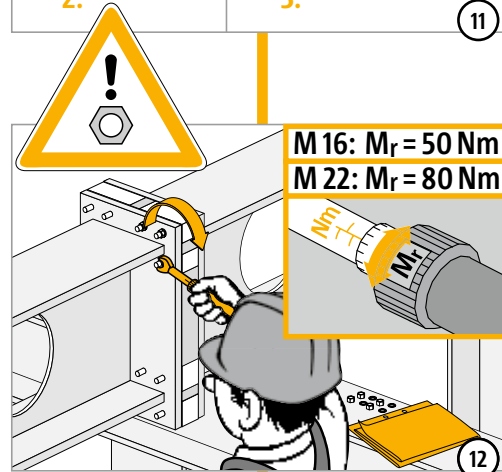
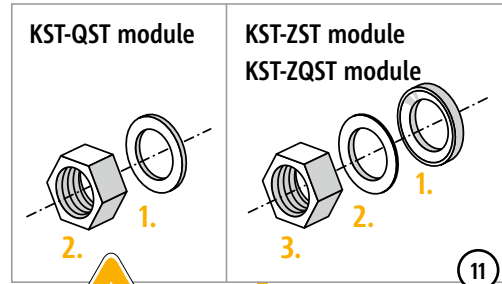
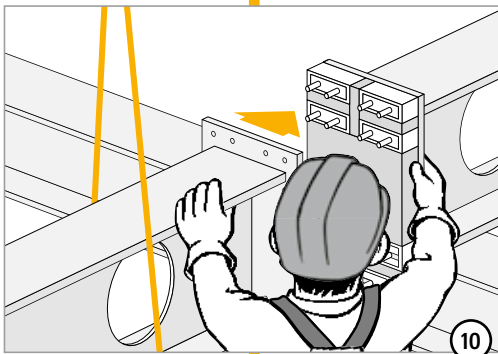
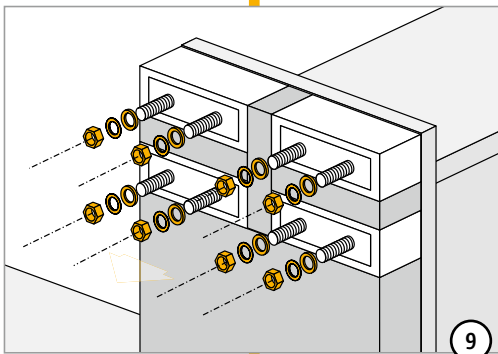
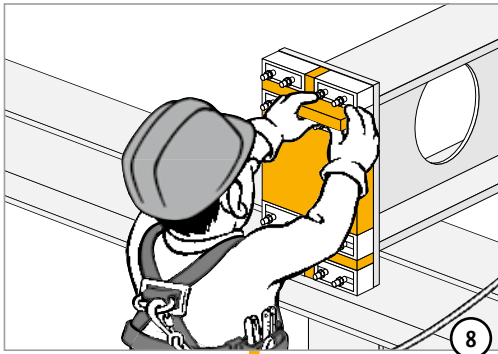

KST

Steel-to-steel

Schöck Isokorb® type KST

Constructions details

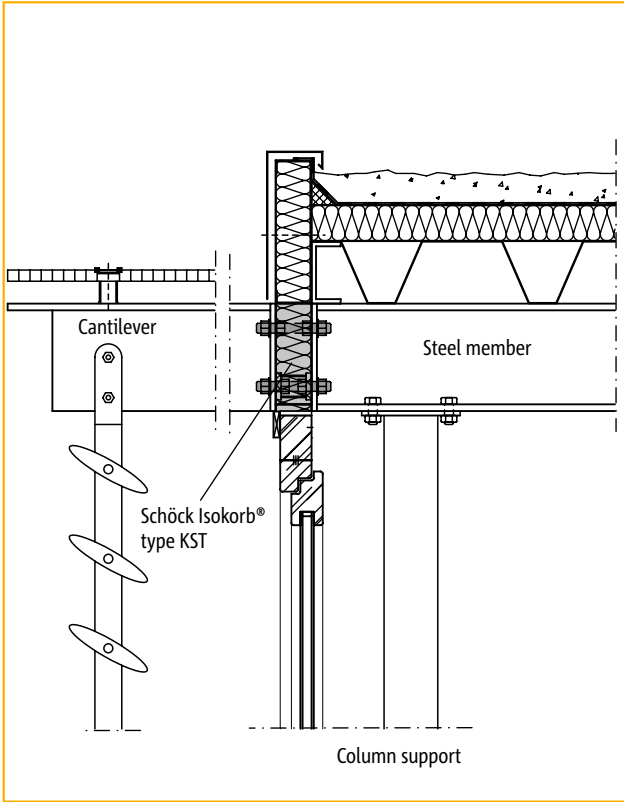

Provision of adjustable shading

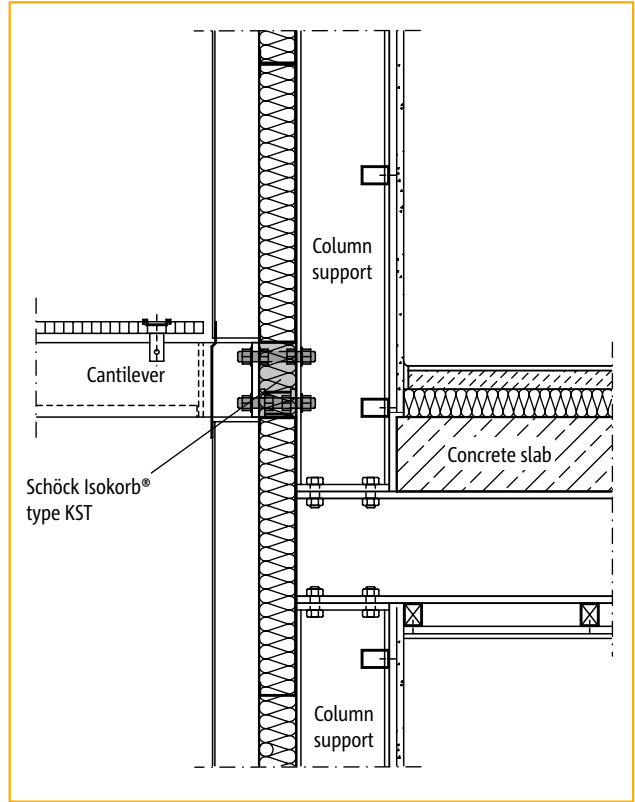

Cantilevered canopy construction to column

KST

Steel-to-steel

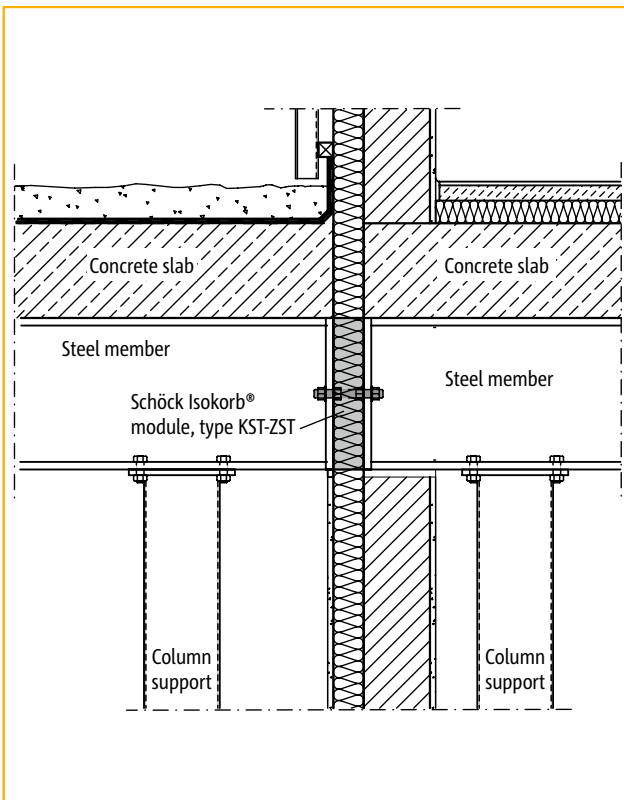

Thermally insulated building transition

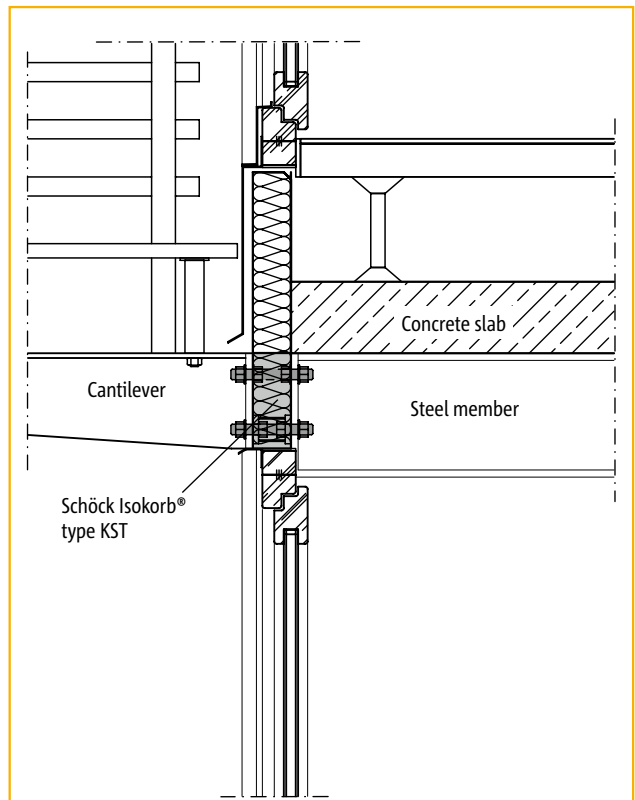

Façade balcony connection

Schöck Isokorb® KST, QST, ZST, ZQST module

Check list



- Have the member forces on the Isokorb® connection been determined at the design level?
- Will the Isokorb® element be used under primarily static loads (see page 179)?
- Are temperature deformations assigned directly to the Isokorb® connection? Expansion joint spacing (see pages 180 - 181)?
- Will the Isokorb® connection be exposed to an environment with a high chlorine content (e.g. inside indoor swimming pools) (see page 170)?
- Is there a fire safety requirement for the overall load-bearing structure/Isokorb® (see page 170)?
- Selection and calculation of the Isokorb® elements (refer also to pages 174 - 177 and the examples on pages 182 - 194)
 - Are the selected modules adequately dimensioned - refer to the “Design and calculation table” on page 178?
 - Have wind loads with a slight lift-off effect been assigned to the KST connection (see page 178⁶⁾)?
 - Is the interaction relationship $3 \times V_z + 2 \times H_y + Z_x = \max Z_d \leq Z_{x,Rd}$ satisfied for the KST-QST module and KST-ZQST module under tensile loads with simultaneous shear loads (see page 178³⁾)?
 - Have the KST-QST modules and KST-ZQST modules been located in the compression area in order to transfer shear forces (refer to example 8 on pages 188 - 189)?
- End plate calculation without more detailed verification (see pages 182 - 192):
Are the requirements in terms of maximum bolt distances to the flange and minimum head plate width satisfied (refer to examples 1 - 10 on pages 182 - 194)?
Front plate calculation with detailed verification: see page 195
- Did the deformation calculations for the overall structure take into account the deformation due to M_k in the Isokorb® connection (see page 179)?
- Are the individual modules clearly marked in the implementation plan and works plan so that there is no risk of their being interchanged.
- Have the tightening torques for the screwed connections been marked in the implementation plan (refer to page 196 - 197)? The nuts should be tightened spanner-tight without planned preload; the following tightening torques apply:

KST 16 (bolt ϕ 16): $M_r = 50 \text{ Nm}$
KST 22 (bolt ϕ 22): $M_r = 80 \text{ Nm}$

KST

Steel-to-steel

The Schöck Isokorb® XT

with 120 mm insulating element thickness

- 30 % more thermal insulation¹⁾
- 50 % more impact sound insulation²⁾

As inventor and innovator in the area of thermal bridges and cantilever construction elements Schöck continuously redefines the state of the art. We therefore adapted the Schöck Isokorb® to the ever increasing demands for thermal insulation and sound protection, so that it already meets tomorrow's demands today. This means the new Schöck Isokorb® XT will also make a particularly effective contribution to consistent energy savings and impact sound insulation in the future. The Schöck Isokorb® XT therefore provides an efficient thermal insulation element with increased impact sound protection.



Optimised shear force bars

The angle of the shear force bars within the insulating element is lower compared with the 80 mm thick Schöck Isokorb®, but maintain the same load-bearing capacity. This makes a major contribution to improving impact sound insulation.



50% thicker insulating element

The matching insulating element thickness contributes not only to improved thermal conductivity and increased impact sound protection but also to a thermal insulation layer which is as uniform and continuous as possible.

+50%

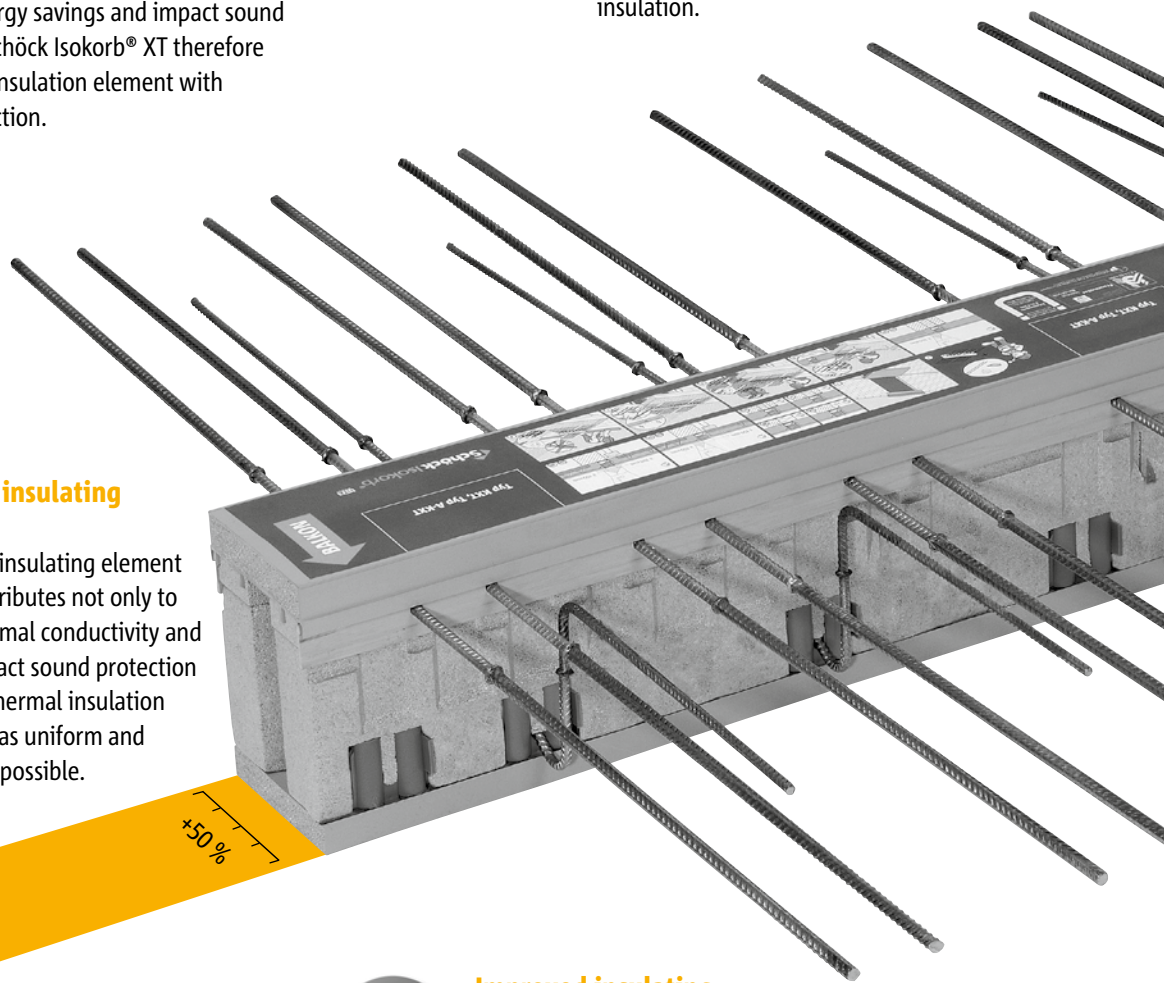

Improved insulating material

The insulating material in the new Schöck Isokorb® XT is made of Neopor^{®3)}, a polystyrene material with a silver grey colour, caused by the addition of graphite. This results in a further reduction of thermal conductivity compared with conventional polystyrene ($\lambda = 0.032 \text{ W}/(\text{m} \times \text{K})$).



¹⁾ As an average in comparison to the corresponding Isokorb® types with a thickness of 80 mm with regard to equivalent R_{20}

²⁾ In comparison with the corresponding Schöck Isokorb® types with a thickness of 80 mm and height of 180 mm with regard to $\Delta L_{n,v,w}$

³⁾ Neopor® is a registered brand of BASF

XT extra thermal break extra impact sound protection

WNR
1.4362

Higher-grade stainless steel

The tensile strength of the stainless steel used for the tension bars ($\lambda = 15 \text{ W}/(\text{m} \times \text{K})$) in the insulating element area has been improved. This allows the diameter of the bars to be reduced while still maintaining the load-bearing capacity. This in turn reduces the cross-section of heat conduction, further improving the thermal insulation performance of the Schöck Isokorb® XT.

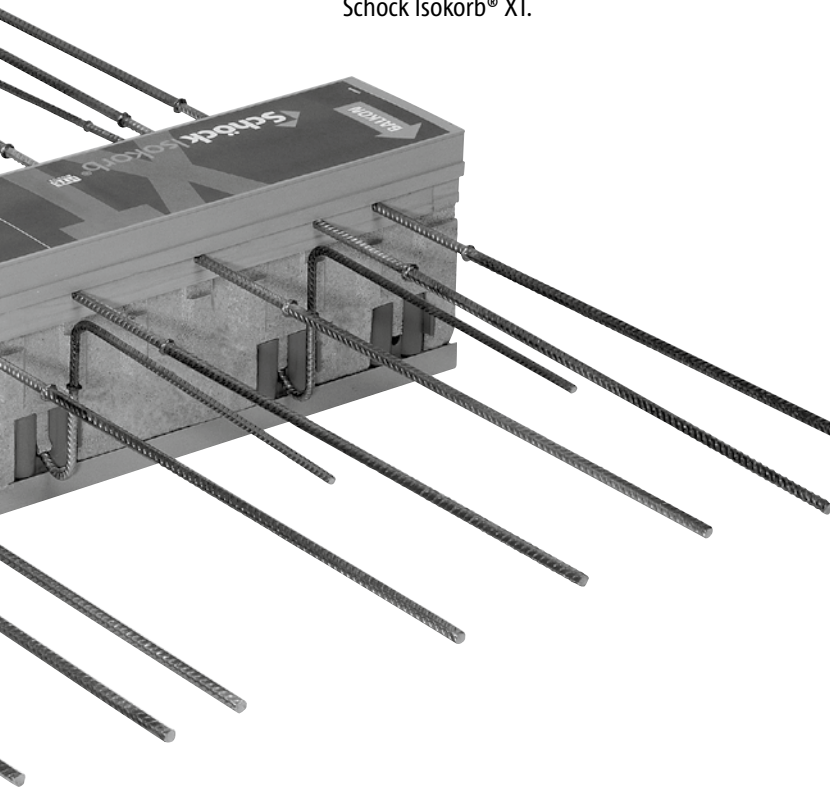

HTE
MODUL

Optimised pressure module

Schöck has further developed the core of the Isokorb® XT, the multipatented HTE module ($\lambda = 0.08 \text{ W}/(\text{m} \times \text{K})$). With identical cross-section and despite the modified insulating element thickness of 120 mm and an optimised composition, the module made from highdensity micro-fibre reinforced concrete with Kronolith⁵⁾ guarantees the high thermal insulation of the Schöck Isokorb® XT. It therefore provides an unsurpassed combination of high load-bearing capacity and optimum thermal conductivity.

THE ADVANTAGES FOR YOU AS A PLANNER:



Approved by the Passive House Institute⁴⁾

Thanks to its 30% extra thermal insulation¹⁾ even passive houses can be constructed with free cantilever balconies without a problem. The Schöck Isokorb® XT is approved as a „minimal thermal bridge design“.

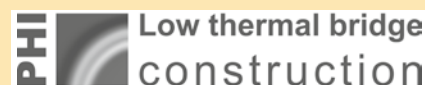

50 % better impact sound insulation²⁾

The Schöck Isokorb® XT significantly reduces the transfer of impact sound from covered balconies and balconies into the building. In addition, in many cases further measures such as floating flooring are unnecessary.



Optimised insulation thickness

The increased thickness of the insulating element ensures that a continuous thermal insulation of the building possible, even with the increasing thicknesses of facade insulation.

**For further information on this product
please call us at 0845 241 3390**

⁴⁾ Passive House Institute, Darmstadt, www.passiv.de

⁵⁾ Kronolith is a registered brand of the Kronos ecochem company

Schöck Isokorb® type KSH

on request



for the connection of free cantilevered wooden beams to reinforced concrete.



Schöck Isokorb® type QSH

on request



for the connection of supported wooden beams
to reinforced concrete.



**For further information
on this product please
call us at 0845 241 3390**

Imprint

Published by: Schöck Ltd
The Clock Tower
2 - 4 High Street
Kidlington
Oxford
OX5 2DH
Telephone: 0845 241 3390

Date of publication: October 2012

Copyright: © 2012, Schöck Ltd
The contents of this publication must not be passed on to third parties, neither in full nor in part, without the written authorisation of Schöck Ltd. All technical details, drawings etc. are protected by copyright laws.

Subject to technical changes
Date of publication: October 2012

Schöck Ltd
The Clock Tower
2 - 4 High Street
Kidlington
Oxford
OX5 2DH
Telephone: 0845 241 3390
Fax: 0845 241 3391
design@schoeck.co.uk
www.schoeck.co.uk

